



Designation: **F448 – 11 F448 – 18**

Standard Test Method for Measuring Steady-State Primary Photocurrent¹

This standard is issued under the fixed designation F448; the number immediately following the designation indicates the year of original adoption or, in the case of revision, the year of last revision. A number in parentheses indicates the year of last reapproval. A superscript epsilon (ϵ) indicates an editorial change since the last revision or reapproval.

This standard has been approved for use by agencies of the U.S. Department of Defense.

1. Scope

1.1 This test method covers the measurement of steady-state primary photocurrent, I_{pp} , generated in semiconductor devices when these devices are exposed to ionizing radiation. These procedures are intended for the measurement of photocurrents greater than 10^{-9} A·s/Gy(Si or Ge), in cases for which the relaxation time of the device being measured is less than 25 % of the pulse width of the ionizing source. The validity of these procedures for ionizing dose rates as great as 10^8 Gy(Si or Ge)/s has been established. The procedures may be used for measurements at dose rates as great as 10^{10} Gy(Si or Ge)/s; however, extra care must be taken. Above 10^8 Gy/s, the package response may dominate the device response for any device. Additional precautions are also required when measuring photocurrents of 10^{-9} A·s/Gy(Si or Ge) or lower.

1.2 Setup, calibration, and test circuit evaluation procedures are also included in this test method.

1.3 Because of the variability between device types and in the requirements of different applications, the dose rate range over which any specific test is to be conducted is not given in this test method but must be specified separately.

1.4 The values stated in SI units are to be regarded as standard. No other units of measurement are included in this standard.

1.5 *This standard does not purport to address all of the safety concerns, if any, associated with its use. It is the responsibility of the user of this standard to establish appropriate safety, health, and environmental practices and determine the applicability of regulatory limitations prior to use.*

1.6 *This international standard was developed in accordance with internationally recognized principles on standardization established in the Decision on Principles for the Development of International Standards, Guides and Recommendations issued by the World Trade Organization Technical Barriers to Trade (TBT) Committee.*

2. Referenced Documents

2.1 *ASTM Standards:*²

E668 Practice for Application of Thermoluminescence-Dosimetry (TLD) Systems for Determining Absorbed Dose in Radiation-Hardness Testing of Electronic Devices

F526 Test Method for Using Calorimeters for Total Dose Measurements in Pulsed Linear Accelerator or Flash X-ray Machines

3. Terminology

3.1 *Definitions:*

3.1.1 *fall time, n*—the time required for a signal pulse to drop from 90 to 10 % of its steady-state value.

3.1.2 *photocurrent relaxation time, n*—the time required for the radiation induced photocurrent to decrease to 1/e (0.368) of its initial value. The relaxation time depends upon the recombination-controlled photocurrent decay in the media, which is often a semiconductor. The relaxation time can depend upon the temperature and the strength of the irradiation/illumination.

3.1.3 *primary photocurrent, n*—the flow of excess charge carriers across a *p-n* junction due to ionizing radiation creating electron-hole pairs throughout the device. The charges associated with this current are only those produced in the junction depletion region and in the bulk semiconductor material approximately one diffusion length on either side of the depletion region (or to the end of the semiconductor material, whichever is shorter).

¹ This test method is under the jurisdiction of ASTM Committee F01 on Electronics and is the direct responsibility of Subcommittee F01.11 on Nuclear and Space Radiation Effects.

Current edition approved June 1, 2011; March 1, 2018. Published July 2011; April 2018. Originally approved in 1975 as F448 – 75 T. Last previous edition approved in 2005 as F448 – 99; F448 – 11. (2005). DOI: 10.1520/F0448-11; 10.1520/F0448-18.

² For referenced ASTM standards, visit the ASTM website, www.astm.org, or contact ASTM Customer Service at service@astm.org. For *Annual Book of ASTM Standards* volume information, refer to the standard's Document Summary page on the ASTM website.

3.1.4 *pulse width, n*—the time a pulse-amplitude remains above 50 % of its maximum value.

3.1.5 *rise time, n*—the time required for a signal pulse to rise from 10 to 90 % of its steady-state value.

4. Summary of Test Method

4.1 In this test method, the test device is irradiated in the primary electron beam of a linear accelerator. Both the irradiation pulse and junction current (Fig. 1) are displayed and recorded. Placement of a thin, low atomic number ($Z \leq 13$) scattering plate in the beam is recommended to improve beam uniformity; the consequences of the use of a scattering plate relating to interference from secondary electrons are described. The total dose is measured by an auxiliary dosimeter. The steady-state values of the dose rate and junction current and the relaxation time of the junction current are determined from the data trace and total dose.

4.2 In special cases, these parameters may be measured at a single dose rate under one bias condition if the test is designed to generate information for such a narrow application. The preferred approach, described in this test method, is to characterize the radiation response of a device in a way that is useful to many different applications. For this purpose, the response to pulses at a number of different dose rates is required. Because of the bias dependence of the depletion volume, it is possible that more than one bias level will be required during the photocurrent measurements.

5. Significance and Use

5.1 *PN Junction Diode*—The steady-state photocurrent of a simple *p-n* junction diode is a directly measurable quantity that can be directly related to device response over a wide range of ionizing radiation. For more complex devices the junction photocurrent may not be directly related to device response.

5.2 *Zener Diode*—In this device, the effect of the photocurrent on the Zener voltage rather than the photocurrent itself is usually most important. The device is most appropriately tested while biased in the Zener region. In testing Zener diodes or precision voltage regulators, extra precaution must be taken to make certain the photocurrent generated in the device during irradiations does not cause the voltage across the device to change during the test.

5.3 *Bipolar Transistor*—As device geometries dictate that photocurrent from the base-collector junction be much greater than current from the base-emitter junction, measurements are usually made only on the collector-base junction with emitter open; however, sometimes, to obtain data for computer-aided circuit analysis, the emitter-base junction photocurrent is also measured.

5.4 *Junction Field-Effect Device*—A proper photocurrent measurement requires that the source be shorted (dc) to the drain during measurement of the gate-channel photocurrent. In tetrode-connected devices, the two gate-channel junctions should be monitored separately.

5.5 *Insulated Gate Field-Effect Device*—In this type of device, the true photocurrent is between the substrate and the channel, source, and drain regions. A current which can generate voltage that will turn on the device may be measured by the technique used here, but it is due to induced conductivity in the gate insulator and thus is not a junction photocurrent.

6. Interferences

6.1 *Air Ionization*—A spurious component of the current measured during a photocurrent test can result from conduction through air ionized by the irradiation pulse. Although this is not likely to be a serious problem for photocurrents greater than 10^{-9} A-s/Gy (Si or Ge), the spurious contribution can easily be checked by measuring the current while irradiating the test fixture in the absence of a test device. Air ionization contributions to the observed signal are proportional to applied field, while those due to secondary emission effects (see 6.2) are not. The effects of air ionization external to the device may be minimized by coating exposed leads with a thick layer of paraffin, silicone rubber, or nonconductive enamel or by making the measurement in vacuum.

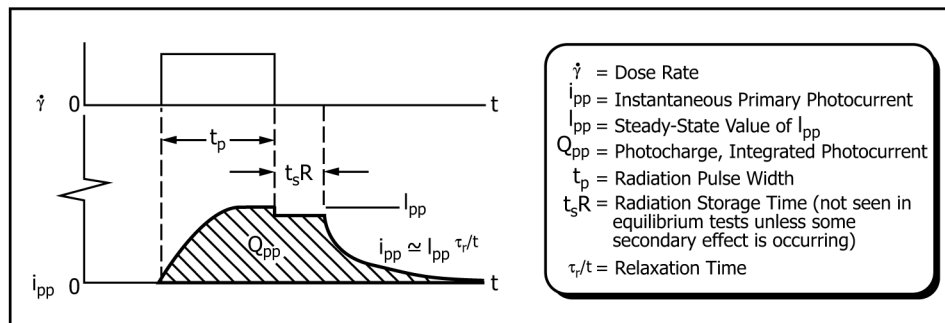

FIG. 1 Ionization Radiation Pulse and Typical Primary Photocurrent Response

6.2 *Secondary Emission*³—Another spurious component of the measured current can result from charge emission from, or charge injection into, the test device and test circuit. This may be minimized by shielding the surrounding circuitry and irradiating only the minimum area necessary to ensure irradiation of the test device. Reasonable estimates of the magnitude to be expected of current resulting from secondary-emission effects can be made based on the area of metallic target materials irradiated. Values generally range between 10^{-11} and 10^{-9} A·s/cm²·Gy, but the use of a scatter plate with an intense beam may increase this current.

6.3 *Orientation*—The effective dose to a semiconductor junction can be altered by changing the orientation of the test unit with respect to the irradiating electron beam. Most transistors and diodes may be considered “thin samples” (in terms of the range of the irradiating electrons). However, high-power devices may have mounting studs or thick-walled cases that can act to scatter the incident beam, thereby reducing the dose received by the semiconductor chip. Care must be taken in the mounting of such devices.

6.4 *Bias*—As the effective volume for the generation of photocurrent in *p-n* junction devices includes the space-charge region, I_{pp} may be dependent on applied voltage. As applied voltages approach the breakdown voltage, I_{pp} increases sharply due to avalanche multiplication. If the application of the test device is known, actual bias values should be used in the test. If the application is not known, follow the methods for checking the bias dependence given in Section 10.

6.5 *Nonlinearity*—Nonlinearities in photocurrent response result from saturation effects, injection level effects on lifetimes, and, in the case of bipolar transistors, a lateral biasing effect which introduces a component of secondary photocurrent into the primary photocurrent measurement.⁴ For these reasons, photocurrent measurements must generally be made over a wide range of dose rates.

6.6 *Electrical Noise*—Since linear accelerator facilities are inherent sources of r-f electrical noise, good noise-minimizing techniques such as single-point ground, filtered dc supply lines, etc., must be used in photocurrent measurements.

6.7 *Temperature*—Device characteristics are dependent on junction temperature; hence, the temperature of the test should be controlled. Unless otherwise agreed upon by the parties to the test, measurements will be made at room temperature ($23 \pm 5^\circ\text{C}$).

6.8 *Beam Homogeneity and Pulse-to-Pulse Repeatability*—The intensity of a beam from a linear accelerator is likely to vary across its cross section. Since the pulse-shape monitor is placed at a different location from the device under test, the measured dose rate may be different from the dose rate to which the device was exposed. The spatial distribution and intensity of the beam may also vary from pulse to pulse. The beam homogeneity and pulse-to-pulse repeatability associated with a particular linear accelerator should be established by a thorough characterization of its electron beam prior to performing a photocurrent measurement.

6.9 *Ionizing Dose*—Each pulse of the linear accelerator imparts a dose of radiation to both the device under test and the device used for dosimetry. The ionizing dose deposited in a semiconductor device can change its operating characteristics. As a result, the photocurrent that is measured after several pulses may be different from the photocurrent that is characteristic of an unirradiated device. Care should be exercised to ensure that the ionizing dose delivered to the device under test is as low as possible consistent with the requirements for a given dose rate and steady-state conditions. Generally, this is done by minimizing the number of pulses the device receives. The dose must not exceed 10 % of the failure dose for the device.

6.10 The test must be considered destructive if the photocurrent exceeds the manufacturer’s absolute limit.

6.11 *Parasitic Circuit Effects*—Circuit effects due to unintentional interaction with the circuit topology. Examples of parasitic circuit effects would be capacitance, resistance and inductance that become part of the circuit performance but are not considered active components placed within the circuit.

7. Apparatus

7.1 *Regulated dc Power Supply*, with floating output to produce the voltages required to bias the junction.

7.2 *Oscilloscopes*—Either a single dual-beam, or two single-beam oscilloscopes that have adequate bandwidth capability of both main frames and plug-ins to ensure that radiation response and peak steady-state values are accurately displayed.

7.2.1 *Oscilloscope Camera(s) and Film*, capable of recording single transient traces at a sweep rate consistent with good resolution at the pulse widths used in the test.

7.2 *Digitizers with Bandwidth, Sampling Interval, and Time-base Capabilities, Oscilloscopes*—adequate for handling the transient signals with good resolution for all pulse widths utilized in the test may be used. Hard copy printouts of the recorded signal may be a part of the capability of this apparatus. digitizing oscilloscopes capable of recording single transient traces that have adequate bandwidth capability to ensure that radiation response and peak steady-state values are accurately displayed.

³ Sawyer, J. A., and van Lint, V. A. J., “Calculations of High-Energy Secondary Electron Emission,” *Journal of Applied Physics*, JAPIA, Vol 35, No 6, June 1964, pp. 1706–1711.

⁴ Habing, D. H., and Wirth, J. L., “Anomalous Photocurrent Generation in Transistor Structures,” *IEEE Transactions on Nuclear Science*, IETNA, Vol NS-13, No 6, December 1966, pp. 86–94.

7.2.1 *Digitizers with Bandwidth, Sampling Interval, and Time-base Capabilities*, adequate for handling the transient signals with good resolution for all pulse widths utilized in the test may be used. Hard copy printouts of the recorded signal may be a part of the capability of this apparatus.

7.3 *Cabling*, to complete adequately the connection of the test circuit in the exposure area with the power supply and oscilloscopes in the data area. Any type of ungrounded wiring may be used to connect the power supply to the bias points of the test circuit; however, coaxial cables properly terminated at the oscilloscope input are required for the signal leads.

7.4 *Test Circuits*— One of the following test circuits:

7.4.1 *Resistor-Sampling Circuit (Fig. 2)*—For most tests, the configuration of Fig. 2(a) is appropriate. The resistors R_2 serve as high-frequency isolation and must be at least $20\ \Omega$. The capacitor C supplies the charge during the current transient; its value must be large enough that the decrease in voltage during a current pulse is less than 10%. Capacitor C should be paralleled by a small (approximately $0.01\ \mu\text{F}$) low-inductance capacitor to ensure that possible inductive effects of the large capacitor are offset. The resistor R_0 is to provide the proper termination (within $\pm 2\%$) for the coaxial cable used for the signal lead. When the photocurrents are large, it is necessary to use a small-value resistor, R_1 , in the configuration of Fig. 2(b) to keep the signal small so as to maintain the bias across the junction within 10% of its nominal value during the test. The response characteristics of this circuit must be adequate to ensure that the current signal is accurately displayed (see 9.4).

7.4.2 *Current Transformer Circuit (Fig. 3)*—In this circuit, R_2 and C have the same significance as in the resistor-sampling circuit, but it may be required that the signal cable monitoring the current transformer be matched to the characteristic impedance of the transformer, in which case R_0 would have this impedance (within $\pm 2\%$), which is specified by the manufacturer of the current transformer. The current transformer must have a bandwidth sufficient to ensure that the current signal is accurately displayed. Rise time must be less than 10% of the pulse width of the radiation pulse being used. The low frequency cutoff of some commercial current transformers is such that significant droop may occur for pulse widths greater than $1\ \mu\text{s}$. Do not use a transformer for which this droop is greater than 5% for the radiation pulse width used. When monitoring large photocurrents, care must be taken that the ampere-microsecond saturation of the current transformer is not exceeded.

7.5 *Irradiation Pulse-Shape Monitor*—One of the following to develop a signal proportional to the dose rate delivered to the test device:

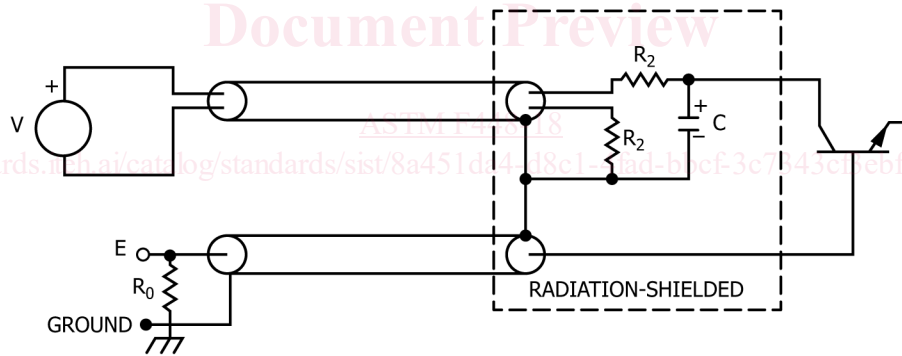

(a) For General Use

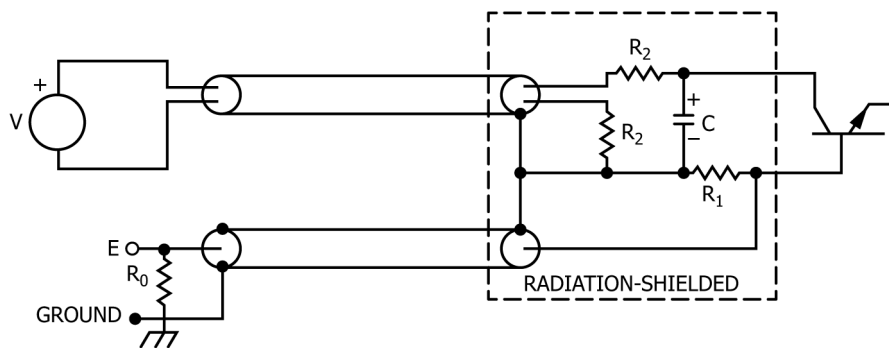

(b) For Large Photocurrents

FIG. 2 Resistor-Sampling Test Circuits