



Designation: **D5764 – 97a (Reapproved 2013) D5764 – 97a (Reapproved 2018)**

Standard Test Method for Evaluating Dowel-Bearing Strength of Wood and Wood- Based Products¹

This standard is issued under the fixed designation D5764; the number immediately following the designation indicates the year of original adoption or, in the case of revision, the year of last revision. A number in parentheses indicates the year of last reapproval. A superscript epsilon (ϵ) indicates an editorial change since the last revision or reapproval.

1. Scope

1.1 This test method provides the basic procedure for evaluating dowel-bearing strength of wood and wood-based products. The bearing test results are used to determine the static load resistance and deformation characteristics of connections in wood and wood-base products resulting from the application of a load transmitted by a fastener inserted into a predrilled hole, or driven without drilling. Methods are given for preparing specimens with predrilled holes larger than the fastener diameter and specimens with holes produced by inserting fasteners in holes smaller than the fastener diameter. The methods apply to fasteners such as dowels, bolts, nails, spikes, drift pins, screws, lag screws, and staples.

1.2 This test method also provides the basis for determining the compression behavior of wood products beneath a laterally loaded fastener where the thickness of the product and the diameter of the fastener are such that minimal bending of the fastener occurs during testing.

1.3 *This standard does not purport to address all of the safety concerns, if any, associated with its use. It is the responsibility of the user of this standard to establish appropriate safety, health, and environmental practices and determine the applicability of regulatory limitations prior to use.*

1.4 *This international standard was developed in accordance with internationally recognized principles on standardization established in the Decision on Principles for the Development of International Standards, Guides and Recommendations issued by the World Trade Organization Technical Barriers to Trade (TBT) Committee.*

2. Referenced Documents

2.1 *ASTM Standards:*²

D143 Test Methods for Small Clear Specimens of Timber

D2395 Test Methods for Density and Specific Gravity (Relative Density) of Wood and Wood-Based Materials

D2915 Practice for Sampling and Data-Analysis for Structural Wood and Wood-Based Products

D4442 Test Methods for Direct Moisture Content Measurement of Wood and Wood-Based Materials

E4 Practices for Force Verification of Testing Machines

3. Terminology

3.1 *Definitions:*

3.1.1 *dowel-bearing behavior*—the load-deformation behavior of wood or wood-base products laterally loaded by a fastener where the fastener does not bend during loading.

3.1.2 *dowel-bearing strength*—yield load obtained from the load-deformation curve of a dowel-bearing test divided by the dowel diameter and specimen thickness.

4. Summary of Test Method

4.1 Specimens consisting of a single rectangular parallelepiped member with a fastener hole perpendicular to the faces of the member are evaluated for the resistance to embedding the fastener into the fastener hole, so as not to bend the fastener. Tests are conducted on a testing machine at a uniform deformation rate, while loads and deformation are measured at various intervals. Supplementary physical properties of the wood or wood-base member are also determined.

¹ This test method is under the jurisdiction of ASTM Committee D07 on Wood and is the direct responsibility of Subcommittee D07.05 on Wood Assemblies. Current edition approved April 1, 2013; March 1, 2018. Published April 2013; April 2018. Originally approved in 1995. Last previous edition approved in 2007; 2013 as D5764 – 97a (2007); (2013). DOI: 10.1520/D5764-97AR13-10.1520/D5764-97AR18.

² For referenced ASTM standards, visit the ASTM website, www.astm.org, or contact ASTM Customer Service at service@astm.org. For *Annual Book of ASTM Standards* volume information, refer to the standard's Document Summary page on the ASTM website.

5. Significance and Use

5.1 The localized crushing behavior of wood or wood-base products beneath a fastener where the fastener does not bend provides a material property that is used in theoretical models for connections where crushing or fastener bending, or both, occur. These theoretical models are used to establish design values for wood and wood-base connections. The tests are appropriate when studying the effects of such variables as fastener diameter, fastener hole size, moisture content, specific gravity, and grain direction on the dowel-bearing strength.

6. Apparatus

6.1 *Testing Machine*—Any suitable testing machine capable of operation at a constant rate of motion of its movable head and having an accuracy of $\pm 1\%$ when calibrated in accordance with Practices E4.

6.2 *Deformation Gage*—A deformation-measuring device, with a least reading of 0.001 in. (0.025 mm) for measuring the movement of the fastener into the wood or wood-base specimen.

7. Sampling

7.1 Sampling shall provide for selection of representative test specimens which are appropriate to the objectives of the testing program.

7.2 Sample size shall be estimated using procedures in Practice D2915.

NOTE 1—The precision required, the manner of sampling, and the number of tests will depend upon the specific test objectives. General experience indicates that the coefficient of variation from embedment tests ranges from 15 to 30 %.

8. Specimens

8.1 Wood members shall be selected, and the dowel positioned in such a way that the results are not affected by knots, cross grain, or other natural or manufacturing characteristics, unless the objective of the study is to determine the effect of such variables. Frequently, this will necessitate selecting members which are essentially clear and straight grained. For wood-based products, specimens shall be selected with regard to manufactured characteristics.

8.2 *Specimen Dimensions:*

8.2.1 Specimens shall consist of a rectangular parallelepiped member with half a dowel hole across one face (see Fig. 1).

8.2.2 For solid wood and wood composites, minimum dimensions shall be made large enough so splitting does not occur during fabrication and not less than as follows (see Fig. 1):

Thickness	≧	the smaller of 1½ in. (38 mm), or 2 dowel diameters
Width	≧	the larger of 2 in. (50 mm) or 4 dowel diameters
Length	≧	the larger of 2 in. (50 mm) or 4 dowel diameters

NOTE 2—For driven dowels in species that tend to split, larger than minimum dimensions are recommended to prevent splitting during specimen preparation and testing.

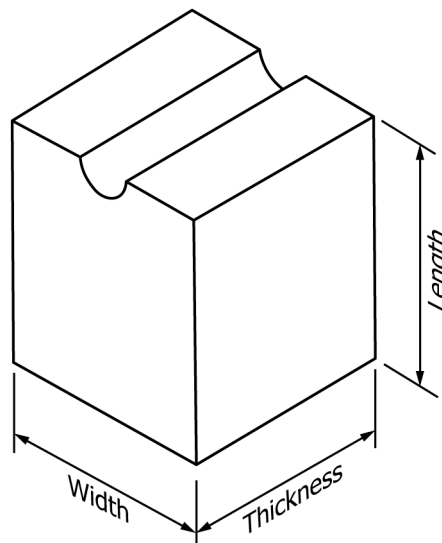

NOTE 1—Half of the fastener hole is produced by drilling oversized hole or by the method shown in Fig. 4.

FIG. 1 Specimen Configuration

8.2.2.1 For specimens that tend to split before the completion of the test, a full hole test configuration is allowed in Fig. 2. Minimum dimensions shall be made large enough so splitting does not occur during fabrication and not less than as follows (see Fig. 3):

Thickness	≧	the smaller of 1½ in. (38 mm) or 2 dowel diameters
Width	≧	the larger of 2 in. (50 mm) or 4 dowel diameters
Length:		
Loaded End	≧	the larger of 2 in. (50 mm) or 4 dowel diameters
Unloaded End	≧	the larger of 1 in. (50 mm) or 2 dowel diameters

8.2.3 For wood-base panel products, the minimum thickness shall be the thickness of the panel. Minimum width and length shall be the same as for solid wood.

8.2.4 Fastener holes for fasteners that are installed in drilled holes that are equal to or greater than the fastener diameter shall be typical of those used in service. Drill the hole perpendicular and through the specimen and into an adjacent wood block to minimize splitting of the face where the drill bit exits. Then saw the specimen through the hole to produce a specimen with a half hole. For bolts, the hole shall be ¼ in. (1.6 mm) larger than the bolt diameter. If other hole sizes are specified for the fastener, specimens shall have the specified hole size.

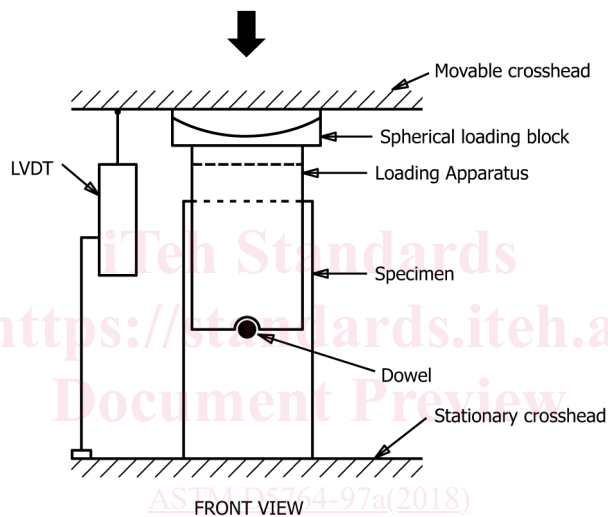

<https://standards.iteh.ai/catalog/standards/sist/4f4de548-5784-436a-9eae-5874408e0d3f/astm-d5764-97a2018>

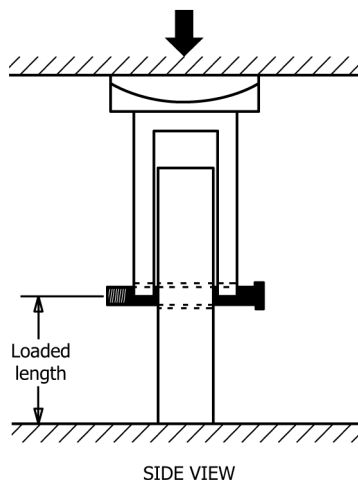

FIG. 2 Schematic of Testing Setup—Full Hole