



Designation: D5093 – 15^{ε1}

Standard Test Method for Field Measurement of Infiltration Rate Using Double-Ring Infiltrometer with Sealed-Inner Ring¹

This standard is issued under the fixed designation D5093; the number immediately following the designation indicates the year of original adoption or, in the case of revision, the year of last revision. A number in parentheses indicates the year of last reapproval. A superscript epsilon (ϵ) indicates an editorial change since the last revision or reapproval.

^{ε1} NOTE—Editorially updated units of measurement statement in April 2018.

1. Scope

1.1 This test method describes a procedure for measuring the infiltration rate of water through in-place soils using a double-ring infiltrometer with a sealed inner ring.

1.2 This test method is useful for soils with infiltration rates in the range of 1×10^{-5} cm/s to 1×10^{-8} cm/s. When infiltration rates $\geq 1 \times 10^{-5}$ cm/s are to be measured Test Method **D3385** shall be used.

1.3 All observed and calculated values shall conform to the guide for significant digits and rounding established in Practice **D6026**.

1.3.1 The method used to specify how data are collected, calculated, or recorded in this standard is not directly related to the accuracy to which the data can be applied in design or other uses, or both. How one applies the results obtained using this standard is beyond its scope.

1.4 This test method provides a direct measurement of infiltration rate, not hydraulic conductivity. Although the units of infiltration rate and hydraulic conductivity are similar, there is a distinct difference between these two quantities. They cannot be directly related unless the hydraulic boundary conditions, such as hydraulic gradient and the extent of lateral flow of water are known or can be reliably estimated.

1.5 This test method can be used for natural soil deposits, recompacted soil layers, and amended soils such as soil bentonite and soil lime mixtures.

1.6 The values stated in SI units are to be regarded as standard. The values given in parentheses after SI units are provided for information only and are not considered standard.

1.7 *This standard does not purport to address all of the safety concerns, if any, associated with its use. It is the responsibility of the user of this standard to establish appropriate*

appropriate safety, health, and environmental practices and determine the applicability of regulatory limitations prior to use.

1.8 *This international standard was developed in accordance with internationally recognized principles on standardization established in the Decision on Principles for the Development of International Standards, Guides and Recommendations issued by the World Trade Organization Technical Barriers to Trade (TBT) Committee.*

2. Referenced Documents

2.1 *ASTM Standards:*²

D653 Terminology Relating to Soil, Rock, and Contained Fluids

D3385 Test Method for Infiltration Rate of Soils in Field Using Double-Ring Infiltrometer

D3740 Practice for Minimum Requirements for Agencies Engaged in Testing and/or Inspection of Soil and Rock as Used in Engineering Design and Construction

D6026 Practice for Using Significant Digits in Geotechnical Data

3. Terminology

3.1 *Definitions:*

3.1.1 For common definitions of technical terms in this standard, refer to Terminology **D653**.

3.2 *Definitions of Terms Specific to This Standard:*

3.2.1 *infiltration*—downward entry of liquid into a porous body.

3.2.2 *infiltration rate, I*—quantity of liquid entering a porous material (m^3) per unit area (m^2) per unit time (s), expressed in units of m/s.

3.2.3 *infiltrometer*—a device used to pond liquid on a porous body and to allow for the measurement of the rate at which liquid enters the porous body.

¹ This test method is under the jurisdiction of ASTM Committee **D18** on Soil and Rock and is the direct responsibility of Subcommittee **D18.04** on Hydrologic Properties and Hydraulic Barriers.

Current edition approved June 1, 2015. Published July 2015. Originally approved in 1990. Last previous edition approved in 2008 as D5093 – 02(2008). DOI: 10.1520/D5093-15E01.

² For referenced ASTM standards, visit the ASTM website, www.astm.org, or contact ASTM Customer Service at service@astm.org. For *Annual Book of ASTM Standards* volume information, refer to the standard's Document Summary page on the ASTM website.

4. Summary of Test Method

4.1 The infiltration rate of water through soil is measured using a double-ring infiltrometer with a sealed or covered inner ring (Fig. 1). The infiltrometer consists of an open outer and a sealed inner ring. The rings are embedded and sealed in trenches excavated in the soil. Both rings are filled with water such that the inner ring is submerged.

4.2 The rate of flow is measured by connecting a flexible bag filled with a known weight of water to a port on the inner ring. As water infiltrates into the ground from the inner ring, an equal amount of water flows into the inner ring from the flexible bag. After a known interval of time, the flexible bag is removed and weighed. The weight loss, converted to a volume, is equal to the amount of water that has infiltrated into the ground. An infiltration rate is then determined from this volume of water, the area of the inner ring, and the interval of time. This process is repeated and a plot of infiltration rate versus time is constructed. The test is continued until the infiltration rate becomes steady or until it becomes equal to or less than a specified value.

5. Significance and Use

5.1 This test method provides a means to measure low infiltration rates associated with fine-grained, clayey soils, and are in the range of 1×10^{-5} cm/s to 1×10^{-8} cm/s.

5.2 This test method is particularly useful for measuring liquid flow through soil moisture barriers such as compacted clay liner or covers used at waste disposal facilities, for canal and reservoir liners, for seepage blankets, and for amended soil liners such as those used for retention ponds or storage tanks.

5.3 The purpose of the sealed inner ring is to: (1) provide a means to measure the actual amount of flow rather than a drop in water elevation which is the flow measurement procedure used in Test Method D3385 and (2) to eliminate evaporation losses.

5.4 The purpose of the outer ring is to promote one-dimensional, vertical flow beneath the inner ring. The use of large diameter rings and large depths of embedments helps to ensure that flow is essentially one-dimensional.

5.5 This test method provides a means to measure infiltration rate over a relatively large area of soil. Tests on large volumes of soil can be more representative than tests on small volumes of soil.

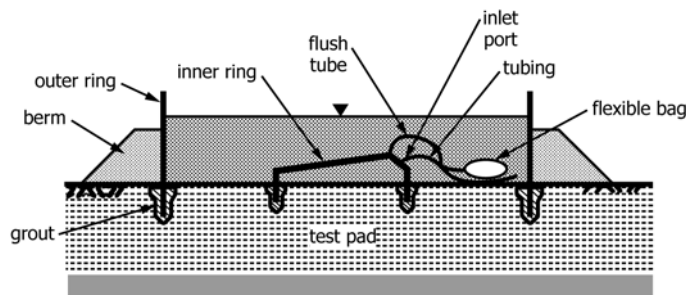

FIG. 1 Schematic Of A Double-Ring Infiltrimeter With A Sealed Inner Ring

5.6 The data obtained from this test method are most useful when the soil layer being tested has a uniform distribution of pore space, and when the density and degree of saturation and the hydraulic conductivity of the material underlying the soil layer are known.

5.7 Changes in water temperature can introduce significant error in the volume change measurements. Temperature changes will cause water to flow in or out of the inner ring due to expansion or contraction of the inner ring and the water contained within the inner ring.

5.8 The problem of temperature changes can be minimized by insulating the rings, by allowing enough flow to occur so that the amount of flow resulting from a temperature change is not significant compared to that due to infiltration, or by connecting and disconnecting the bag from the inner ring when the water in the inner ring is at the same temperature.

5.9 If the soil being tested will later be subjected to increased overburden stress, then the infiltration rate can be expected to decrease as the overburden stress increases. Laboratory hydraulic conductivity tests are recommended for studies of the influence of level of stress on the hydraulic properties of the soil.

NOTE 1—The quality of the result produced by this standard depends on the competence of the personnel performing it and the suitability of the equipment and facilities being used. Agencies that meet the criteria of Practice D3740 are generally considered capable of competent and objective testing, sampling, inspection, etc. Users of this standard are cautioned that compliance with Practice D3740 does not in itself ensure reliable results. Reliable results depend on many factors; Practice D3740 provides a means of evaluating some of those factors

6. Apparatus

6.1 *Infiltrimeter Rings*—The rings shall be constructed of a stiff, corrosion-resistant material such as metal, plastic, or fiberglass. The shape of the rings can be circular or square. However, square rings are recommended because it is easier to excavate straight trenches in the soil. The rings can be of any size provided: (1) the minimum width or diameter of the inner ring is 610 mm (24 in.); and (2) a minimum distance of 610 mm (24 in.) is maintained between the inner and outer ring. The following is a description of a set of rings that can be constructed from commonly available materials, incorporates the requirements described above, and has worked well in the field.

6.1.1 *Outer Ring*—A square ring (Fig. 2) comprised of four

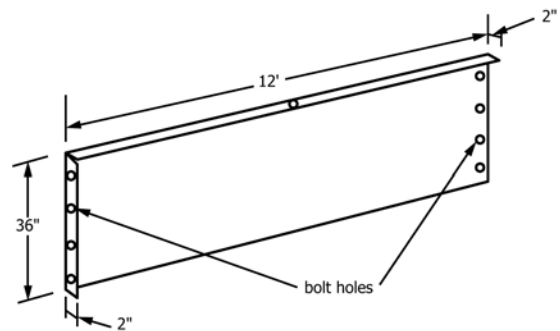
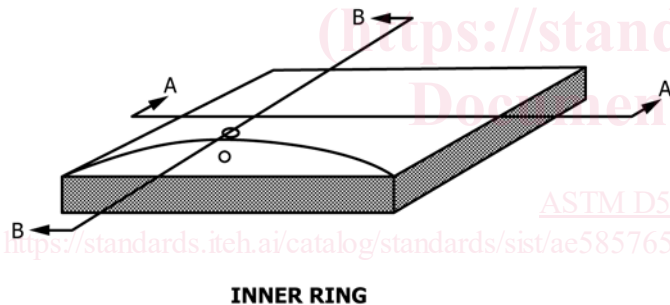

FIG. 2 Panel For Outer Ring

sheets of aluminum approximately 3.6 m by 0.9 m by 2 mm (12 ft by 3 ft by 0.080 in.). The top edge of the aluminum sheet is bent 90° in order to provide rigidity. A hole is provided in the center of the top edge. One edge of each sheet is bent 90°. Holes are drilled along each side edge so that the sheets can be bolted at the corners. A flat rubber, polyethylene, or neoprene gasket provides a seal at each corner. A wire cable approximately 15 m (49 ft) long with a clamp may be needed to tie the top edges together.

6.1.2 *Inner Ring*—A square ring (Fig. 3), 1.52 m (5 ft) on a side, made of fiberglass provided with two ports. The top is shaped in such a way as to vent air from the ring as it is filled. A port is provided at the highest point so that any air that accumulates in the ring during the test can be flushed out. One port must be located at the top of the ring. The other port must be located beneath the top port. A 150 mm (6 in.) skirt, that is embedded into the soil, is provided along the edge of the ring. Barbed fittings that accept flexible tubing are attached to the ports. Handles are provided at each corner of the inner ring.

6.2 *Flexible Bag*—Two clear flexible bags with a capacity of 1000 to 3000 mL. Intravenous bags available from medical supply stores work well. A means for attaching a shut-off valve to the bag shall be provided. The shut-off valve shall be provided with a barbed fitting that will connect to the inlet tube on the inner ring.



INNER RING

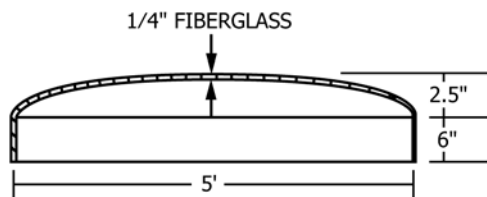

SECTION A-A

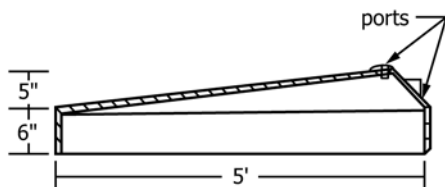

SECTION B-B

FIG. 3 Inner Ring

6.3 *Tubing*—Clear, flexible tubing approximately 4.5 m (15 ft) long with a minimum ID of 6 mm (1/4 in.)

6.4 *Scissors or Knife*.

6.5 *Excavation Tools*.

6.5.1 *Mason's Hammer*—Hammer with a blade approximately 120 mm (5 in.) long and 40 mm (1.5 in.) wide.

6.5.2 *Trenching Machine*—Capable of excavating a trench with a maximum width of 150 mm (6 in.) and a depth of 460 mm (18 in.).

6.5.3 *Chain Saw*—(Optional—see Note 2) Equipped with a carbide-tipped chain and bar.

6.5.4 *Hand Shovel*—Garden type.

6.6 *Levels*—A surveyor's level and rod and a carpenter's level.

6.7 *Buckets*—Five buckets with a capacity of approximately 20 L (5 gal).

6.8 *Blocks*—Cinder blocks to serve as a platform for the flexible bag.

6.9 *Cover*—An opaque cover to place on top of the outer ring. The cover can be a tarp or plywood supported by wooden beams.

6.10 *Grout*—A bentonite grout (bentonite and water) for filling the trenches and sealing the rings in place.

6.11 *Mixing Equipment*—A large (four bag) grout mixer for mixing the bentonite grout.

6.12 *Trowel*.

6.13 *Thermometer*—Readable to 0.5 °C with a range of 0 to 50 °C.

6.14 *Scale*—Capacity of 4000 g and a readability of 1 g.

6.15 *Watch*—Readable to 1 s.

6.16 *Water Supply*—Preferably water of the same quality as that involved in the problem being examined. Approximately 5600 L (1400 gal) are needed for this test.

6.17 *Splash Guard*—Plywood, rubber sheet, or burlap 600 by 600 mm (2 by 2 ft).

7. Test Site

7.1 The test requires an area of approximately 7.3 by 7.3 m (24 by 24 ft).

7.2 The slope to the test area should be no greater than approximately 3 %.

7.3 The test may be set up in a pit if infiltration rates are desired at depth rather than at the surface.

7.4 The test area shall be covered with a sheet of plastic to keep the surface from drying.

7.5 Representative samples of the soil to be tested shall be taken before and after the test to determine its moisture content, density, and specific gravity. The thickness of the layer being tested shall be determined as well as the approximate hydraulic conductivity of the layer beneath it.