



Designation: D8161 – 17

# Standard Test Method for Impact Resistance of Thermoplastic Pavement Marking Materials over a Highway Substrate by Means of a Striker Impacted by a Falling Weight<sup>1</sup>

This standard is issued under the fixed designation D8161; the number immediately following the designation indicates the year of original adoption or, in the case of revision, the year of last revision. A number in parentheses indicates the year of last reapproval. A superscript epsilon ( $\epsilon$ ) indicates an editorial change since the last revision or reapproval.

## 1. Scope

1.1 This test method covers the sample preparation over a road-type substrate and test methodology of thermoplastic pavement marking materials similar to the “Gardner Impact” method as listed in Test Method [D5420](#).

1.2 The values stated in inch-pound units are to be regarded as standard. The values given in parentheses are mathematical conversions to SI units that are provided for information only and are not considered standard.

1.3 *This standard does not purport to address all of the safety concerns, if any, associated with its use. It is the responsibility of the user of this standard to establish appropriate safety, health, and environmental practices and determine the applicability of regulatory limitations prior to use.*

1.4 *This international standard was developed in accordance with internationally recognized principles on standardization established in the Decision on Principles for the Development of International Standards, Guides and Recommendations issued by the World Trade Organization Technical Barriers to Trade (TBT) Committee.*

## 2. Referenced Documents

### 2.1 ASTM Standards:<sup>2</sup>

[D883 Terminology Relating to Plastics](#)

[D2794 Test Method for Resistance of Organic Coatings to the Effects of Rapid Deformation \(Impact\)](#)

[D4796 Test Method for Bond Strength of Thermoplastic Pavement Marking Materials](#)

[D5420 Test Method for Impact Resistance of Flat, Rigid Plastic Specimen by Means of a Striker Impacted by a Falling Weight \(Gardner Impact\)](#)

[D5628 Test Method for Impact Resistance of Flat, Rigid Plastic Specimens by Means of a Falling Dart \(Tup or Falling Mass\)](#)

[D7307 Practice for Sampling of Thermoplastic Traffic Marking Materials](#)

[D7308 Practice for Sample Preparation of Thermoplastic Pavement Marking Materials](#)

[E177 Practice for Use of the Terms Precision and Bias in ASTM Test Methods](#)

[E284 Terminology of Appearance](#)

[E691 Practice for Conducting an Interlaboratory Study to Determine the Precision of a Test Method](#)

## 3. Terminology

### 3.1 Definitions:

3.1.1 The terms and definitions in Terminology [D883](#) and [E284](#) apply to this method.

### 3.2 Definitions of Terms Specific to This Standard:

3.2.1 *failure (of test specimen), n*—the presence of any crack or split created by the impact of the falling weight that can be seen by the naked eye under normal laboratory lighting conditions.

3.2.2 *Falling Weight (Gardner) Impact Tester, n*—impact tester designed as described in Test Method [D5420](#).

3.2.3 *thermoplastic pavement marking, n*—a highly filled 100 % total solids highway marking system that when heated to a molten state can be extruded or sprayed onto a road surface and when cooled forms a solid durable delineator or marking.

## 4. Summary of Test Method

4.1 In this test method, a weight falls through a guide tube and impacts a striker resting on top of a supported specimen. This test method is similar to Test Methods [D5420](#) and [D2794](#) except the impact occurs on thermoplastic pavement marking material applied over a solid road-type substrate with minimal deformation.

4.2 The test result is typically pass/fail, however maximum impact to cause material failure can be determined as shown by cracking, chipping, delaminating, etc.

<sup>1</sup> This test method is under the jurisdiction of ASTM Committee [D01](#) on Paint and Related Coatings, Materials, and Applications and is the direct responsibility of Subcommittee [D01.44](#) on Traffic Coatings.

Current edition approved Dec. 1, 2017. Published April 2018. DOI: 10.1520/D8161-17.

<sup>2</sup> For referenced ASTM standards, visit the ASTM website, www.astm.org, or contact ASTM Customer Service at service@astm.org. For *Annual Book of ASTM Standards* volume information, refer to the standard's Document Summary page on the ASTM website.

## 5. Significance and Use

5.1 The significance of this test is to determine the thermo-plastic pavement marking material's resistance to impact over a simulated pavement substrate, under laboratory conditions, and is expressed as pass/fail or numerically. The test result can be used as a quality test or to differentiate marking materials.

5.2 Anyone attempting to perform this test should initially review Test Methods D5420 and D2794, specifically the equipment setup.

5.3 Sample preparation and equipment set-up should be followed precisely to minimize variability in the test result.

## 6. Interferences

6.1 Falling-weight-impact test results are dependent on the geometry of the falling weight, striker, and the support. Thus, use impact tests only to obtain relative rankings of materials. Impact values cannot be considered absolute unless the geometry of the test equipment and specimen conform to the end-use requirement. Data obtained with different geometries, cannot, in general, be compared directly with each other

6.2 Since this method is based on the impact of a material on a non-deformable substrate, the failure mode can come in many different forms. This method may not cover the type of deformation seen on some type of products. In this instance, a determination of whether an impact causes a passing or a failing deformation will then need to be determined by the buyer and the seller.

6.3 Impact properties of thermoplastic pavement marking materials can be very sensitive to temperature. This test can be carried out at any reasonable temperature and humidity, thus representing actual-use environments. However, this test method as written is intended primarily for rating materials under specific impact conditions and at  $75 \pm 2^\circ\text{F}$  ( $24 \pm 1^\circ\text{C}$ ).

6.4 It is possible that the apparatus used in this test method will not have sufficient energy available to cause failure of some specimens under the conditions of this procedure.

## 7. Apparatus

7.1 The basics of the apparatus are shown in Fig. 1 minus the specimen support plate and support anvil. More detailed information can be found in the Apparatus section of Test Methods D5420 and D2794.

7.1.1 The difference being that the test sample on the road substrate is placed under the striker, and on the base of the apparatus instead of on the specimen support anvil as shown in Fig. 2.

7.2 Although there are many sizes and shapes of strikers for this method, we are recommending that only a  $0.625 \pm 0.004$  in. ( $15.86 \pm 0.10$  mm) striker be used.

7.3 Although many weight loads can be used, a 2 lb (0.9 kg) weight is the most common and will be the only type addressed within this method.

## 8. Reagents and Materials

8.1 *Four (4) in. Wide Drawdown Bar*, capable of drawing down a 0.125 in. thick film of thermoplastic pavement mark-

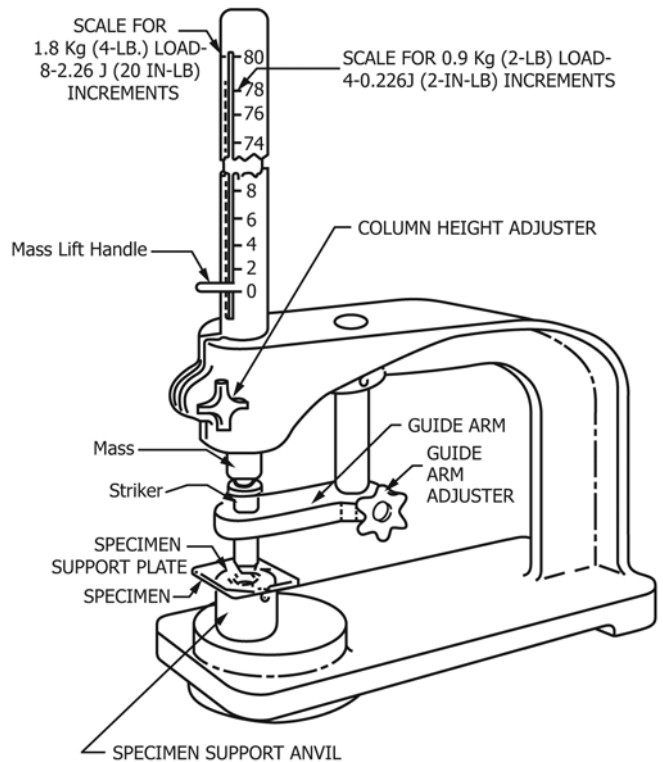

FIG. 1 Impact Tester

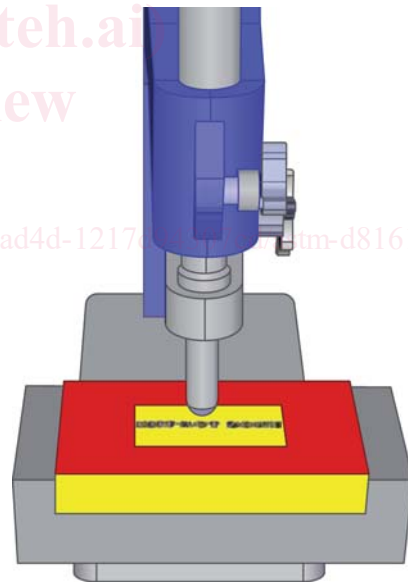

FIG. 2 Specimen Support Anvil

ing. Other width drawdown bars and drawdown gaps can be used but this is the most common for the thermoplastic pavement marking industry (Fig. 3).

8.2 *Concrete Brick*, with a minimum of 3000 psi compression strength or substrate of choice.

8.3 *Asphalt Samples*, cored from a road surface or made to a specific formulation and compressed in a Marshall testing device, then sawed in half. The top half of these types of



FIG. 3 Drawdown Bar



FIG. 5 Warmed Drawdown Bar

samples can be used to simulate fresh asphalt and the cut side worn or aged asphalt surfaces (Fig. 4).

8.4 Any other type of road surface or road surface covered with an overlay or road marking can be used.

### 9. Hazards

9.1 Impact testing of any type can cause flying debris, so safety glasses, at a minimum, should be worn at all times. Hands are best kept away from the falling weight and impact zone. The testing device and substrate should be on a stable level surface at all times.

### 10. Sampling, Test Specimens, and Test Units

10.1 Sampling thermoplastic road marking material should be performed by following Practice D7307.

10.2 The initial melting of the thermoplastic pavement marking materials should be performed in accordance with Practice D7308.

10.3 Once the thermoplastic pavement marking material has reached the appropriate processing temperature, then it can be drawn over the substrate using a warmed drawdown bar (Fig. 5).

### 11. Preparation of Apparatus

11.1 In order to minimize the energy absorption, compression and deflection of the support, affix the tester to a dense, solid block. Place this block or base at a height suitable for ease of operation. It is not necessary to bolt blocks or bases over



FIG. 4 Asphalt Samples

400 lb to the floor. Alternatively, affix testers directly to the floor. (**Warning**—Use of rubber mats either directly under the tester or supporting apparatus is prohibited.)

11.2 Bolt supporting bases, or tables, lighter than 400 lb to a concrete floor. For each different material tested, make comparisons between mean failure energy data generated using this support, and one where the tester is fixed directly to the concrete floor. If mean failure energy differences between two types of supports are found to be statistically non-significant, use of the lighter support shall be allowed.

### 12. Calibration and Standardization

12.1 The striker diameter and striking end should be checked periodically to make sure that they have not changed or been damaged from impacts.

12.2 The load's weight and strike diameter should be checked to verify that it is within tolerances.

### 13. Conditioning

13.1 Any thermoplastic pavement marking material applied to a substrate, substrate and impact device should be allowed to come to  $75 \pm 2^\circ\text{F}$  ( $24 \pm 1^\circ\text{C}$ ) and 30 to 50 % RH before testing.

13.1.1 If a different temperature/humidity is required for testing, then that temperature/humidity should be stable for the test material, the substrate and the impact device before testing.

13.1.2 Some manufacturers may require that the test material not be tested for 24 h or longer after sample prep.

### 14. Procedure

14.1 *Method A – Pass/Fail Testing*—(where the load is raised to the same height for each impact).

14.1.1 Install the striker having the head diameter specified or agreed upon (Fig. 6).

14.2 Place the test sample in the apparatus with the thermoplastic pavement marking coated side facing up. Stabilize and level the thermoplastic pavement marking materials coated substrate directly under the striker. The highway substrate