



Standard Specification for Plastic Insert Fittings Utilizing a Copper Crimp Ring for SDR9 Cross-linked Polyethylene (PEX) Tubing and SDR9 Polyethylene of Raised Temperature (PE-RT) Tubing¹

This standard is issued under the fixed designation F2159; the number immediately following the designation indicates the year of original adoption or, in the case of revision, the year of last revision. A number in parentheses indicates the year of last reapproval. A superscript epsilon (ϵ) indicates an editorial change since the last revision or reapproval.

1. Scope*

1.1 This specification establishes requirements for sulfone plastic insert fittings and copper crimp rings for four sizes ($\frac{3}{8}$, $\frac{1}{2}$, and $\frac{3}{4}$ and 1) of cross-linked polyethylene (PEX) tubing that meet the requirements for Specification F876 and polyethylene of raised temperature (PE-RT) tubing that meet the requirements of Specifications F2623 and F2769. These fittings are intended for use in 100 psi (690 kPa) cold- and hot-water distribution systems operating at temperatures up to and including 180°F (82°C); 180°F (82°C). Included are the requirements for material, molded part properties, performance, workmanship, dimensions, and markings to be used on the fittings and rings.

1.2 *Units*—The values stated in inch-pound units are to be regarded as standard. The values given in parentheses are mathematical conversions to SI units that are provided for information only and are not considered standard.

1.3 The following is an index of the appendix in this specification:

GO/NO-GO Crimp Gauges

Appendix X1

1.4 The following precautionary caveat pertains only to the test method portions, Sections 11 and 12, of this specification. *This standard does not purport to address all of the safety concerns, if any, associated with its use. It is the responsibility of the user of this standard to establish appropriate safety, health, and environmental practices and determine the applicability of regulatory requirements/limitations prior to use.*

1.5 *This international standard was developed in accordance with internationally recognized principles on standardization established in the Decision on Principles for the Development of International Standards, Guides and Recommendations issued by the World Trade Organization Technical Barriers to Trade (TBT) Committee.*

2. Referenced Documents

2.1 *ASTM Standards:*²

D618 Practice for Conditioning Plastics for Testing

D1598 Test Method for Time-to-Failure of Plastic Pipe Under Constant Internal Pressure

D1599 Test Method for Resistance to Short-Time Hydraulic Pressure of Plastic Pipe, Tubing, and Fittings

D1600 Terminology for Abbreviated Terms Relating to Plastics

D2122 Test Method for Determining Dimensions of Thermoplastic Pipe and Fittings

D6394 Specification for Sulfone Plastics (SP)

F412 Terminology Relating to Plastic Piping Systems

F876 Specification for Crosslinked Polyethylene (PEX) Tubing

F1498 Specification for Taper Pipe Threads 60° for Thermoplastic Pipe and Fittings

F1807 Specification for Metal Insert Fittings Utilizing a Copper Crimp Ring for SDR9 Cross-linked Polyethylene (PEX) Tubing and SDR9 Polyethylene of Raised Temperature (PE-RT) Tubing

F2623 Specification for Polyethylene of Raised Temperature (PE-RT) SDR 9 Tubing

F2769 Specification for Polyethylene of Raised Temperature (PE-RT) Plastic Hot and Cold-Water Tubing and Distribution Systems

¹ This specification is under the jurisdiction of ASTM Committee F17 on Plastic Piping Systems and is the direct responsibility of Subcommittee F17.10 on Fittings. Current edition approved Aug. 1, 2014/April 1, 2018. Published September 2014/April 2018. Originally approved 2001. Last previous edition approved in 2014 as F2159-14-14. DOI: 10.1520/F2159-14.

² For referenced ASTM standards, visit the ASTM website, www.astm.org, or contact ASTM Customer Service at service@astm.org. For *Annual Book of ASTM Standards* volume information, refer to the standard's Document Summary page on the ASTM website.

*A Summary of Changes section appears at the end of this standard

2.2 *ASME Standard:*

B 1.20.1 Pipe Threads General Purpose Inch³

2.3 *NSF International Standard:*

ANSI/NSF Standard No. 14 for Plastic Piping Components and Related Materials⁴

ANSI/NSF Standard No. 61 for Drinking Water System Components-Health Effects⁴

3. Terminology

3.1 *Definitions*—Definitions are in accordance with Terminology **F412** and abbreviations are in accordance with Terminology **D1600**, unless otherwise indicated.

4. Classification

4.1 This specification governs one class of fittings and copper crimp rings suitable for use with nominal size $\frac{3}{8}$, $\frac{1}{2}$, $\frac{3}{4}$ and 1 size PEX tubing that meets the requirements of ASTM Specifications **F876** and PE-RT tubing that meets the requirements of Specifications **F2623** and **F2769**.

5. Materials and Manufacture

5.1 *Material*—Fittings shall be molded from sulfone plastic (SP) as specified in Specification **D6394**. The material shall be unreinforced polysulfone (group 01, class 1, grades 1 or 2) or polyphenylsulfone (group 03, class 1, grade 1 or 2) or unreinforced polyphenylsulfone/polysulfone blends (group 04, Class 1, grade 2) or reworked plastic in accordance with **5.1.1**.

NOTE 1—Since fittings specified by this standard will be used in hot-and-cold water plumbing systems, a material used to manufacture fittings in accordance with this specification must demonstrate qualities consistent with that application in addition to the performance requirements of this specification. Those qualifying characteristics include, but are not limited to, an established hydrostatic design basis (HDB) or stress design basis (SDB) in accordance with PPI TR-3 or similar rating and a demonstration of resistance to the long-term effects of those chemicals normally found in potable water at the maximum temperature stated in this specification.

5.1.1 *Rework Material*—Clean rework material of the same commercial designation, generated from the manufacturer's own production may be used by the same manufacturer, provided the fittings meet all of the requirements of this specification. Reworked material shall not be introduced at a ratio exceeding 25 %.

5.2 *Potable Water Requirements*—Products intended for the transport of potable water shall be evaluated, tested and certified for conformance with ANSI/NSF Standard No. 61 or the health effects portion of ANSI/NSF Standard No. 14 by an acceptable certifying organization when required by the regulatory authority having jurisdiction.

5.3 *Crimp Rings*—Crimp rings shall be manufactured and marked in accordance with the requirements of Specification **F1807**.

6. Molded Part Properties

6.1 *Insert Crush*—The fitting insert shall not crack, split, or shatter when tested in accordance with **12.1**.

6.2 *Splay*—The molded part shall be free of visible splay excepting some slight blushing at the gate location.

7. Performance Requirements

7.1 *General*—All performance tests shall be performed on assemblies of fittings, crimp rings, and PEX tubing or PE-RT tubing, or both. Fittings and crimp rings shall meet the material and dimensional requirements of this standard. PEX tubing shall meet the requirements of Specification **F876**. PE-RT tubing shall meet the requirements of Specifications **F2623** and **F2769**. Assembly of test specimens shall be in accordance with Section **10**. Use separate sets of assemblies for each performance test requirement.

7.2 *Hydrostatic Burst*—Assemblies shall meet the minimum hydrostatic burst requirements shown in **Table 1**, when tested in accordance with **11.5**.

7.3 *Hydrostatic Sustained Pressure Strength*—Assemblies shall meet the hydrostatic sustained pressure requirements shown in **Table 2** when tested in accordance with **11.6**.

7.4 *Thermocycling*—Assemblies shall not leak or separate when thermocycled 1000 cycles between the temperatures of 60°F (16°C) and 180°F (82°C) when tested in accordance with **11.7**.

7.5 *Excessive Temperature-Pressure Capability:*

7.5.1 *General*—Assemblies shall have adequate strength to accommodate short-term conditions, 30 days (720 h) of 210°F (99°C) and 150 psi (1034 kPa) when tested in accordance with **11.8**.

³ Available from American National Standards Institute (ANSI), 25 W. 43rd St., 4th Floor, New York, NY 10036, <http://www.ansi.org>.

⁴ Available from NSF International, P.O. Box 130140, 789 N. Dixboro Rd., Ann Arbor, MI 48113-0140, <http://www.nsf.org>.

TABLE 1 Minimum Hydrostatic Burst Strength Requirements for Fitting, Crimp Ring, and PEX Tubing or PE-RT Tubing Assemblies

Nominal Tubing Size	Minimum Burst Pressures at Different Temperatures			
	psig ^A at 73.4°F	(kPa) at (23°C)	psig ^A at 180°F	(kPa) at (82.2°C)
3/8	620	(4275)	275	(1896)
1/2	480	(3309)	215	(1482)
3/4 and larger	475	(3275)	210	(1448)

^A The fiber stress to derive this test pressure is: at ~~73.4°F (23.0°C)~~ 73.4 °F (23.0 °C) 1900 psi (13.10 MPa) at ~~180°F (82.2°C)~~ 180 °F (82.2 °C) 850 psi (5.86 MPa).

TABLE 2 Minimum Hydrostatic Sustained Pressure Requirements for Fitting, Crimp Ring and PEX or PE-RT Tubing Assemblies^{A,B}

Nominal Tubing Size	Pressure Required for Test, psig (kPa)	
	180°F 180 °F	(82.2°C) (82.2 °C)
3/8	250	(1724)
1/2	195	(1344)
3/4 and larger	190	(1310)

^A The fiber stress to derive this test pressure is: 770 psi (5.31 MPa) at ~~180°~~ 180 ° F (~~82.2°C~~)(82.2 °C).

^B Test duration is 1000 h.

8. Dimensions

8.1 *Dimensions and Tolerances*—The dimensions and tolerances of fittings shall be as shown in Fig. 1, when measured in accordance with 11.4.

8.1.1 *Alignment*—The maximum angular variation of any opening shall not exceed 1° off the true centerline axis.

8.1.2 *Tapered Threads*—Fitting threads shall be American National Standard Taper Pipe Thread Form conforming to Specification F1498.

8.1.3 *Straight Threads*—Straight pipe threads, intended for the making of a gasketed seal with taper pipe threads, shall be NPSM and conform to ASME B 1.20.1.

9. Workmanship, Finish, and Appearance

9.1 The sealing surfaces of the insert shall be smooth and free of foreign material. The fitting walls shall be free of cracks, holes, blisters, voids, foreign inclusions, or other defects that are visible to the unaided eye and that affect the wall integrity.

9.2 Except for the insert, the molded part shall be free of flash in excess of 0.005 in. Flash, mismatch, and witness mark requirements for the insert shall be in accordance with Fig. 1.

10. Assembly

10.1 *Crimp Joints*—Insert fittings shall be joined to PEX tubing or PE-RT tubing by the compression of a copper crimp ring around the outer circumference of the tubing forcing the tubing material into annular spaces formed by ribs on the fitting. Insert fittings and crimp rings shall meet the dimensional and material requirements of this standard. PEX tubing shall meet the requirements of Specifications F876. PE-RT tubing shall meet the requirements of Specifications F2623 and F2769. The dimensions and out-of-roundness of the crimp ring after it has been crimped shall be in accordance with Table 3.

10.1.1 *Crimping Procedure*—To affix the insert fitting to the tubing with the crimp ring, the crimping procedure shall be as follows: slide the crimp ring onto the tubing, insert the ribbed end of the fitting into the end of the tubing until the tubing contacts the shoulder of the fitting or tube stop. The crimp ring shall then be positioned on the tubing so the edge of the crimp ring is 1/8 in. to 1/4 in. (3.2 to 6.4 mm) from the end of the tube. The jaws of the crimping tool shall be centered over the crimp ring and the tool shall be held so that the crimping jaws are approximately perpendicular to the axis of the barb. The jaws of the crimping tool shall be closed around the crimp ring, compressing the crimp ring onto the tubing. The crimp ring shall not be crimped more than once. Each crimp shall be checked to determine conformance to the after crimped dimensional requirements of Table 3.

11. Test Methods

11.1 *Conditioning*—Condition specimens at 73 ± 4°F (23 ± 2°C) and 50 ± 5 % relative humidity for not less than 4 h prior to testing. Test Method D618 shall be used to the extent possible as a guide to other conditions.

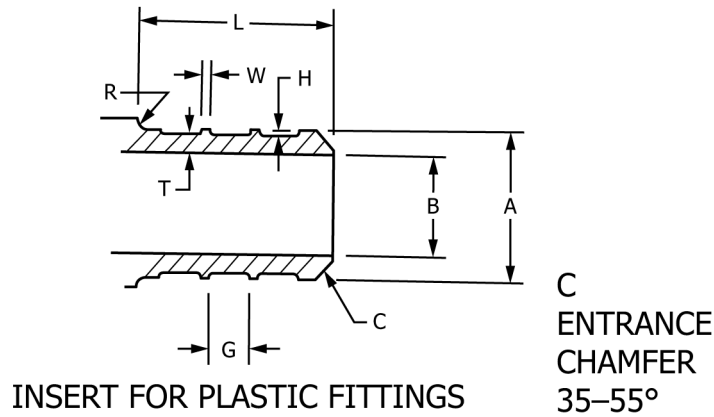

SIZE	A OUTSIDE DIAMETER	B MINIMUM ID	L INSERT LENGTH ^B	H MINIMUM RIB HEIGHT	NUMBER OF RIBS ^E	W RIB WIDTH TYP	G GAP WIDTH TYP	T MINIMUM WALL ^A	R MINIMUM RADIUS	MAXIMUM FLASH AND MISMATCH TOTAL ON CREST DIAMETER ^{D,F}
3/8"	0.347±.003	0.197	0.70+.020	0.015	2	0.03-0.05	0.135- 0.152	0.050	0.03	0.005
1/2"	0.473±.003	0.315	0.70+.020	0.015	2	0.03-0.05	0.135- 0.152	0.056	0.03	0.005
3/4"	0.668±.003	0.460	0.70+.020	0.015	2	0.03-0.05	0.135- 0.152	0.082	0.03	0.005
1"	0.856±.003	0.610	0.85+.020	0.015	3	0.03-0.05	0.135- 0.152	0.100	0.03	0.005

^A APPLIES TO ENTIRE FITTING NOT JUST INSERT AREA.

^B FITTING SHALL BE DESIGNED WITH SUFFICIENT OVERALL DIMENSIONS TO ALLOW PROPER USE OF CRIMP TOOL WITHOUT INTERFERENCE WITH PREVIOUSLY COMPLETED CRIMPS ON THE SAME FITTING.

^C THE MAXIMUM FLASH AND MISMATCH AT THE ROOT DIAMETER BETWEEN THE RIBS MAY NOT EXCEED 30% OF THE RIB HEIGHT.

^D THE TOTAL FLASH AND MISMATCH IS ASSUMED TO BE THE DIFFERENCE BETWEEN THE DIMENSIONS X AND Y (SEE FIG. 1A). THESE DIMENSIONS MAY BE MEASURED WITH APPROPRIATE CALIPERS OR MICROMETERS. SEE FIG. 1B FOR A GRAPHIC DEFINITION OF FLASH AND MISMATCH CREATED BY IMPERFECTION IN DIE HALF INTERFACES.

^E LEAD CHAMFER AREA IS NOT CONSIDERED A RIB.

^F THE MINIMUM ID SHALL BE MAINTAINED THROUGH THE INSERT LENGTH AND INTO THE FITTING, INTERSECTING THE MINIMUM ID OF THE OTHER FITTING INSERT(S).

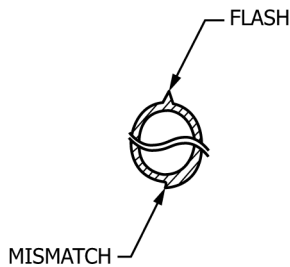

FIG. 1A FLASH AND MISMATCH CREATED BY IMPERFECTION IN DIE HALF INTERFACES.

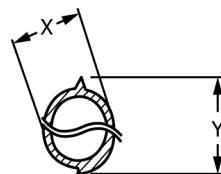

FIG. 1B TOTAL FLASH AND MISMATCH

FIG. 1 Fitting Insert Dimensions and Tolerances