



Designation: **D648 – 16 D648 – 18**

Standard Test Method for Deflection Temperature of Plastics Under Flexural Load in the Edgewise Position¹

This standard is issued under the fixed designation D648; the number immediately following the designation indicates the year of original adoption or, in the case of revision, the year of last revision. A number in parentheses indicates the year of last reapproval. A superscript epsilon (ϵ) indicates an editorial change since the last revision or reapproval.

This standard has been approved for use by agencies of the U.S. Department of Defense.

1. Scope*

1.1 This test method covers the determination of the temperature at which an arbitrary deformation occurs when specimens are subjected to an arbitrary set of testing conditions.

1.2 This test method applies to molded and sheet materials available in thicknesses of 3 mm ($\frac{1}{8}$ in.) or greater and which are rigid or semirigid at normal temperature.

NOTE 1—Sheet stock less than 3 mm (0.125 in.) but more than 1 mm (0.040 in.) in thickness may be tested by use of a composite sample having a minimum thickness of 3 mm. The laminae must be of uniform stress distribution. One type of composite specimen has been prepared by cementing the ends of the laminae together and then smoothing the edges with sandpaper. The direction of loading shall be perpendicular to the edges of the individual laminae.

1.3 The values stated in SI units are to be regarded as standard. The values given in parentheses are for information only.

1.4 Some older machines still use mercury-in-glass thermometers. (**Warning**—Mercury has been designated by many regulatory agencies as a hazardous material that can cause serious medical issues. Mercury, or its vapor, has been demonstrated to be hazardous to health and corrosive to materials. Caution should be taken when handling mercury and mercury containing products. See the applicable product Safety Data Sheet (SDS) for additional information. Users should be aware that selling mercury and/or mercury containing products into your state or country may be prohibited by law.

1.5 This standard does not purport to address all of the safety concerns, if any, associated with its use. It is the responsibility of the user of this standard to establish appropriate safety, health, and environmental practices and determine the applicability of regulatory limitations prior to use.

NOTE 2—The text of this standard references notes and footnotes that provide explanatory material. These notes and footnotes (excluding those in tables and figures) shall not be considered as requirements of the standard.

NOTE 3—This standard and ISO 75-1 and ISO 75-2 address the same subject matter, but differ in technical content, and results shall not be compared between the two test methods.

NOTE 2—The text of this standard references notes and footnotes that provide explanatory material. These notes and footnotes (excluding those in tables and figures) shall not be considered as requirements of the standard.

NOTE 3—This standard and ISO 75-1 and ISO 75-2 address the same subject matter, but differ in technical content, and results shall not be compared between the two test methods.

1.6 This international standard was developed in accordance with internationally recognized principles on standardization established in the Decision on Principles for the Development of International Standards, Guides and Recommendations issued by the World Trade Organization Technical Barriers to Trade (TBT) Committee.

2. Referenced Documents

2.1 ASTM Standards:²

D618 Practice for Conditioning Plastics for Testing

D883 Terminology Relating to Plastics

D4000 Classification System for Specifying Plastic Materials

D5947 Test Methods for Physical Dimensions of Solid Plastics Specimens

¹ This test method is under the jurisdiction of ASTM Committee D20 on Plastics and is the direct responsibility of Subcommittee D20.30 on Thermal Properties. Current edition approved April 1, 2016 April 1, 2018. Published April 2016 April 2018. Originally approved in 1941. Last previous edition approved in 2007 2016 as D648 – 07 D648 - 16., which was withdrawn January 2016 and reinstated in April 2016. DOI: 10.1520/D0648-16. DOI: 10.1520/D0648-18.

² For referenced ASTM standards, visit the ASTM website, www.astm.org, or contact ASTM Customer Service at service@astm.org. For Annual Book of ASTM Standards volume information, refer to the standard's Document Summary page on the ASTM website.

*A Summary of Changes section appears at the end of this standard

[E1 Specification for ASTM Liquid-in-Glass Thermometers](#)
[E77 Test Method for Inspection and Verification of Thermometers](#)
[E608/E608M Specification for Mineral-Insulated, Metal-Sheathed Base Metal Thermocouples](#)
[E691 Practice for Conducting an Interlaboratory Study to Determine the Precision of a Test Method](#)
[E1137/E1137M Specification for Industrial Platinum Resistance Thermometers](#)
[E2251 Specification for Liquid-in-Glass ASTM Thermometers with Low-Hazard Precision Liquids](#)

2.2 *ISO Standards*:³

[ISO 75-1 Plastics—Determination of Temperature of Deflection Under Load—Part 1: General Test Method](#)

[ISO 75-2 Plastics—Determination of Temperature of Deflection Under Load—Part 2: Plastics and Ebonite](#)

2.3 *NIST Document*:⁴

[NBS Special Publication 250-22](#)

3. Terminology

3.1 *General*—The definitions of plastics used in this test method are in accordance with Terminology [D883](#) unless otherwise indicated.

4. Summary of Test Method

4.1 A bar of rectangular cross section is tested in the edgewise position as a simple beam with the load applied at its center to give maximum fiber stresses of 0.455 MPa (66 psi) or 1.82 MPa (264 psi) ([Note 4](#)). The specimen is immersed under load in a heat-transfer medium provided with a means of raising the temperature at $2 \pm 0.2^\circ\text{C}/\text{min}$. The temperature of the medium is measured when the test bar has deflected 0.25 mm (0.010 in.). This temperature is recorded as the deflection temperature under flexural load of the test specimen.

NOTE 4—A round robin has been conducted that showed that there is no advantage to using higher loads when measuring deflection temperature of present-day plastics with present-day instruments.

5. Significance and Use

5.1 This test is particularly suited to control and development work. Data obtained by this test method shall not be used to predict the behavior of plastic materials at elevated temperatures except in applications in which the factors of time, temperature, method of loading, and fiber stress are similar to those specified in this test method. The data are not intended for use in design or predicting endurance at elevated temperatures.

5.2 For many materials, there may be a specification that requires the use of this test method, but with some procedural modifications that take precedence when adhering to the specification. Therefore, it is advisable to refer to that material specification before using this test method. Refer to [Table 1 in Classification D4000](#), which lists the ASTM material standards that currently exist.

6. Interferences

6.1 The results of the test are dependent on the rate of heat transfer between the fluid and the specimen and the thermal conductivity of the fluid.

6.2 The results of this test are dependent on the measured width and depth of the specimen and the final deflection at which the deflection temperature is determined.

6.3 The type of mold and the molding process used to produce test specimens affects the results obtained in this test. Molding conditions shall be in accordance with the standard for that material or shall be agreed upon by the cooperating laboratories.

6.4 Results of testing are affected by the design of the test equipment. The test span (either 100 mm or 101.6 mm) will influence the resultant measurement. Instrumentation equipped with metal clips or other types of auxiliary supports designed to maintain specimens perpendicular to the applied load will affect the test results if the pressure is sufficient to restrict the downward motion of the specimen at its center.

7. Apparatus

7.1 The apparatus shall be constructed essentially as shown in [Fig. 1](#) and shall consist of the following:

7.1.1 *Specimen Supports*, metal supports, allowing the load to be applied on top of the specimen vertically and midway between the supports, which shall be separated by a distance, defined in [7.1.1.1](#) or [7.1.1.2](#). The contact edges of the supports and of the piece by which load is applied shall be rounded to a radius of 3 ± 0.2 mm (0.118 ± 0.008 in.).

7.1.1.1 Method A— 101.6 ± 0.5 mm (4.0 ± 0.02 in.).

³ Available from American National Standards Institute (ANSI), 25 W. 43rd St., 4th Floor, New York, NY 10036, <http://www.ansi.org>.

⁴ Mangum, B. W., "Platinum Resistance Thermometer Calibration," *NBS Special Publication 250-22*, 1987. Available from National Institute of Standards and Technology, Gaithersburg, MD.

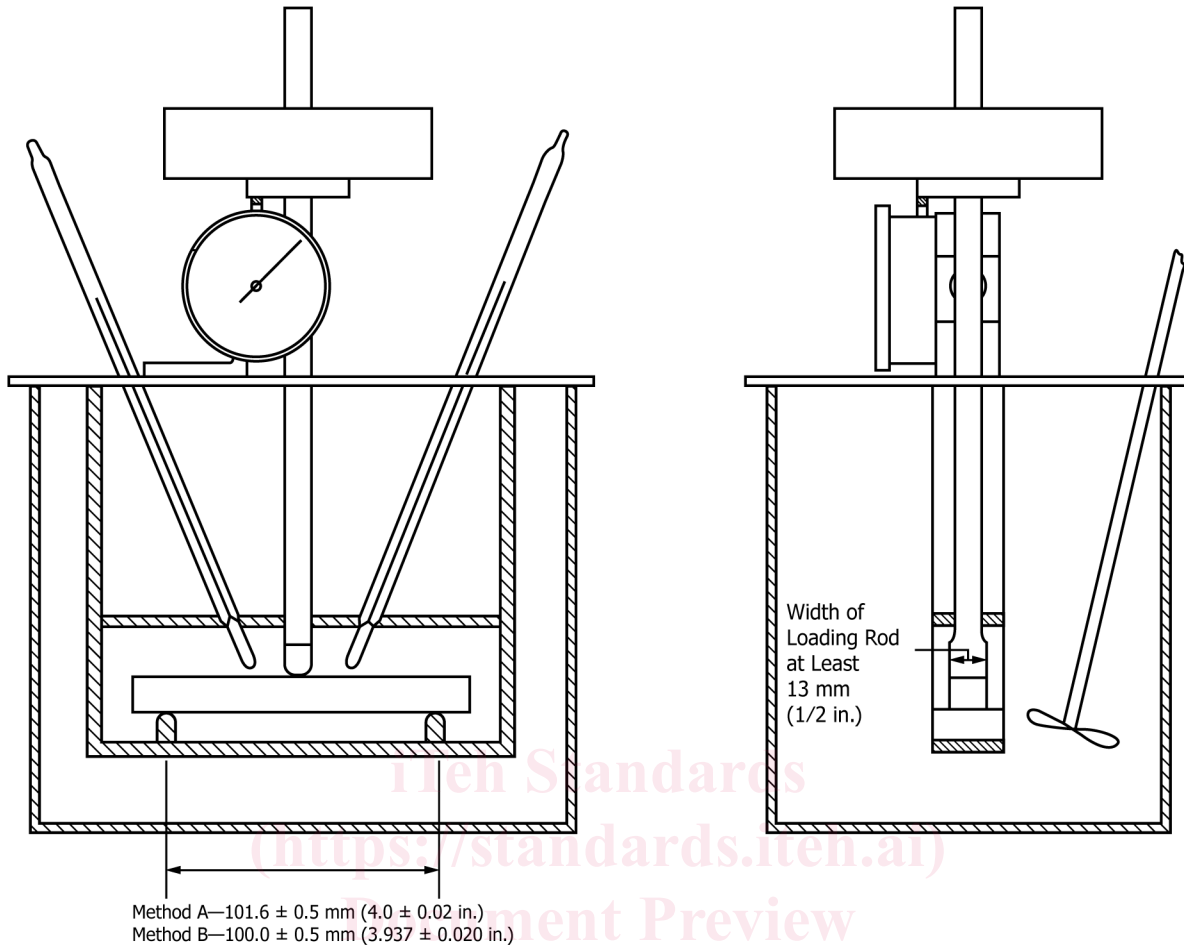

FIG. 1 Apparatus for Deflection Temperature Test

7.1.1.2 Method B—100.0 ± 0.5 mm (3.937 ± 0.020 in.).

7.1.2 *Immersion Bath*—Choose a suitable liquid heat-transfer medium (Note 5) in which the specimen shall be immersed, which will not affect the specimen. It shall be well-stirred during the test and shall be provided with a means of raising the temperature at a uniform rate of 2 ± 0.2°C/min. This heating rate shall be considered to be met if, over every 5-min interval during the test, the temperature of the bath shall rise 10 ± 1°C at each specimen location.

NOTE 5—Mineral oil is considered safe from ignition to 115°C. Silicone oils may be heated to about 260°C for short periods of time. For still higher temperatures, special heat-transfer media should be used. Improved performance with longer oil life may be obtained by the use of CO₂ or other inert gas to isolate the oil surface from the atmosphere.

7.1.3 *Deflection Measurement Device*, suitable for measuring specimen deflection of at least 0.25 mm (0.010 in.). It shall be readable to 0.01 mm (0.0005 in.) or better. Dial gauges or any other indicating or recording device, including electric displacement sensing apparatus, are acceptable.

7.1.4 *Weights*—A set of weights of suitable sizes so that the specimen are loaded to a fiber stress of 0.455 MPa (66 psi) ± 2.5 % or 1.82 MPa (264 psi) ± 2.5 %. The mass of the rod that applies the testing force shall be determined and included as part of the total load. If a dial gauge is used, the force exerted by its spring shall be determined and shall be included as part of the load (Note 9). Calculate the testing force and the mass that must be added to achieve the desired stress as follows:

$$F = 2Sbd^2/3L \tag{1}$$

$$F^1 = F/9.80665$$

$$m_w = (F - F_s)/9.80665 - m_r$$

where:

- F = load, N,
- F¹ = load, kgf,
- S = fiber stress in the specimen (0.455 MPa or 1.82 MPa),

- b = width of specimen, mm,
 d = depth of specimen, mm,
 L = distance between supports, (101.6 mm—Method A, or 100 mm—Method B), see 7.1.1.1 and 7.1.1.2.
 m_w = added mass, kg,
 F_s = force exerted by any spring-loaded component involved, N; this is a positive value if the thrust of the spring is towards the test specimen (downwards), or a negative value if the thrust of the spring is opposing the descent of the rod, or zero if no such component is involved, and
 m_r = mass of the rod that applies the testing force to the specimen, kg.

NOTE 6—In some designs of this apparatus, the spring force of the dial gauge is directed upward (opposite the direction of specimen loading), which reduces the net force applied to the specimen. In other designs, the spring force of the dial gauge acts downward (in the direction of specimen loading), which increases the net force applied to the specimen. The mass applied to the loading rod must be adjusted accordingly (increased for upward dial force and decreased for downward dial force) to compensate. Since the force exerted by the spring in certain dial gauges varies considerably over the stroke, this force should be measured in that part of the stroke that is to be used. Suggested procedures to determine the total load required to correct for the force of the dial gauge spring are given in Appendix X1 and Appendix X2. Other procedures may be used if equivalent results are obtained. Appendix X3 provides a method of determining the spring force, uniformity of the force in the gauge's test measurement range, and whether the gauge is contaminated and sticking.

7.1.5 Temperature Measurement System

7.1.5.1 *Digital Indicating System*—Consisting of a thermocouple, resistance thermometer (RTD), and so forth, as the sensor, together with associated conditioning, conversion, and readout instrumentation adequate to cover the range being tested. The sensor and related electronics shall be accurate to at least $\pm 0.5^\circ\text{C}$. Thermocouples shall comply with the requirements of Specification E608/E608M. Resistance thermometers shall comply with the requirements of Specification E1137/E1137M.

7.1.5.2 *Thermometer*—Older systems still in existence use a thermometer for temperature measurement at each individual test station. The thermometer shall be one of the following, or its equivalent, as prescribed in Specification E1: Thermometer 1C or 2C, having ranges from -20 to 150°C or -5 to 300°C respectively, whichever temperature range is most suitable. Liquid-in-glass thermometers shall be calibrated for the depth of immersion in accordance with Test Method E77.

NOTE 7—Consult Specification E2251 for suitable alternatives to mercury-in-glass thermometers.

7.2 *Micrometers* shall meet the requirements of Test Methods D5947 and be calibrated in accordance with that test method.

8. Sampling

8.1 Sample in a statistically acceptable manner. When samples are taken from a production lot or process, the process shall be in a state of statistical control.

9. Test Specimen

9.1 At least two test specimens of the same nominal width shall be used to test each sample at each fiber stress. The length of the specimen shall be 127 mm (5 in.) in length, 13 mm (at a minimum be the distance between supports + 12.7 mm (0.500 in.)). The depth of the specimen must be 12.7 mm \pm 0.5 $\frac{1}{2}$ in.) in depth by mm (0.500 \pm 0.020 in.). The width of the specimen shall be any width from 3 mm ($\frac{1}{8}$ in.) to 13 mm ((0.118 $\frac{1}{2}$ in. to 0.512 in.).

NOTE 8—Tolerances on the depth and width dimensions (for highly reproducible work) should be of the order of ± 0.13 mm (0.005 in.) along the length of the specimen. specimen to minimize variations.

NOTE 9—The test results obtained on specimens approaching 13 mm in width may be 2 to 4°C above those obtained from 4 mm or narrower test specimens because of poor heat transfer through the specimen.

9.2 The specimens shall have smooth flat surfaces free from saw cuts, excessive sink marks, or flash.

9.3 Molding conditions shall be in accordance with the specification for that material or shall be agreed upon by the cooperating laboratories. Discrepancies in test results due to variations in molding conditions are often minimized by annealing the test specimens before the test. Since different materials require different annealing conditions, annealing procedures shall be employed only if required by the material standard or if agreed upon by the cooperating laboratories.

10. Preparation of Apparatus

10.1 The apparatus shall be arranged so that the deflection of the specimen at midspan is measured by the deflection measurement device described in 7.1.3. It is acceptable if the apparatus is arranged to shut off the heat automatically and sound an alarm or record the temperature when the specific deflection has been reached. Sufficient heat transfer liquid shall be used to cover the sensing end of the temperature measuring device to the point specified in their calibration.

NOTE 10—It is desirable to have a means to cool the bath in order to reduce the time required to lower the temperature of the bath after the test has been completed. This may be accomplished by using a cooling coil installed in the bath, or an external heat transfer system that passes the hot oil through it. If the rate of temperature rise of the oil is adversely affected by the presence of residual coolant in the coils, the coolant should be purged prior to starting the next test.

11. Conditioning

11.1 *Conditioning*—Condition the test specimens in accordance with Procedure A of Practice D618 unless otherwise specified by contract or the relevant ASTM material specification. Conditioning time is specified as a minimum. Temperature and humidity tolerances shall be in accordance with Section 7 of Practice D618 unless specified differently by contract or material specification.

NOTE 11—Shorter conditioning periods may be used when it is shown that they do not affect the results of this test. Longer conditioning times may be required for some materials that continue to change with time.

12. Procedure

12.1 Measure the width and depth of each specimen with a suitable micrometer (as described in 7.2) at three points along the span. Average these respective readings to obtain the nominal width and depth value for the specimen. These values are used to determine the amount of applied force necessary to produce the specified fiber stress in each specimen (see 7.1.4).

12.2 Position the test specimens edgewise in the apparatus and ensure that they are properly aligned on the supports so that the direction of the testing force is perpendicular to the direction of the molding flow. If the specimen support unit has metal clips or auxiliary supports on it to hold the specimen perpendicular to the load and to prevent the specimen from being displaced by the circulating oil, only one surface of the clip or auxiliary support shall touch the specimen at any one time. The presence of any clip or auxiliary support shall not impede the deflection of the specimen or place additional force on the specimen that will result in more load having to be applied to achieve deflection.

NOTE 12—Holding of the specimens upright on the specimen supports by the use of clips or auxiliary supports that apply pressure to the specimen have been shown to alter the deflection temperature when testing at the 0.45 MPa stress level.

12.3 The sensitive part of the temperature measuring device shall be positioned as close as possible to the test specimen (within 10 mm) without touching it. The stirring of the liquid-heat transfer medium shall be sufficient to ensure that temperature of the medium is within 1.0°C at any point within 10 mm of the specimen. If stirring is not sufficient to meet the 1.0°C requirement, then the temperature measuring device shall be placed at the same level as the specimen and within 10 mm of the point at which the specimen is loaded.

12.4 Ascertain that the temperature of the bath is suitable. The bath temperature shall be at ambient temperature at the start of the test unless previous tests have shown that, for the particular material under test, no error is introduced by starting at a higher temperature.

12.5 Carefully apply the loaded rod to the specimen and lower the assembly into the bath.

12.6 Adjust the load so that the desired stress of 0.455 MPa (66 psi) or 1.82 MPa (264 psi) is obtained.

NOTE 13—Verification of the load should be made on all new equipment, after replacement of dial gauges, or following any other change that could affect the loading. Verification of the load should also be performed periodically to ensure that the equipment is within calibration (see Appendix X1, Appendix X2, and Appendix X3). Depending on the type of deflection measurement device used, it may be necessary to adjust the device such that it records the deflection in the displacement range of the device where the test is to be made.

12.7 Five minutes after applying the load, adjust the deflection measurement device to zero or record its starting position. Heat the liquid heat-transfer medium at a rate of $2.0 \pm 0.2^\circ\text{C}/\text{min}$.

NOTE 14—The 5-min waiting period is provided to compensate partially for the creep exhibited by some materials at room temperature when subjected to the specified nominal surface stress. That part of the creep that occurs in the initial 5 min is usually a significant fraction of that which occurs in the first 30 min.

12.8 Record the temperature of the liquid heat-transfer medium at which the specimen has deflected the specified amount at the specified fiber stress.

NOTE 15—Continuous reading of the deflection versus temperature even beyond the standard deflection might be useful in special situations.

13. Report

13.1 Report the following information:

- 13.1.1 Full identification of the material tested,
- 13.1.2 Method of test specimen preparation,
- 13.1.3 Conditioning procedure,
- 13.1.4 Test method, reported as D648 Method A or D648 Method B,
- 13.1.5 The width and depth of the specimen, measured to 0.025 mm,
- 13.1.6 The standard deflection, the deflection temperature, and the resultant maximum fiber stress for each specimen,
- 13.1.7 The immersion medium, the temperature at the start of the test, and the actual heating rate,
- 13.1.8 Average deflection temperature,
- 13.1.9 Any nontypical characteristics of the specimen noted during the test or after removal from the apparatus, (such as twisting, nonuniform bending, discoloration, swelling), and
- 13.1.10 Type of apparatus: automated or manual.

TABLE 1 Statistical Information^A

Polymer	Average ^B Value	Standard Deviation	Critical ^C Difference, Within Laboratories	Critical Difference, Between Laboratories
Polyethylene, 0.455 MPa	85.3	4.8	6.0	9.4
Polycarbonate, 0.455 MPa	142.0	2.0	2.3	3.9
Methyl methacrylate, 1.82 MPa	97.6	2.9	4.0	5.7
Polysulfone, 1.82 MPa	173.8	2.8	2.3	5.5

^AAll values are given in °C.

^BAverage of pairs.

^CBetween values of a pair.

TABLE 2 Precision, Deflection Temperature

Material	Units Expressed in °C				
	Average	S_r^A	S_R^B	r^C	R^D
ABS, 1.8 MPa	81.6	1.15	1.67	3.21	4.68
PP natural, 0.45 MPa	83.8	3.11	4.71	8.70	13.20
PP filled, 0.45 MPa	114.7	2.16	4.62	6.06	12.92

^A S_r = within-laboratory standard deviation for the indicated material. It is obtained by pooling the within-laboratory standard deviations of the test results from all of the participating laboratories:

$$S_r = [((S_1)^2 + (S_2)^2 + \dots + (S_n)^2)/n]^{1/2}$$

^B S_R = between-laboratories reproducibility, expressed as standard deviation:

$$S_R = [S_r^2 + S_L^2]^{1/2}, \text{ where } S_L = \text{standard deviation of laboratory means.}$$

^C r = within-laboratory critical interval between two test results = $2.8 \times S_r$
^D R = between-laboratories critical interval between two test results = $2.8 \times S_R$
TABLE 3 Deflection Temperature (Average) Obtained on Test Equipment With Span Values of 100 and 101.6 mm (3.937 and 4.0 in.), °C

Material	100-mm (3.937-in.) Span	101.6-mm. (4.0-in.) Span
ABS, 1.8 MPa	81.9	81.0
PP natural, 0.45 MPa	85.2	80.9
PP filled, 0.45 MPa	116.6	112.0
Nylon, 1.8 MPa	156.1	153.8

14. Precision and Bias

14.1 *Precision*—An interlaboratory test program⁵ was carried out with seven laboratories participating and utilizing both manual and automated instruments. Four polymers were included in the program. Statistical information is summarized in **Table 1**. The critical difference limits are the limits beyond which observed differences are to be considered suspect.

14.2 In 1995 a second round-robin⁶ study was conducted. **Table 2** is based on this round robin conducted in accordance with Practice **E691**, involving three materials tested by 15 laboratories. For each material, all the samples were prepared at one source, but the individual specimens were prepared at the laboratories that tested them. Each test result was the average of two individual determinations. Each laboratory obtained four test results for each material. (**Warning**—The following explanation for r and R (14.3 – 14.3.3) are only intended to present a meaningful way of considering the approximate precision of this test method. The data in **Table 2** shall not be applied to acceptance or rejection of material, as these data apply only to materials tested in the round robin and are unlikely to be rigorously representative of the other lots, formulations, conditions, material, or laboratories. Users of this test method shall apply the principles outlined in Practice **E691** to generate data specific to their materials and laboratory (or between specific laboratories). The principles of 14.3 – 14.3.3 would then be valid for such data.)

14.3 *Concept of r and R in Table 2*—If S_r and S_R have been calculated from a large enough body of data, and for test results that were averages from testing two specimens for each test result, then:

⁵ Supporting data have been filed at ASTM International Headquarters and may be obtained by requesting Research Report RR:D20-1098.

⁶ Supporting data have been filed at ASTM International Headquarters and may be obtained by requesting Research Report RR:D20-1202.