



Designation: C1063 – 18a

# Standard Specification for Installation of Lathing and Furring to Receive Interior and Exterior Portland Cement-Based Plaster<sup>1</sup>

This standard is issued under the fixed designation C1063; the number immediately following the designation indicates the year of original adoption or, in the case of revision, the year of last revision. A number in parentheses indicates the year of last reapproval. A superscript epsilon ( $\epsilon$ ) indicates an editorial change since the last revision or reapproval.

*This standard has been approved for use by agencies of the U.S. Department of Defense.*

## 1. Scope\*

1.1 This specification covers the minimum technical requirements for lathing and furring for the application of exterior and interior portland cement-based plaster, as in Specifications C841 or C926. These requirements do not by default define a unit of work or assign responsibility for contractual purposes, which is the purview of a contract or contracts made between contracting entities.

1.2 Where a fire resistance rating is required for plastered assemblies and constructions, details of construction shall be in accordance with reports of fire tests of assemblies that have met the requirements of the fire rating imposed.

1.3 Where a specific degree of sound control is required for plastered assemblies and constructions, details of construction shall be in accordance with official reports of tests conducted in recognized testing laboratories in accordance with the applicable requirements of Test Method E90.

1.4 The values stated in inch-pound units are to be regarded as standard. The values given in parentheses are mathematical conversions to SI units that are provided for information only and are not considered standard.

1.5 *This international standard was developed in accordance with internationally recognized principles on standardization established in the Decision on Principles for the Development of International Standards, Guides and Recommendations issued by the World Trade Organization Technical Barriers to Trade (TBT) Committee.*

<sup>1</sup> This specification is under the jurisdiction of ASTM Committee C11 on Gypsum and Related Building Materials and Systems and is the direct responsibility of Subcommittee C11.03 on Specifications for the Application of Gypsum and Other Products in Assemblies.

Current edition approved April 1, 2018. Published April 2018. Originally approved in 1986. Last previous edition approved in 2018 as C1063 – 18. DOI: 10.1520/C1063-18A.

## 2. Referenced Documents

### 2.1 ASTM Standards:<sup>2</sup>

A653/A653M Specification for Steel Sheet, Zinc-Coated (Galvanized) or Zinc-Iron Alloy-Coated (Galvannealed) by the Hot-Dip Process

C11 Terminology Relating to Gypsum and Related Building Materials and Systems

C841 Specification for Installation of Interior Lathing and Furring

C847 Specification for Metal Lath

C926 Specification for Application of Portland Cement-Based Plaster

C933 Specification for Welded Wire Lath

C1032 Specification for Woven Wire Plaster Base

C1280 Specification for Application of Exterior Gypsum Panel Products for Use as Sheathing

C1861 Specification for Lathing and Furring Accessories, and Fasteners, for Interior and Exterior Portland Cement-Based Plaster

E90 Test Method for Laboratory Measurement of Airborne Sound Transmission Loss of Building Partitions and Elements

### 2.2 US Department of Commerce (DOC) Standards

PS 1 Voluntary Product Standard PS 1, Structural Plywood

PS 2 Voluntary Product Standard PS 2, Performance Standard for Wood-Based Structural Use Panels

## 3. Terminology

### 3.1 Definitions:

3.1.1 For definitions relating to ceilings and walls, see Terminology C11.

3.1.2 For definitions relating to lathing accessories, furring accessories and fasteners, see Specification C1861.

### 3.2 Definitions of Terms Specific to This Standard:

3.2.1 *building enclosure, n*—system of building assemblies and materials designed and installed in such a manner as to provide a barrier between different environments.

<sup>2</sup> For referenced ASTM standards, visit the ASTM website, www.astm.org, or contact ASTM Customer Service at service@astm.org. For *Annual Book of ASTM Standards* volume information, refer to the standard's Document Summary page on the ASTM website.

\*A Summary of Changes section appears at the end of this standard

3.2.2 *control joint, n*—a joint that accommodates movement of plaster shrinkage and curing along predetermined, usually straight, lines.

3.2.3 *expansion joint, n*—a joint that accommodates movement beyond plaster shrinkage and curing.

NOTE 1—For design consideration of control and expansion joints, see Annex A2.3.1.2 of Specification C926.

3.2.4 *framing member, n*—studs, joist, runners (track), bridging, bracing, and related accessories manufactured or supplied in wood or light gauge steel.

3.2.5 *hangers, n*—wires or steel rods or straps used to support main runners for suspended ceilings beneath floor or roof constructions.

3.2.6 *inserts, n*—devices embedded in concrete framing members to provide a loop or opening for attachment of hangers.

3.2.7 *saddle tie, n*—see Figs. 1 and 2.

3.2.8 *self-furring, adj*—a metal plaster base manufactured with evenly-spaced indentations that hold the body of the lath approximately 1/4 in. (6 mm) away from solid surfaces to which it is installed.

3.2.9 *water resistive barrier, n*—a material that resists the infiltration of liquid moisture through the building enclosure system.

#### 4. Delivery and Storage of Materials

##### 4.1 Delivery of Materials:

4.1.1 All materials shall be delivered in the original packages, containers, or bundles bearing the brand-name and manufacturer's (or supplier's) identification.

##### 4.2 Storage of Materials:

4.2.1 All materials shall be kept dry. Materials shall be stacked off the ground, supported on a level platform, and protected from the weather and surface contamination.

4.2.2 Materials shall be neatly stacked with care taken to avoid damage to edges, ends, or surfaces.

4.2.3 Paper backed metal plaster bases shall be handled carefully in delivery, storage, and erection to prevent puncturing or removal of paper.

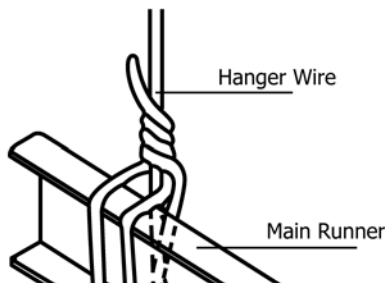

FIG. 1 Saddle Tie

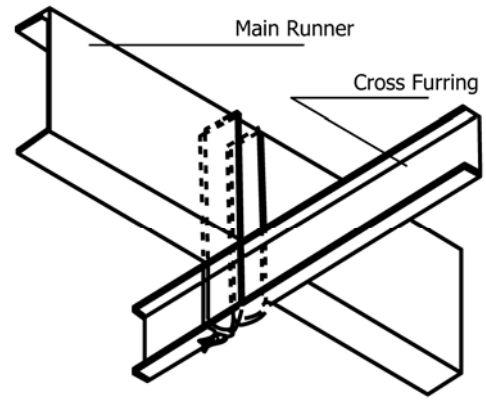

FIG. 2 Saddle Tie

#### 5. Materials

5.1 Metallic materials including lathing, lathing accessories, furring, furring accessories, and fasteners shall be selected for compatibility to minimize galvanic corrosion between adjacent metallic materials installed in the cement plaster cladding assembly.

##### 5.2 Metal Plaster Bases:

5.2.1 *Expanded Metal Lath*—Specification C847, galvanized.

##### 5.2.2 Wire Laths:

5.2.2.1 *Welded Wire Lath*—Specification C933.

5.2.2.2 *Woven Wire Lath*—Specification C1032.

5.2.2.3 *Paper Backed Plaster Bases*—Specification C847.

##### 5.3 Lathing Accessories, Furring Accessories and Fasteners:

5.3.1 *Lathing Accessories, Furring Accessories and Fasteners*—Specification C1861.

5.3.2 The selection of an appropriate type of material for lathing accessories shall be based upon applicable surrounding climatic and environmental conditions specific to the project location, such as salt air, industrial pollution, high moisture, or humidity.

#### 6. Requirements for Substrates to Receive Metal Lathing and Furring

##### 6.1 Framed, or Framed and Sheathed Substrates:

6.1.1 Framing member deflection shall not exceed L/360 (0.33 in. in 10 ft).

6.1.2 Plywood and oriented strand board sheathing panels shall be marked in accordance with DOC PS1 or DOC PS 2.

6.1.3 Plywood and oriented strand board sheathing panels shall be installed with 1/8 in. (3 mm) minimum panel edge gaps, and panel edges shall be offset 4 in. (10 cm) minimum from wall opening reentrant corners.

6.1.4 Wood framing members, plywood and oriented strand board sheathing panels shall have a moisture content not to exceed 19 % immediately before plastering.

6.1.5 Exterior gypsum sheathing panels shall be installed in compliance with Specification C1280.

#### 7. Installation

7.1 *Workmanship*—Metal lathing, lathing accessories, furring, and furring accessories shall be erected so that the

finished cement plaster surfaces are true to line (allowable tolerance of 1/4 in. (6 mm) in 10 ft (3 m)), level, plumb, square, or curved as required to receive the specified cement plaster thickness.

**7.2 Hangers and Inserts:**

7.2.1 Hangers shall be of ample length and shall conform to the requirements of **Table 1**, both as to size and maximum cement plaster panel area to be supported, except as modified in this section.

7.2.2 When strap hangers are used, 7/16-in. (11 mm) diameter holes shall be provided on the center line at the upper end of the strap hanger to permit the attachment of the strap hanger. The edge of the holes in the strap hangers shall be not less than 3/8 in. (10 mm) from the ends.

7.2.3 In concrete, rod or strap hangers shall be attached to inserts embedded in the concrete, or to other attachment devices designed for this purpose, and able to develop full strength of the hanger.

7.2.4 Strap hangers shall be bolted with machine bolts. (See **Fig. 3**.)

7.2.5 The nuts of the machine bolts shall be drawn up tight.

NOTE 2—Hangers required to withstand upward wind pressures shall be of a type to resist compression. Struts of formed channels shall be permitted.

**7.3 Installation of Hangers for Suspended Ceilings Under Wood Constructions**—Hangers shall be attached to framing members by any of the following methods:

7.3.1 A hole shall be drilled through the wood framing member not less than 3 in. (76 mm) above the bottom, with the upper end of the wire hanger passed through the hole and twisted three times around itself. (See **Fig. 4**.)

7.3.2 Three 12d nails shall be driven, on a downward slant, into the sides of the wood framing member with not less than 1 1/4 in. (32 mm) penetration and not less than 5 in. (127 mm) from the bottom edges, and not more than 36 in. (914 mm) on the center with the upper end of the wire hanger wrapped around the nails and twisted three times around itself. (See **Fig. 5**.)

7.3.3 A loop shall be formed in the upper end of the wire hanger and secured to the wood framing member by four 1 1/2-in. (38 mm), not less than 9 gauge, 0.1483-in. (3.77 mm) diameter wire staples driven horizontally or on a downward slant into the sides of the wood framing members, three near the upper end of the loop and the fourth to fasten the loose end. (See **Fig. 6**.)

7.3.4 Where framing members for flooring are thicker than 1 1/2 in. (38 mm) and are spaced more than 4 ft (1.2 m) on center, eye screws (or equivalent), spaced not more than 3 ft (914 mm) on centers shall be screwed into the flooring framing members with the upper end of the wire hanger inserted through the eye screws and twisted three times around itself.

7.3.5 Two holes shall be drilled in the upper end of the flat hangers and nailed to the sides of the wood framing members with 12d nails driven through the holes and clinched. Nails

**TABLE 1 Allowable Support or Hanger Wire Spacing ft-in. (mm) and Cold-Rolled Channel Furring Main Runner Spans, ft-in. (mm)<sup>1-7</sup>**

Member Size, in. (mm)	Member Weight, lb/1000 ft (kg/m)	Span Condition <sup>6,7</sup>	Uniform Load = 12 psf (0.479 kPa)				
			Member Spacing, in. (mm)				
			24 (610)	36 (914)	48 (1220)	60 (1520)	72 (1830)
			Allowable Hanger Wire or Support Spacing, ft-in. (mm)				
1 1/2 (38)	414 (0.615)	Single	3-6 (1070)	3-1 (940)	2-9 (840)	2-9 (790)	2-5 (740)
		2 or More	4-11 (1500)	4-2 (1270)	3-7 (1090)	3-2 (970)	2-11 (890)
2 (51)	506 (0.753)	Single	3-9 (1140)	3-3 (990)	3-0 (910)	2-9 (840)	2-8 (810)
		2 or More	5-2 (1570)	4-6 (1370)	4-1 (1240)	3-10 (1170)	3-7 (1090)
2 1/2 (64)	597 (0.888)	Single	3-11 (1190)	3-5 (1040)	3-2 (970)	2-11 (890)	2-9 (840)
		2 or More	5-5 (1650)	4-9 (1450)	4-4 (1320)	4.0 (1220)	3-10 (1170)
			Uniform Load = 15 psf (0.287 kPa)				
Member Size, in. (mm)	Member Weight, lb/1000 ft (kg/m)	Span Condition <sup>6,7</sup>	Member Spacing, in. (mm)				
			24 (610)	36 (914)	48 (1220)	60 (1520)	72 (1830)
1 1/2 (38)	414 (0.616)	Single	3-3 (990)	2-10 (860)	2-7 (790)	2-4 (710)	2-2 (660)
		2 or More	4-6 (1370)	3-8 (1120)	3-2 (970)	2-10 (860)	2-7 (790)
2 (51)	506 (0.753)	Single	3-6 (1070)	3-1 (940)	2-10 (880)	2-7 (790)	2-5 (740)
		2 or More	4-10 (1470)	4-3 (1300)	3-10 (1170)	3-6 (1070)	3-3 (990)
2 1/2 (64)	597 (0.888)	Single	3-8 (1120)	3-3 (990)	2-11 (890)	2-9 (840)	2-7 (790)
		2 or More	5-0 (1520)	4-5 (1350)	4-0 (1220)	3.9 (1140)	3-6 (1070)

**Allowable Spans Notes:**

<sup>1</sup> Spans based on upper flange of main runners laterally unbraced.

<sup>2</sup> Maximum deflection limited to 1/360 of the span length.

<sup>3</sup> Uniform load 12 psf (dry density) shall be used for portland cement plaster ceilings with plaster thicknesses up to 7/8 in. (22 mm) and 15 psf shall be used for ceilings with plaster thicknesses over 7/8 in. (22 mm) and not more than 1 1/4 in. (32 mm).

<sup>4</sup> "2 or More" spans refers to two or more continuous, equal spans.

<sup>5</sup> For the "2 or More" span condition, listed spans represent the center-to-center distance between adjacent framing members.

<sup>6</sup> These tables are designed for dead loads. Specific conditions such as exterior installations in high wind areas require additional engineering.

<sup>7</sup> Where uplift resistance is required for suspended ceilings to resist negative forces, the architect or engineer of record shall select the method to be used.

**TABLE 2 Spans and Spacing of Cold-Rolled Channel Cross-Furring Members<sup>A, B, C</sup>**

Member Depth	Spacing, in. (mm)	Allowable Span, Main Runners or Supports Ft-in. (mm)	
		Simple Span	Two or More Spans <sup>D, E</sup>
¾ (19)	13.5 (343)	2-9 (840)	3-5 (1040)
	16 (406)	2-7 (790)	3-3 (990)
	19 (483)	2-7 (740)	3-0 (910)
	24 (610)	2-3 (690)	2-10 (860)
1½ (38)	13.5 (343)	4-6 (1370)	5-8 (1730)
	16 (406)	4-3 (1300)	5-5 (1650)
	19 (483)	4-0 (1220)	5-1 (1550)
	24 (610)	3-8 (1120)	4-9 (1450)

<sup>A</sup> Spans based on upper flange of cross-furring laterally unbraced.

<sup>B</sup> Maximum deflection limited to 1/360<sup>th</sup> of span length unbraced.

<sup>C</sup> Tabulated spans apply only to cross-furring with webs oriented vertically.

<sup>D</sup> "Two or more" spans refers to two or more continuous, equal spans.

<sup>E</sup> For the "two or more" span conditions, listed spans represent the center-to-center distance between adjacent framing members.

**TABLE 3 Types and Weights of Metal Plaster Bases and Corresponding Maximum Permissible Spacing of Wall and Ceiling Framing Members or Furring**

Type of Metal Plaster Base	Minimum Weight of Metal Plaster Base, lb/yd <sup>2</sup> (kg/m <sup>2</sup> )	Specific Installation Requirements and Maximum Permissible Spacing of Wall and Ceiling Framing Members or Furring, Center to Center, in. (mm)				
		Walls		Ceilings		
		24 (610)	16 (406)	24 (610)	16 (406)	12 (305)
Expanded Sheet Metal	2.5 (1.4)	Permitted only for self-furred lath on sheathed wall framing members or solid wall bases	Permitted	Not Permitted	Not Permitted	Permitted
	3.4 (1.8)				Permitted	
Flat Rib	2.75 (1.5)	Not Permitted	Permitted only for unsheathed wall framing members	Permitted	Permitted	
¾ in. Rib	3.4 (1.8)	Not Permitted				
	Welded Wire	1.14 (0.618)	Not Permitted	Permitted	Not Permitted	Permitted
1.95 (1.058)		Permitted		Permitted		
Woven Wire	1.4 (0.76)	Permitted only for wood wall framing members, wood furring	Permitted	Permitted only for wood and concrete ceiling framing members		
				Not Permitted	Permitted only for steel ceiling framing members	

shall be not less than 3 in. (76 mm) above the bottom edge of the framing member. (See Fig. 7.)

#### 7.4 Attachment of Hangers to Cold-rolled Channel Furring Main Runners:

7.4.1 Wire hangers shall be saddle-tied to cold-rolled channel furring main runners. (See Fig. 1.)

7.4.2 Smooth or threaded rod hangers shall be fastened to cold-rolled channel furring main runners with special attachments appropriate to the design.

7.4.3 The lower ends of strap hangers shall be bolted to cold-rolled channel furring main runners, or bent tightly around the cold-rolled channel furring main runners and carried up and above the cold-rolled channel furring main runners and bolted to the main part of the hanger. (See Fig. 3.)

#### 7.5 Installation of Cold-rolled Channel Furring Main Runners:

7.5.1 Minimum sizes and maximum spans and spacings of cold-rolled channel furring main runners for the various spans between hangers or other framing members shall be in accordance with the requirements of Table 1.

7.5.2 A clearance of not less than 1 in. (25 mm) shall be maintained between the ends of the cold-rolled channel furring main runners and the abutting masonry or the concrete walls, partitions, and columns. Where special conditions require that cold-rolled channel furring main runners let into abutting masonry or concrete construction, within such constructions maintain a clearance of not less than 1 in. (25 mm) from the ends and not less than ¼ in. (6 mm) from the tops and sides of the cold-rolled channel furring main runners.

7.5.3 A cold-rolled channel furring main runner shall be located within 6 in. (152 mm) of the paralleling walls to support the ends of the cold-rolled channel cross furring. The ends of cold-rolled channel furring main runners shall be supported by hangers located not more than 6 in. (152 mm) from the ends.

7.5.4 Where cold-rolled channel furring main runners are spliced, the ends shall be overlapped not less than 12 in. (305 mm) with flanges of cold-rolled channel furring main runners interlocked and securely tied near each end of the splice, with double loops of 0.0625 in. (1.59 mm) or double



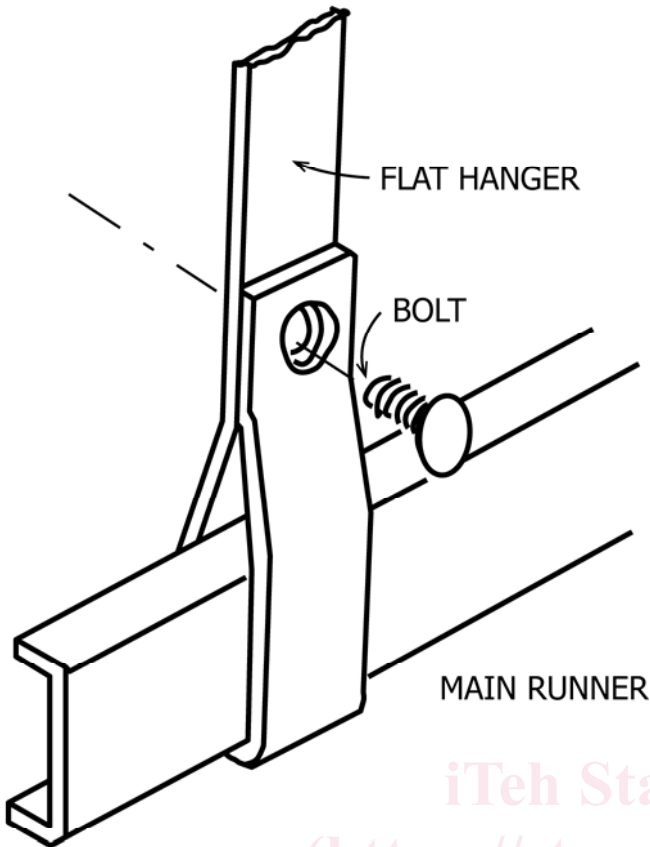

FIG. 3 Flat (Strap) Hanger Attached to Cold-rolled Channel Furring Main Runner Using Machine Bolt

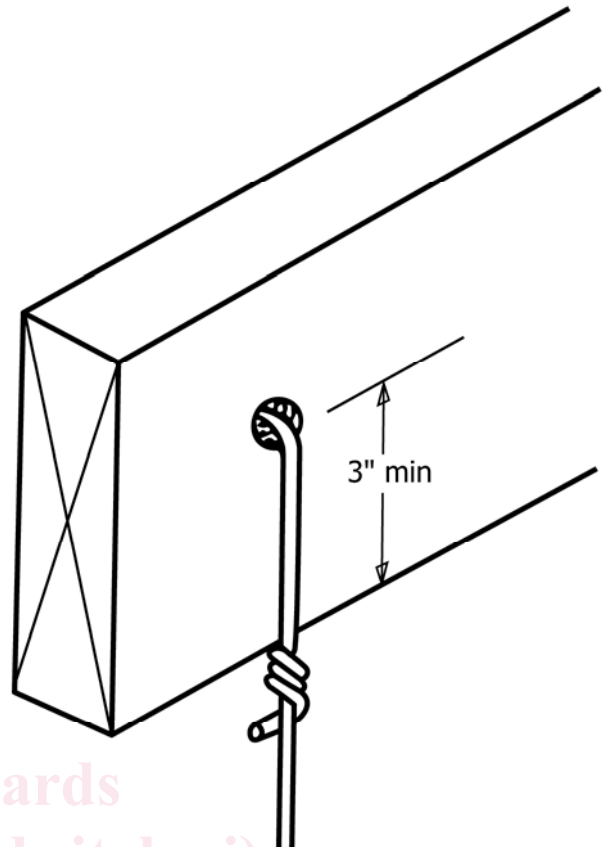

FIG. 4 Hanger Attached to Framing Member Through Drilled Hole

loops of twin strands of 0.0475-in. (1.21 mm) wire. However, when the splice occurs at an expansion joint or control joint, the cold-rolled channel furring shall be nested and loosely tied to hold together but still allow movement.

7.5.5 Hanger wires shall hang straight down. If an obstacle prevents this, a trapeze type device shall be used to allow hanger wires to hang straight.

7.6 Installation of Cold-rolled Channel Cross Furring:

7.6.1 Minimum size and maximum spans and spacings of various types of cold-rolled channel cross furring for various spans between cold-rolled channel furring main runners and framing members shall conform to the requirements of Table 2.

7.6.2 Cold-rolled channel cross furring shall be saddle-tied to cold-rolled channel furring main runners with 0.0625-in. 16 gauge (1.59 mm) wire, or a double strand of 0.0475-in. 18 gauge (1.21 mm) wire or with special galvanized clips, or equivalent attachments. (See Fig. 2.)

7.6.3 Where cold-rolled channel cross furring members are spliced, the ends shall be overlapped not less than 8 in. (203 mm), with flanges of cold-rolled channel cross furring interlocked, and securely tied near each end of the splice with double loops of 0.0625-in. (1.59 mm) 16 gauge wire or twin strands of 0.0475-in. 18 gauge (1.21 mm) wire.

7.6.4 Cold-rolled channel cross furring shall not come into contact with abutting masonry or reinforced concrete walls or partitions, except, where special conditions require that cold-

rolled channel cross furring be let into abutting masonry or concrete construction, the applicable provisions of 7.5.2 shall apply.

7.6.5 Cold-rolled channel furring main runners and cold-rolled channel cross furring shall be interrupted at expansion joints or control joints. However when the splice occurs at an expansion joint or control joint, the cold-rolled channel furring shall be nested and loosely tied to hold together but still allow movement.

7.7 Metal Furring for Walls:

7.7.1 Attachments for furring accessories shall be concrete nails driven securely into concrete or into masonry joints, power-actuated fasteners, or other devices specifically designed as spacer elements, spaced horizontally not more than 2 ft (610 mm) on centers. They shall be spaced vertically in accordance with horizontal stiffener spacing so that they project from the face of the wall in order for ties to be made.

7.7.2 Horizontal stiffeners shall be not less than 3/4 in. (19 mm) cold-rolled channel furring, spaced not to exceed 54 in. (1372 mm) on centers vertically, with the lower and upper cold-rolled channel furring not more than 6 in. (152 mm) from the ends of vertical framing members and not less than 1/4 in. (6 mm) clear from the wall face, securely tied to attachments with three loops of wire, or equivalent devices. Approved furring is not prohibited from use in this application.

7.7.3 Vertical framing members shall be not less than 3/4 in. (19 mm) cold-rolled channel furring in accordance with the requirements of Table 3. Vertical framing members shall be

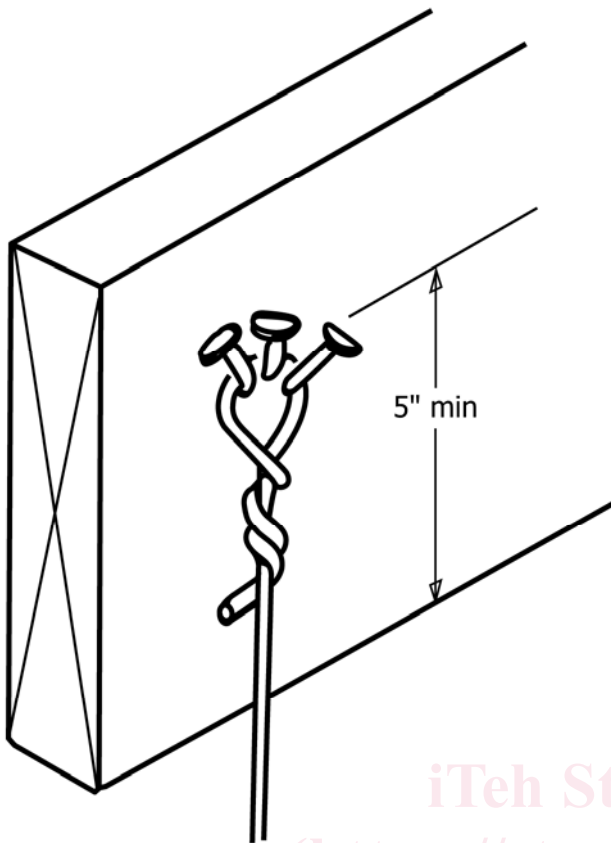

FIG. 5 Hanger Attached to Framing Member Using Nails

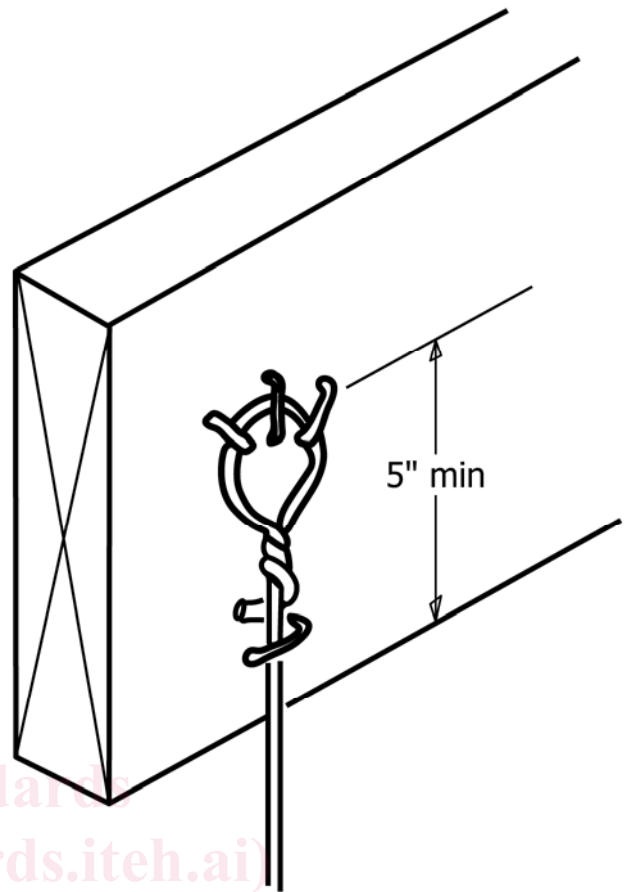

FIG. 6 Hanger Attached to Framing Member Using Staples

saddle-tied to horizontal stiffeners with three loops of 0.0475-in. (1.21 mm) wire, or equivalent devices, at each crossing, and securely anchored to the floor and ceiling constructions. Where cold-rolled channel furring is not in contact with the wall, cold-rolled channel furring braces shall be installed between horizontal stiffeners and the wall, spaced horizontally not more than 2 ft (610 mm) on centers.

7.7.4 Where the water resistive barrier has been damaged during installation of attachments, the water resistive barrier shall be repaired with the same or an alternative material, compatible with the water resistive barrier, before proceeding with the installation of the furring.

7.8 Z-furring used to support lathing and lathing accessories and its fasteners for fastening to framing members or solid bases, is a customized furring system which shall be engineered.

7.9 *Lapping of Metal Plaster Bases:*

7.9.1 Side laps of metal plaster bases shall be secured to framing members. They shall be tied between framing members with 0.0475-in. (1.21 mm) wire at intervals not more than 9 in. (229 mm).

7.9.2 Metal lath shall be lapped ½ in. (13 mm) minimum at the sides, or nest the edge ribs. Wire lath shall be lapped minimum one mesh at the sides and the ends. Lap metal lath minimum 1 in. (25 mm) at ends. Where end laps occur between the framing members, the ends of the sheets of all metal plaster bases shall be laced or wire tied with 0.0475-in. (1.21 mm) wire.

7.9.3 Where metal plaster base with an attached water resistive barrier is installed, the vertical and horizontal lap joints shall be water resistive barrier on water resistive barrier and metal plaster base on metal plaster base.

7.9.3.1 Where metal plaster base with an attached water resistive barrier is installed, the water resistive barrier shall be lapped not less than 2 in. (51 mm). shall be lapped not less than 2 in. (51 mm). On walls, the water resistive barrier shall be lapped so water will flow to the exterior. Except for weep screeds, designated drainage screeds, and drainage flashings, the water resistive barrier shall not be placed between metal plaster base and lath accessory attachment flanges. Metal plaster base to lath accessory key attachment flange contact shall be required to ensure that the metal plaster base and lath accessory key attachment flanges are mechanically locked together.

7.10 *Installation of Metal Plaster Bases:*

7.10.1 *General:*

7.10.1.1 Metal plaster bases shall be furred away from vertical framing members or solid surfaces at least ¼ in. (6 mm). Self furring lath meets furring requirements; except, furring of expanded metal lath is not required on framing members having a bearing surface of 1⅝ in. (41 mm) or less.

7.10.1.2 The spacing of framing members for the type and weight of metal plaster base shall conform to the requirements of Table 3. Metal plaster bases shall be attached to framing