



Designation: **D1742 – 06 (Reapproved 2013) D1742 – 18**

Standard Test Method for Oil Separation from Lubricating Grease During Storage¹

This standard is issued under the fixed designation D1742; the number immediately following the designation indicates the year of original adoption or, in the case of revision, the year of last revision. A number in parentheses indicates the year of last reapproval. A superscript epsilon (ϵ) indicates an editorial change since the last revision or reapproval.

This standard has been approved for use by agencies of the U.S. Department of Defense.

1. Scope-~~Scope~~*

1.1 This test method covers the determination of the tendency of a lubricating grease to separate oil during storage in both normally filled and partially filled containers.

1.2 This test method is not suitable for greases softer than NLGI No. 1 grade.

1.3 The values stated in SI units are to be regarded as standard, except for the dimensions in Fig. 2 and Fig. 5, where inch-pound units are standard.

1.4 *This standard does not purport to address all of the safety concerns, if any, associated with its use. It is the responsibility of the user of this standard to establish appropriate ~~safety~~ safety, health, and ~~health~~ environmental practices and determine the applicability of regulatory limitations prior to use. For a specific hazard statement, see 7.1.*

1.5 *This international standard was developed in accordance with internationally recognized principles on standardization established in the Decision on Principles for the Development of International Standards, Guides and Recommendations issued by the World Trade Organization Technical Barriers to Trade (TBT) Committee.*

2. Referenced Documents

2.1 ASTM Standards:²

E11 Specification for Woven Wire Test Sieve Cloth and Test Sieves

2.2 Other Standard:

NLGI Grease Consistency Classification³

3. Terminology

3.1 Definitions:

3.1.1 *lubricating grease, n*—a semi-fluid to solid product of a thickener in a liquid lubricant. <https://standards.iteh.ai/document/ASTM-D1742-18>

3.1.1.1 *Discussion*—

The dispersion of the thickener forms a two-phase system and immobilizes the liquid lubricant by surface tension and other physical forces. Other ingredients are commonly included to impart special properties.

3.1.2 *thickener, n*—in lubricating grease, a substance composed of finely-divided particles dispersed in a liquid lubricant to form the product's structure.

3.1.2.1 *Discussion*—

The thickeners can be fibers (such as various metallic soaps) or plates or spheres (such as certain non-soap thickeners), which are insoluble or, at most, only very slightly soluble in the liquid lubricant. The general requirements are that the solid particles be extremely small, uniformly dispersed, and capable of forming a relatively stable, gel-like structure with the liquid lubricant.

¹ This test method is under the jurisdiction of the ASTM Committee D02 on Petroleum Products, Liquid Fuels, and Lubricants and is the direct responsibility of Subcommittee D02.G0.03 on Physical Tests.

Current edition approved Dec. 1, 2013 April 1, 2018. Published December 2013 May 2018. Originally approved in 1960. Last previous edition approved in 2006 2013 as D1742 – 06 D1742 – 06 (2013). DOI: 10.1520/D1742-06R13.10.1520/D1742-18.

² For referenced ASTM standards, visit the ASTM website, www.astm.org, or contact ASTM Customer Service at service@astm.org. For Annual Book of ASTM Standards volume information, refer to the standard's Document Summary page on the ASTM website.

³ Available from NLGI, 4635 Wyandotte St., Kansas City, MO 64112-249 SW Noel, Suite 249, Lee's Summit, MO 64063, <http://www.nlgi.org>.

*A Summary of Changes section appears at the end of this standard



FIG. 1 Pressure Bleeding Test Cell A

3.1.3 *oil separation, n*—the appearance of a liquid fraction from an otherwise homogeneous lubricating composition.

4. Summary of Test Method

4.1 The sample of grease, supported on a ~~75- μ m~~ 75 μ m (No. 200) sieve, is subjected to ~~1.72 kPa (0.25 psi)~~ 1.72 kPa (0.25 psi) air pressure for ~~24 h at 25°C (77°F)~~ 24 h at 25 °C (77 °F). Any oil seepage that occurs drains into a beaker and is weighed.

5. Significance and Use

5.1 When a lubricating grease separates oil, the remaining composition increases in consistency. This can affect the ability of the product to function as designed.

5.2 It has been found that the results of this test correlate directly with the oil separation that occurs in ~~35-lb~~ 35 lb pails of grease during storage.

5.3 This test method is not intended to predict oil separation tendencies of the grease under dynamic conditions.

6. Apparatus

6.1 *Test Apparatus*⁴⁻⁶—The assembled apparatus consists of a tightly fitting cup and cover which contains a ~~75- μ m~~ 75 μ m (No. 200) sieve strainer for supporting the grease, a funnel for collecting separated oil, and a ~~20-mL~~ 20 mL beaker for retaining the separated oil. A fitting is provided in the cover for inlet air (~~1.72 kPa (0.25 psi)~~) (1.72 kPa (0.25 psi)) and a hole is provided in the side of the cup to prevent back pressure. Fig. 1 is a photograph of a disassembled apparatus. The details of construction are given in Fig. 2. The ~~75- μ m~~ 75 μ m (No. 200) stainless steel sieve shall conform to the requirements of Specification E11. The diameter of the ~~75- μ m~~ 75 μ m (No. 200) sieve shall be ~~104.8 mm (4 1/8 in.)~~ 104.8 mm (4 1/8 in.), completely clear with no solder showing.

⁴ The sole source of supply of Pressure Bleeding Test Cell A known to the committee at this time is Koehler Instrument Company, Inc. 1595 Sycamore Avenue, Bohemia, NY 11716. If you are aware of alternative suppliers, please provide this information to ASTM International Headquarters. Your comments will receive careful consideration at a meeting of the responsible technical committee,¹ which you may attend.

⁵ The sole source of supply of the Pressure Bleeding Test Cell B known to the committee at this time is Stanhope-Seta, London Street, Chertsey, Surrey, KT16 8AP, UK. If you are aware of alternative suppliers, please provide this information to ASTM International Headquarters. Your comments will receive careful consideration at a meeting of the responsible technical committee,¹ which you may attend.

⁶ Equipment shown in Fig. 4 and Fig. 5 is no longer available. Other appropriately designed equipment can be used.

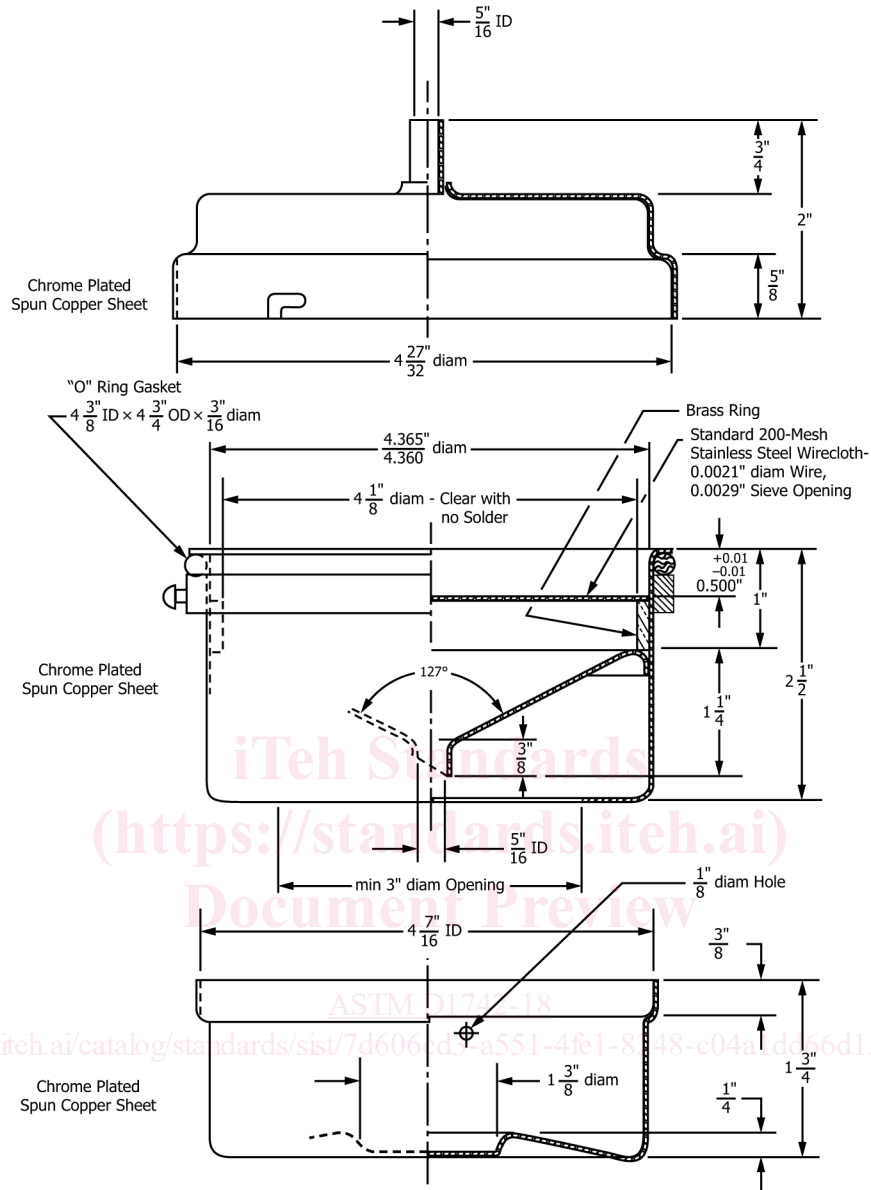

in.	mm	in.	mm	in.	mm	in.	mm
0.0021	0.053	1 5/8	41.3	0.500	12.70	47/16	112.7
0.0029	0.074	1 3/4	44.4	0.510	12.95	4 1/2	114.3
0.010	0.25	2	50.8	0.520	13.20	4 11/16	119.1
1/16	1.59	2 1/2	63.5	5/8	15.87	4 3/4	120.6
1/8	3.17	3 1/16	93.7	3/4	19.05	4 29/32	123.03
3/16	4.76	4 1/8	104.8	1	25.4	5 1/4	133.3
1/4	6.35	4.360	110.74	1 1/4	31.8	6	152.4
5/16	7.94	4.365	110.87	1 3/8	34.9	6 1/2	165.1
3/8	9.52	4 3/8	111.1	3	76.2		

FIG. 2 Detailed Drawing of Pressure Bleeding Test Cell A