



IEC 60310

Edition 5.0 2026-04

INTERNATIONAL STANDARD

REDLINE VERSION

Railway applications – ~~Traction~~ Transformers and inductors on board rolling stock

Sample Document

get full document from standards.iteh.ai



THIS PUBLICATION IS COPYRIGHT PROTECTED
Copyright © 2026 IEC, Geneva, Switzerland

All rights reserved. Unless otherwise specified, no part of this publication may be reproduced or utilized in any form or by any means, electronic or mechanical, including photocopying and microfilm, without permission in writing from either IEC or IEC's member National Committee in the country of the requester. If you have any questions about IEC copyright or have an enquiry about obtaining additional rights to this publication, please contact the address below or your local IEC member National Committee for further information.

IEC Secretariat
3, rue de Varembe
CH-1211 Geneva 20
Switzerland

Tel.: +41 22 919 02 11
info@iec.ch
www.iec.ch

About the IEC

The International Electrotechnical Commission (IEC) is the leading global organization that prepares and publishes International Standards for all electrical, electronic and related technologies.

About IEC publications

The technical content of IEC publications is kept under constant review by the IEC. Please make sure that you have the latest edition, a corrigendum or an amendment might have been published.

IEC publications search -

webstore.iec.ch/advsearchform

The advanced search enables to find IEC publications by a variety of criteria (reference number, text, technical committee,...). It also gives information on projects, replaced and withdrawn publications.

IEC Just Published - webstore.iec.ch/justpublished

Stay up to date on all new IEC publications. Just Published details all new publications released. Available online and once a month by email.

IEC Customer Service Centre - webstore.iec.ch/csc

If you wish to give us your feedback on this publication or need further assistance, please contact the Customer Service Centre: sales@iec.ch.

IEC Products & Services Portal - products.iec.ch

Discover our powerful search engine and read freely all the publications previews, graphical symbols and the glossary. With a subscription you will always have access to up to date content tailored to your needs.

Electropedia - www.electropedia.org

The world's leading online dictionary on electrotechnology, containing more than 22 500 terminological entries in English and French, with equivalent terms in 25 additional languages. Also known as the International Electrotechnical Vocabulary (IEV) online.

Warning! Make sure that you obtained this publication from an authorized distributor.

CONTENTS

FOREWORD	4
1 Scope	6
2 Normative references	6
3 Terms, definitions and abbreviated terms	8
3.1 Terms and definitions.....	8
3.1.1 General definitions	8
3.1.2 Definitions for transformers.....	10
3.1.3 Definitions for inductors	10
3.1.4 Definitions of thermal endurance	11
3.1.5 Definitions of thermal endurance calculations	11
3.2 Abbreviated terms.....	12
4 Classification.....	12
4.1 General.....	12
4.2 Classification of transformers.....	14
4.3 Classification of inductors	15
5 Service conditions	15
6 Rated current and load profile	15
6.1 Load profile.....	15
6.2 Rated current.....	15
7 Rated voltage and power of transformer windings.....	16
7.1 Rated line-side voltage	16
7.2 Rated secondary voltage	16
7.3 Rated power of transformer.....	16
8 Transformer tapplings	16
9 Cooling.....	16
9.1 Identification of transformers and inductors according to cooling method	16
9.2 Arrangement of symbols	17
9.2.1 Enclosed transformers and inductors	17
9.2.2 Non-enclosed transformers and inductors	18
9.2.3 Air cooling	18
10 Temperature limits.....	18
10.1 Classification of insulating materials	18
10.2 Temperature limits of solid insulation	18
10.3 Temperature limits for liquid.....	19
10.4 Temperature limits for other parts	20
11 Mechanical design.....	20
12 Fire protection	20
13 Rating plates	20
13.1 General.....	20
13.2 Rating plates for transformer.....	21
13.3 Rating plates for inductor	21
14 Tests	22
14.1 Categories of tests.....	22
14.1.1 General	22
14.1.2 Type tests.....	22

14.1.3	Routine tests	22
14.1.4	Investigation tests.....	22
14.2	List of checks and tests	23
14.3	Tolerances.....	26
14.3.1	Tolerances for transformer	26
14.3.2	Tolerance for inductors	27
14.4	Test items	28
14.4.1	Visual checks (type, routine test) and functional tests (optional type and routine test)	28
14.4.2	Functional tests	28
14.4.3	Mass (type and optional routine test)	28
14.4.4	Measurement of winding resistance (type and routine tests)	28
14.4.5	Measurement of voltage ratio, polarities and vector groups (type and routine tests)	29
14.4.6	Measurement of impedance voltages or short-circuit impedances (type and routine tests)	30
14.4.7	Measurement of inductance (type and routine tests)	30
14.4.8	Measurement of no-load primary current and losses (type and routine tests)	34
14.4.9	Measurement of fundamental load losses (type and routine tests)	34
14.4.10	Determination of losses	35
14.4.11	Temperature-rise test (type test)	36
14.4.12	Insulation resistance test (optional type and routine test)	41
14.4.13	Dielectric test (type and routine tests)	42
14.4.14	Partial discharge test (type or optional routine test for dry type, investigation test for immersed type)	50
14.4.15	Short-circuit withstand test (optional type test)	52
14.4.16	Shock and vibration test (optional type test)	55
14.4.17	Vibration test with current flowing (investigation test)	57
14.4.18	Voltage Transmission Ratio (VTR) (optional type test)	57
14.4.19	Noise measurement (type test)	58
14.4.20	Leakage magnetic flux density measurement (optional type test)	58
14.4.21	Electrical frequency response analysis (FRA) (investigation test)	58
14.4.22	Inrush current measurement (optional type test)	58
Annex A (informative)	List of items for which an agreement between purchaser and manufacturer is needed or for which further information or specifications shall be given by the purchaser or by the manufacturer List of items subject to agreement between purchaser and manufacturer, and list of information from purchaser or manufacturer	60
Annex B (informative)	Thermal ageing and insulation lifetime	72
Annex C (informative)	Example of thermal endurance calculation to demonstrate the suitability of an insulation system for a specified application	76
Annex D (informative)	Wet dielectric tests for dry-type transformers and inductors	80
Annex E (informative)	Load profiles	83
Annex F (informative)	Background of reference temperature and dielectric test voltage in IEC 60310	84
Bibliography	86
Figure 1	– Traction transformer with auxiliary windings fed by AC power supply system	13
Figure 2	– Traction transformer without auxiliary windings fed by AC power supply system	13

Figure 3 – DC locomotive typical circuit diagram	14
Figure 4 – Energy storage system typical circuit diagram	14
Figure 5 – Examples of set up for induced voltage withstanding tests	46
Figure 6 – Examples of set up for separate source voltage withstanding tests	46
Figure 7 – Examples of impulse test connections for traction, inductor and auxiliary transformers	47
Figure 8 – Partial discharge test: voltage versus time	51
Figure 9 – Configurations for VTR test	57
Figure 10 – Example of test circuit	59
Table 1 – Letter symbols for cooling method	17
Table 2 – Order of symbols	17
Table 3 – Temperature limits of solid insulation	19
Table 4 – Temperature limits for liquid	19
Table 5 – List of checks and tests to be made on traction transformers
Table 5 – List of checks and tests to be made on transformers or inductors	25
Table 6 – Tolerances for transformer	26
Table 7 – Tolerances for inductors	27
Table 8 – Reference temperatures	28
Table 9 – Dielectric test voltage	43
Table 10 – Test method of voltage between terminals withstand test	49
Table 10 – List of checks and tests to be made on inductors
Table 11 – Partial discharge measurements	51
Table C.1 – Temperature limits and expected lifetime for a dry-type transformer or inductor (examples)	76
Table C.2 – Load cycle histogram	77
Table C.3 – Temperature histogram	77
Table C.4 – Temperature rise test results	78
Table C.5 – Thermal endurance calculation	78
Table C.6 – Equivalent current and temperatures	79
Table F.1 – Reference temperatures in IEC 60310:2016	84
Table F.2 – Dielectric test voltage in IEC 60310:2016	85

INTERNATIONAL ELECTROTECHNICAL COMMISSION

Railway applications -
~~Traction~~ Transformers and inductors on board rolling stock

FOREWORD

- 1) The International Electrotechnical Commission (IEC) is a worldwide organization for standardization comprising all national electrotechnical committees (IEC National Committees). The object of IEC is to promote international co-operation on all questions concerning standardization in the electrical and electronic fields. To this end and in addition to other activities, IEC publishes International Standards, Technical Specifications, Technical Reports, Publicly Available Specifications (PAS) and Guides (hereafter referred to as "IEC Publication(s)"). Their preparation is entrusted to technical committees; any IEC National Committee interested in the subject dealt with may participate in this preparatory work. International, governmental and non-governmental organizations liaising with the IEC also participate in this preparation. IEC collaborates closely with the International Organization for Standardization (ISO) in accordance with conditions determined by agreement between the two organizations.
- 2) The formal decisions or agreements of IEC on technical matters express, as nearly as possible, an international consensus of opinion on the relevant subjects since each technical committee has representation from all interested IEC National Committees.
- 3) IEC Publications have the form of recommendations for international use and are accepted by IEC National Committees in that sense. While all reasonable efforts are made to ensure that the technical content of IEC Publications is accurate, IEC cannot be held responsible for the way in which they are used or for any misinterpretation by any end user.
- 4) In order to promote international uniformity, IEC National Committees undertake to apply IEC Publications transparently to the maximum extent possible in their national and regional publications. Any divergence between any IEC Publication and the corresponding national or regional publication shall be clearly indicated in the latter.
- 5) IEC itself does not provide any attestation of conformity. Independent certification bodies provide conformity assessment services and, in some areas, access to IEC marks of conformity. IEC is not responsible for any services carried out by independent certification bodies.
- 6) All users should ensure that they have the latest edition of this publication.
- 7) No liability shall attach to IEC or its directors, employees, servants or agents including individual experts and members of its technical committees and IEC National Committees for any personal injury, property damage or other damage of any nature whatsoever, whether direct or indirect, or for costs (including legal fees) and expenses arising out of the publication, use of, or reliance upon, this IEC Publication or any other IEC Publications.
- 8) Attention is drawn to the Normative references cited in this publication. Use of the referenced publications is indispensable for the correct application of this publication.
- 9) IEC draws attention to the possibility that the implementation of this document may involve the use of (a) patent(s). IEC takes no position concerning the evidence, validity or applicability of any claimed patent rights in respect thereof. As of the date of publication of this document, IEC had not received notice of (a) patent(s), which may be required to implement this document. However, implementers are cautioned that this may not represent the latest information, which may be obtained from the patent database available at <https://patents.iec.ch>. IEC shall not be held responsible for identifying any or all such patent rights.

This redline version of the official IEC Standard allows the user to identify the changes made to the previous edition IEC 60310:2016. A vertical bar appears in the margin wherever a change has been made. Additions are in green text, deletions are in strikethrough red text.

IEC 60310 has been prepared by IEC technical committee 9: Electrical equipment and systems for railways. It is an International Standard.

This fifth edition cancels and replaces the fourth edition published in 2016. This edition constitutes a technical revision.

This edition includes the following significant technical changes with respect to the previous edition:

- a) typical circuits for transformer and inductors are added;
- b) letter symbols for cooling methods are added;
- c) dielectric test table is modified;
- d) subclauses for the tests of transformers and inductors are restructured;
- e) temperature test for dry type transformer and dry type inductors are separated in different subclauses;
- f) requirements for shock and vibration tests are updated according to IEC 61373:20—.

The text of this International Standard is based on the following documents:

Draft	Report on voting
9/3296/FDIS	9/3322/RVD

Full information on the voting for its approval can be found in the report on voting indicated in the above table.

The language used for the development of this International Standard is English.

This document was drafted in accordance with ISO/IEC Directives, Part 2, and developed in accordance with ISO/IEC Directives, Part 1 and ISO/IEC Directives, IEC Supplement, available at www.iec.ch/members_experts/refdocs. The main document types developed by IEC are described in greater detail at www.iec.ch/publications.

The committee has decided that the contents of this document will remain unchanged until the stability date indicated on the IEC website under webstore.iec.ch in the data related to the specific document. At this date, the document will be

- reconfirmed,
- withdrawn, or
- revised.

1 Scope

~~This International Standard applies to traction and auxiliary power transformers installed on board rolling stock and to the various types of power inductors inserted in the traction and auxiliary circuits of rolling stock, of dry or liquid-immersed design.~~

~~NOTE—The requirements of IEC 60076 (all parts) are applicable to transformers and inductors where they do not conflict with this standard, or with the specialized IEC publications dealing with traction applications.~~

~~This standard can also be applied, after agreement between purchaser and manufacturer, to the traction transformers of three-phase a.c. line-side powered vehicles and to the transformers inserted in the single-phase or poly-phase auxiliary circuits of vehicles, except instrument transformers and transformers of a rated output below 1 kVA single-phase or 5 kVA poly-phase.~~

This document specifies the terms and definitions, classification, service conditions, characteristics and test methods for transformers and inductors on board rolling stock.

This document is applicable to traction and auxiliary power transformers installed on board rolling stock and to the various types of power inductors inserted in the traction and auxiliary circuits of rolling stock, of dry or liquid-immersed design.

This document is also applicable to the traction transformers of three-phase AC line-side powered vehicles and to the transformers inserted in the single-phase or polyphase auxiliary circuits of vehicles, after agreement between purchaser and manufacturer.

This document does not apply to instrument transformers, transformers of a rated output below 1 kVA single-phase or 5 kVA poly-phase, and inductors of a rated output below 1 kVAR single-phase or 5 kVAR poly-phase on board rolling stock.

This document does not cover accessories such as tap changers, resistors, heat exchangers, fans, etc., intended for mounting on transformers or inductors, which are tested separately according to the relevant rules.

NOTE Items requiring agreement between the delivery parties and items of supplementary information and specification particulars to be provided by the ordering party or manufacturer are given in Annex A.

2 Normative references

The following documents are referred to in the text in such a way that some or all of their content constitutes requirements of this document. For dated references, only the edition cited applies. For undated references, the latest edition of the referenced document (including any amendments) applies.

~~IEC 60050-811, International Electrotechnical Vocabulary (IEV) — Chapter 811: Electric traction~~

~~IEC 60060-1, High-voltage test techniques — Part 1: General definitions and test requirements~~

~~IEC 60060-2, High-voltage test techniques — Part 2: Measuring systems~~

IEC 60076-1:2011, *Power transformers - Part 1: General*

IEC 60076-2, *Power transformers - Part 2: Temperature rise for liquid-immersed transformers*

IEC 60076-3, *Power transformers - Part 3: Insulation levels, dielectric tests and external clearances in air*

~~IEC 60076-4, Power transformers—Part 4: Guide to the lightning impulse and switching impulse testing—Power transformers and reactors~~

IEC 60076-5, Power transformers - Part 5: Ability to withstand short circuit

IEC 60076-6:2007, Power transformers - Part 6: Reactors

~~IEC 60076-7, Power transformers—Part 7: Loading guide for oil-immersed power transformers~~

IEC 60076-10, Power transformers - Part 10: Determination of sound levels

~~IEC 60076-11, Power transformers—Part 11: Dry-type transformers~~

IEC 60076-12:2008, Power transformers - Part 12: Loading guide for dry-type transformers

~~IEC 60076-14, Power transformers—Part 14: Liquid immersed power transformers using high-temperature insulation materials~~

IEC 60076-18, Power transformers - Part 18: Measurement of frequency response

~~IEC 60077-1, Railway applications—Electric equipment for rolling stock—Part 1: General service conditions and general rules~~

~~IEC 60085, Electrical insulation—Thermal evaluation and designation~~

~~IEC 60270, High-voltage test techniques—Partial discharge measurements~~

IEC 60296, Fluids for electrotechnical applications --~~Unused~~ Mineral insulating oils for ~~transformers and switchgear~~ electrical equipment

IEC 60836, Specifications for unused silicone insulating liquids for electrotechnical purposes

IEC 60850, Railway applications - Supply voltages of traction systems

IEC 61039, Classification of insulating liquids

IEC 61099, Insulating liquids - Specifications for unused synthetic organic esters for electrical purposes

IEC 61373:2010~~20~~—, Railway applications - Rolling stock equipment - Shock and vibration tests¹

IEC 61378-1:2011, Converter transformers - Part 1: Transformers for industrial applications

IEC 62497-1:2010, Railway applications - Insulation coordination - Part 1: Basic requirements - Clearances and creepage distances for all electrical and electronic equipment

IEC 62497-1:2010/AMD1:2013

IEC 62498-1, Railway applications - Environmental conditions for equipment - Part 1: Equipment on board rolling stock

¹ Under preparation. Stage at the time of publication: IEC FDIS 61373:2024.

ISO 3746, *Acoustics - Determination of sound power levels and sound energy levels of noise sources using sound pressure - Survey method using an enveloping measurement surface over a reflecting plane*

ISO 9614-1, *Acoustics - Determination of sound power levels of noise sources using sound intensity - Part 1: Measurement at discrete points*

ISO 9614-2, *Acoustics - Determination of sound power levels of noise sources using sound intensity - Part 2: Measurement by scanning*

3 Terms, definitions and abbreviated terms

For the purposes of this document, the terms and definitions given in IEC 60076-1, IEC 62497-1 and ~~IEC 60050-811 together with~~ the following apply.

ISO and IEC maintain terminology databases for use in standardization at the following addresses:

- IEC Electropedia: available at <https://www.electropedia.org/>
- ISO Online browsing platform: available at <https://www.iso.org/obp>

NOTE 1 When the term "transformer" is used alone, it applies to both traction and auxiliary transformers.

NOTE 2 The term "transformer(s)/inductor(s)" appears in clauses applicable to both transformers and inductors to avoid duplication of text.

NOTE 3 The term "inductor" is used in this document with the same meaning as the term "reactor" mentioned in IEC 60050-421, IEC 60050-811 and IEC 60076-6.

3.1 Terms and definitions

3.1.1 General definitions

3.1.1.1

traction transformer

transformer intended to supply the traction circuits, and optionally other equipment

3.1.1.2

auxiliary transformer

<on-board power supply system> transformer intended to supply electrical equipment except traction circuits

Note 1 to entry: In the energy storage system, the transformer that supplies power to the traction circuit(s) is called a traction transformer, and that supplying power to the electrical equipment except traction circuit(s) is called an auxiliary transformer.

3.1.1.3

inductor

two-terminal device characterized essentially by its inductance

[SOURCE: IEC 60050-151:2001, 151-13-25, modified – The notes to entry have been omitted.]

3.1.1.4

load profile

<component> component output power or current/~~power~~ versus time under specified conditions including voltage, rectifier, configuration, harmonic content, etc.

Note 1 to entry: Efficiency for the transformer is agreed between the manufacturer and purchaser.

3.1.1.5**short time emergency loading**

unusually heavy loading of a transient nature (less than one time constant of the transformer) occurring during degraded mode, such as a loss of one traction converter, etc.

[SOURCE: IEC 60076-12:2008, 3.2, modified – "(less than one time constant of the coil)" replaced with "(less than one time constant of the transformer)", "the occurrence of one or more unlikely events which seriously disturb normal system loading" replaced with "occurring during degraded mode"]

3.1.1.6**cooling medium**

~~cooling~~ medium used to extract the heat out of the transformer/ or inductor e.g. air, water, oil, heat sink, etc.

3.1.1.7**rated insulation voltage**

U_{Nm}

RMS withstand voltage value assigned by the manufacturer to the equipment or a part of it, characterising the specified permanent (over 5 min) withstand capability of its insulation

Note 1 to entry: U_{Nm} is a voltage between a live part of equipment and earth or another live part. For rolling stock, earth refers to the car body.

Note 2 to entry: For circuits, systems and sub-systems in railway applications, this definition is preferred to "highest voltage for equipment" which is widely used in international standards.

Note 3 to entry: U_{Nm} is higher than or equal to the working voltage. As a consequence, for circuits directly connected to the contact line, U_{Nm} is equal to or higher than U_{max1} as specified in IEC 60850. For circuits connected to electronic converter U_{Nm} is higher than or equal to the DC link voltage.

Note 4 to entry: U_{Nm} is not necessarily equal to the rated voltage which is primarily related to functional performance.

[SOURCE: IEC 62497-1:2010, 3.4.4, modified – Addition of the second sentence in Note 3 to entry.]

3.1.1.8**nominal voltage**

U_n

suitable approximate voltage used to designate or identify a given supply system

3.1.1.9**rated voltage**

U_r

value of voltage assigned for a specific operating condition

3.1.1.10**rated impulse voltage**

U_{Ni}

impulse voltage value, characterizing the specified withstand capability of its insulation against transient over-voltages

3.1.1.11**test voltage**

U_a

RMS value derived from U_{Nm} used for separate source voltage, induced voltage, voltage between terminals withstand, depending on test carried out

3.1.1.12 recurring peak voltage

U_{mT}

U_{mG}

maximum peak value of periodic excursions of the voltage waveform between terminals (U_{mT}) or between terminals and ground (U_{mG})

3.1.2 Definitions for transformers

3.1.2.1 voltage transmission ratio

VTR

ratio between the secondary voltage and the primary voltage when a specified impulse or AC square voltage is applied on the primary

Note 1 to entry: The VTR is expressed as a percentage of this applied voltage.

3.1.2.2 impedance voltage

voltage applied to reach the rated current in short-circuit

Note 1 to entry: This is expressed as a percentage of this applied voltage to the rated voltage at reference temperature.

Note 2 to entry: When expressed as a percentage or per unit, this is equal to the short circuit impedance referred in IEC 60076-1:2011, 3.7.1.

3.1.2.3 tolerance

permitted deviation between the declared value of a quantity and the measured value

[SOURCE: IEC 60050-411:2007, 411-36-19]

3.1.3 Definitions for inductors

NOTE Values of inductance for inductors are related to the different classes of utilization and are defined as follows, with the understanding that they include an indication of the nature and value of the current used in their measurement.

3.1.3.1 AC inductance

inductance derived from the measurement of the alternating current carried by the inductor when it is supplied by a sinusoidal alternating voltage of specified value and frequency

[SOURCE: IEC 60050-811:2017, 811-26-36]

3.1.3.2 differential inductance

inductance defined from the derivative of the linked flux as a function of current (equal to the slope of the magnetic characteristic)

Note 1 to entry: It is derived from the transient record of instantaneous voltage and current in the inductor or from the measurement of the variation of magnetic flux.

3.1.3.3 incremental inductance

inductance seen by the AC current of a particular value and frequency superimposed on a DC current through the inductor

Note 1 to entry: ~~It should be mentioned that~~ The ripple factor of a pulsating current, expressed as a percentage, is conventionally defined by the formula:

$$\frac{I_{\max} - I_{\min}}{I_{\max} + I_{\min}} \times 100$$

where I_{\max} and I_{\min} respectively represent the maximum and minimum values of the current wave.

Note 2 to entry: It is derived from a record of the terminal voltage.

3.1.4 Definitions of thermal endurance

3.1.4.1 thermal endurance

time taken for the deterioration of a selected property (electrical, mechanical, etc.) to reach a specified end-point at a given temperature

Note 1 to entry: An insulation material mainly ensures the electric performance (dielectric strength) of the conductor insulation, while the impregnation, casting, sealing, coating, etc., materials mainly ensure the mechanical performance of the windings (water tightness, resistance to thermal cycling and shock, resistance to vibration or shocks, thermal conduction, etc.).

Note 2 to entry: An end-point of 50 % of the initial value of the property is used (unless otherwise specified).

3.1.4.2 temperature index

TI

numerical value of the temperature (in degrees Celsius) derived from the thermal endurance relationship at a time of 20 000 h (unless otherwise specified)

Note 1 to entry: TI is referring to the RTE (Relative Thermal Endurance) or ATE (Assessed Thermal Endurance) indexes used in IEC 60216-5.

3.1.4.3 halving interval

HIC

numerical value of the temperature interval (in Kelvins) which expresses the halving of the time to end-point taken at the temperature equal to TI

[SOURCE: IEC 60050-212:2010, 212-12-13, modified – "corresponding to the temperature index or the relative temperature index" has been replaced with "equal to TI".]

3.1.5 Definitions of thermal endurance calculations

NOTE As far as thermal endurance calculations are concerned, IEC 60076-12 provides an explanation of ageing fundamentals and the means to estimate ageing rate and consumption of lifetime of the transformer or inductor insulation as a function of operating temperature, time and loading. The hot-spot temperature is used to estimate the number of hours of lifetime consumed during a particular time period of loading.

3.1.5.1 thermal endurance in continuous operation

ECO

value derived from the simplified equation of the Arrhenius plot (based on TI and HIC) for a given hotspot temperature θ_{HS} (°C)

$$ECO(h) = 20\,000 \times 2^{\frac{TI - \theta_{\text{HS}}}{HIC}}$$

Note 1 to entry: This simplified formula is very convenient to understand the concept of TI and HIC. However, this formula yields slightly pessimistic results compared to the exact formula.

Note 2 to entry: Whenever possible, the exact Arrhenius formula derived from the endurance graph (constants A and B) is used, where $E(h)$ is the thermal endurance and $T_{\text{HS}}(\text{K}) = \theta_{\text{HS}}(\text{°C}) + 273,15$ is the thermodynamic (absolute) hot-spot temperature:

$$\log E(h) = \log A + \frac{B}{T_{HS}(K)}$$

which represents the thermal endurance graph, or

$$E(h) = a \times \exp\left(\frac{b}{T_{HS}}\right)$$

which expresses directly the thermal endurance value.

3.1.5.2

actual operating time

AOT

actual time (in hours) the insulating system will operate at the given hotspot temperature

3.1.5.3

consumed endurance potential

CEP

ratio of actual operating time by consumed endurance potential for a given hotspot temperature

$$CEP(\%) = \frac{AOT}{ECO} \times 100$$

3.2 Abbreviated terms

For the purposes of this document, the following abbreviations apply:

AC	alternating current
AOT	actual operating time
ATE	assessed thermal endurance
CEP	consumed endurance potential
DC	direct current
ECO	thermal endurance in continuous operation
EIM	electrical insulating material
EIS	electrical insulating system
FEA	finite element analysis
FRA	frequency response analysis
HIC	halving interval
HV	high voltage
RMS	root mean square
RTE	relative thermal endurance
TI	thermal index
VTR	voltage transmission ratio

4 Classification

4.1 General

The traction transformer and auxiliary transformer could be integrated, i.e. the traction transformers could have several secondary windings, such as traction windings, auxiliary windings. Traction windings supply power to traction circuits. Auxiliary windings supply power to auxiliary equipment.

NOTE In this document, the load side windings that feed the traction circuit or the auxiliary circuit used for other purposes or both are collectively called "secondary windings".

The typical circuits are described in this document to show the functions of each component. Figure 1 shows the typical circuit diagram for traction transformer with auxiliary windings, and Figure 2 shows that of separated traction and auxiliary transformers, while the traction transformer is fed by AC power supply system, and the auxiliary transformer is fed by an inverter connected to DC intermediate link. Figure 3 shows the typical circuit diagram for auxiliary transformer fed by DC power supply system. Figure 4 shows the typical circuit diagram for traction transformer (Medium Frequency Transformer) fed by Energy Storage System such as fuel cell battery system.

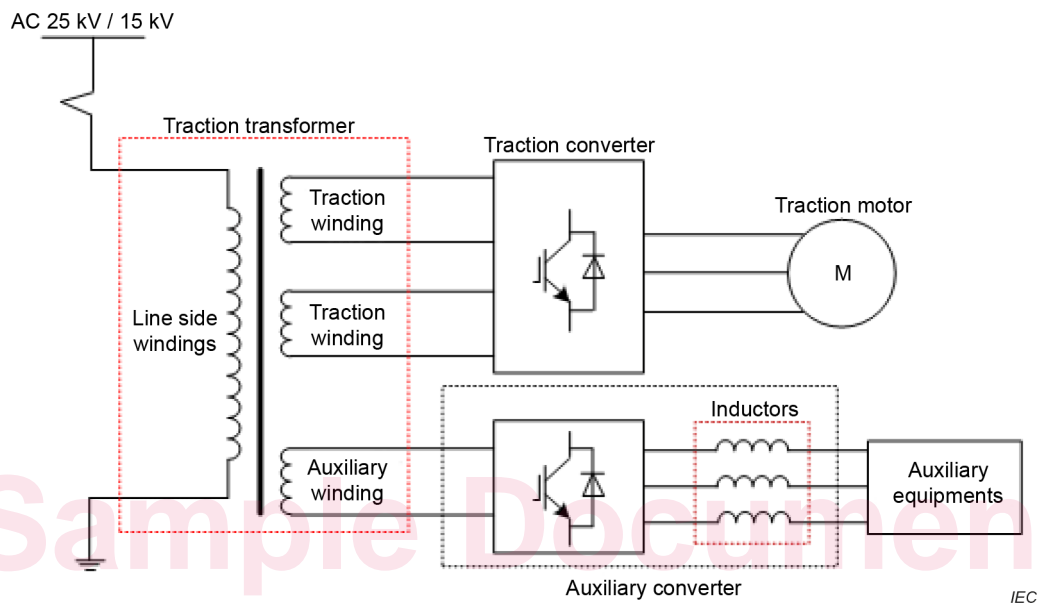

Figure 1 – Traction transformer with auxiliary windings fed by AC power supply system

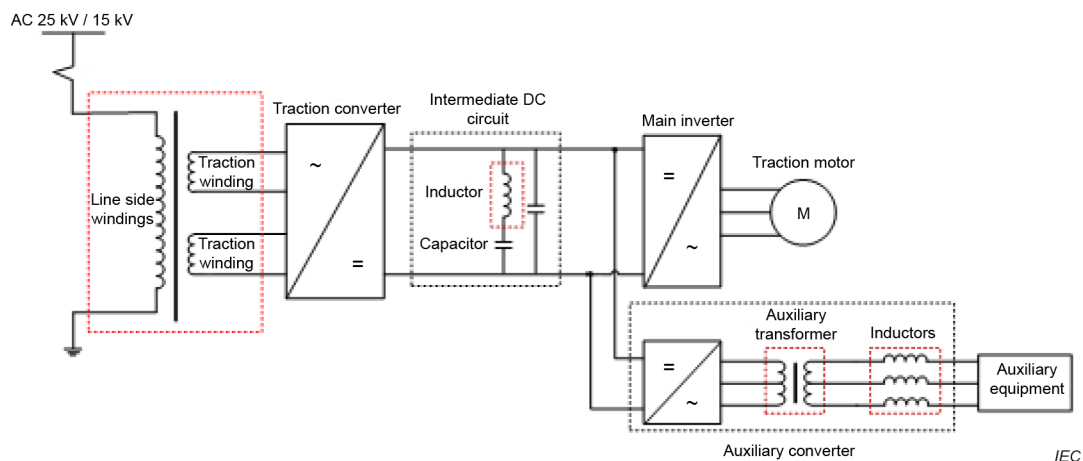

Figure 2 – Traction transformer without auxiliary windings fed by AC power supply system