

INTERNATIONAL STANDARD

REDLINE VERSION

INTERNATIONAL SPECIAL COMMITTEE ON RADIO INTERFERENCE

HORIZONTAL PUBLICATION

GENERIC EMC STANDARD

**Electromagnetic compatibility (EMC) -
Part 6-3: Generic standards - Emission standard for equipment in residential
environments locations**

get full document from standards.iteh.ai



THIS PUBLICATION IS COPYRIGHT PROTECTED
Copyright © 2026 IEC, Geneva, Switzerland

All rights reserved. Unless otherwise specified, no part of this publication may be reproduced or utilized in any form or by any means, electronic or mechanical, including photocopying and microfilm, without permission in writing from either IEC or IEC's member National Committee in the country of the requester. If you have any questions about IEC copyright or have an enquiry about obtaining additional rights to this publication, please contact the address below or your local IEC member National Committee for further information.

IEC Secretariat
3, rue de Varembe
CH-1211 Geneva 20
Switzerland

Tel.: +41 22 919 02 11
info@iec.ch
www.iec.ch

About the IEC

The International Electrotechnical Commission (IEC) is the leading global organization that prepares and publishes International Standards for all electrical, electronic and related technologies.

About IEC publications

The technical content of IEC publications is kept under constant review by the IEC. Please make sure that you have the latest edition, a corrigendum or an amendment might have been published.

IEC publications search -

webstore.iec.ch/advsearchform

The advanced search enables to find IEC publications by a variety of criteria (reference number, text, technical committee,...). It also gives information on projects, replaced and withdrawn publications.

IEC Just Published - webstore.iec.ch/justpublished

Stay up to date on all new IEC publications. Just Published details all new publications released. Available online and once a month by email.

IEC Customer Service Centre - webstore.iec.ch/csc

If you wish to give us your feedback on this publication or need further assistance, please contact the Customer Service Centre: sales@iec.ch.

IEC Products & Services Portal - products.iec.ch

Discover our powerful search engine and read freely all the publications previews, graphical symbols and the glossary. With a subscription you will always have access to up to date content tailored to your needs.

Electropedia - www.electropedia.org

The world's leading online dictionary on electrotechnology, containing more than 22 500 terminological entries in English and French, with equivalent terms in 25 additional languages. Also known as the International Electrotechnical Vocabulary (IEV) online.

Warning! Make sure that you obtained this publication from an authorized distributor.

CONTENTS

FOREWORD.....	5
INTRODUCTION.....	7
1 Scope.....	8
2 Normative references	8
3 Terms, definitions and abbreviated terms	10
3.1 Terms and definitions.....	10
3.2 Abbreviated terms.....	10
4 Classification of equipment.....	15
5 Measurements and conditions during testing	17
6 Documentation for the user.....	18
7 Applicability	19
8 Requirements	19
9 Measurement uncertainty	19
10 Compliance with this document	19
11 Emission test details.....	20
11.1 General.....	20
11.2 Setting test frequency ranges	26
11.3 Additional requirements for devices with a radio function	27
Annex A (informative) Classification of equipment and mapping to the immunity standards.....	29
Annex B (normative) Testing of DC powered systems	30
Annex C (informative) Rationale for alternative test levels requirements at the DC power port	32
C.1 General.....	32
C.2 Necessity of alternative test methods in generic standards	32
C.3 Limit justification in table clause 5.2.....	32
C.3.1 Proportional relation approach.....	32
C.3.2 Current-to-voltage conversion approach	33
C.3.3 Setting the final limit	34
Annex D (informative) Alternative average detectors.....	35
D.1 General.....	35
D.2 Changes implemented in CISPR 16-1-1:2019	35
D.3 Conclusion.....	36
Annex E (informative) Background information on the normative limits in the frequency range 9 kHz to 150 kHz	37
E.1 Derivation of the normative limits	37
E.2 Radio protection analysis	39
E.2.1 General	39
E.2.2 Radio protection analysis for common mode disturbance injections	39
E.2.3 Radio protection analysis for differential mode disturbance injections	46
Annex F (informative) Spectral density of non-intentional emissions (NIE) in the frequency range 9 kHz to 150 kHz	53
F.1 Introduction of Integral Voltage Levels (IVL) for the limitation of the spectral density of NIE	53
F.2 Recommended maximum IVL for NIE.....	54

F.3	Rationale for the recommendation of additional limitations on the spectral density of non-intentional emissions	54
F.3.1	Rationale	54
F.3.2	Relationship between MCE performances and Integral Voltage Levels	55
Annex G (informative)	Rationale for radiated magnetic field emissions requirements	60
Annex H (informative)	Possible limits for radiated magnetic field emissions for EUT with the potential to produce disturbing electromagnetic fields	61
Annex I (informative)	The conversion factor for magnetic emissions limits below 30 MHz	63
I.1	General.....	63
I.2	Considerations.....	65
I.3	Summary	68
Annex J (informative)	Magnetic field emission limit correction based upon power	70
J.1	General.....	70
J.2	Limits.....	70
Bibliography	71
Figure 1	– Example of ports	13
Figure 2	– Basic WPT configuration	15
Figure 3	– Illustration of F_{TX} and F_X	28
Figure 4	– Excluded band	28
Figure C.1	– Equivalent circuit of test set up for measurement of disturbance voltages	33
Figure D.1	– Typical filter responses.....	35
Figure E.1	– Example of a V-AMN.....	38
Figure E.2	– Worst case common mode radiator for residential locations	39
Figure E.3	– Simulation results for the coupling factor for both field types.....	41
Figure E.4	– Worst case disturbance field strength at 10 m distance	42
Figure E.5	– Proposed field strengths limits compared to protection needs of radio applications	46
Figure E.6	– Worst-case differential mode radiator for residential locations	47
Figure E.7	– Simulation results for the coupling factor for differently sized loops	48
Figure E.8	– Properties of a V-AMN	49
Figure E.9	– Proposed field strengths limits compared to protection needs of radio applications	52
Figure F.1	– Example of a multi-carrier MCE spectrum	55
Figure F.2	– Laboratory test setup for the evaluation of the relationship between MCE performances and Integral Voltage Levels	56
Figure F.3	– Example of broadband noise produced by the NIE source used in the test	57
Figure F.4	– Spectral noise from device A, lower disturbing effect	58
Figure F.5	– Spectral noise from device B, higher disturbing effect	58
Figure I.1	– Example measurement of a real EUT at measurement distances (d) of 3 m and 10 m	64
Figure I.2	– Qualitative magnetic field lines in xz-plane of a horizontal loop and vertical dipole over infinite perfectly conducting ground.....	64
Figure I.3	– The six fundamental field source configurations	65
Figure I.4	– Absolute field strengths generated by 60 cm loops in all orientations at different distances	66

Figure I.5 – Absolute field strengths generated by 80 cm dipoles in all orientations at different distances	66
Figure I.6 – Conversion factors for dominant coupling.....	67
Figure I.7 – Derivation of the final conversion factor using dominant coupling for EUTs described in I.1	68
Figure I.8 – Conversion factor from a distance of 3 m to 10 m, in the frequency range 150 kHz to 30 MHz (CF _{3 m to 10 m})	69
Table 1 – Test arrangements of EUT	18
Table 2 – Required highest frequency for radiated measurement	22
Table 32 – Requirements for radiated electric field emissions, enclosure port.....	22
Table 3 – Requirements for radiated magnetic field emissions, enclosure port.....	23
Table 4 – Requirements for conducted emissions, low-voltage AC mains port.....	24
Table 5 – Requirements for conducted emissions, DC power port.....	25
Table 6 – Requirements for conducted emissions, other wired ports	26
Table 7 – Required highest frequency for radiated electric field emission measurements for EUT containing at least one active radio transmitter that is transmitting.....	27
Table 8 – Required highest frequency for radiated electric field emission measurements for EUT not containing at least one active radio transmitter that is transmitting.....	27
Table A.1 – Examples of emission and immunity requirements against product type and intended use	29
Table B.1 – Conducted emission requirements of DC powered equipment	30
Table B.2 – Conditional requirements for the start frequency of test at DC power ports for tests defined in table clause B1.4 to B1.7	31
Table C.1 – DC power port, terminal disturbance voltage limits for class B GCPCs, measured on a test site, proportion relation approach.....	33
Table C.2 – DC power port, terminal disturbance voltage limits for class B GCPCs, measured on a test site, current-to-voltage conversion approach.....	34
Table D.1 – Updated tolerances.....	35
Table E.1 – Simulation results for the coupling factor for both field types.....	40
Table E.2 – Worst case disturbance field strength at 10 m distance	42
Table E.3 – Probability factors and respective rationales	43
Table E.4 – Calculations of the required field strength limit.....	45
Table E.5 – Calculations of the required field strength limit.....	48
Table E.6 – Conversion from voltage limit to current limit for injection.....	49
Table E.7 – Disturbance field strength calculation for 20 cm and 50 cm loops.....	50
Table E.8 – Disturbance field strength calculation for 100 cm loop.....	51
Table F.1 – Recommended maximum Integral Voltage Levels.....	54
Table F.2 – Recommended maximum Integral Voltage Levels for equipment covered by footnote ^a to Table 4.....	54
Table F.3 – Correlation between MCE’s noise assessment and Integral Voltage Levels computed in the MCE’s operating frequency ranges.....	57
Table F.4 – Correlation between IVLs and MCE communication performance	58
Table H.1 – Proposed limits for radiated magnetic field emissions, enclosure port	62

Table I.1 – Conversion factor from a distance of 3 m to 10 m in the frequency range 150 kHz to 30 MHz (CF _{3 m to 10 m})	69
Table J.1 – Proposed reduction to the limits	70

Sample Document

get full document from standards.iteh.ai

INTERNATIONAL ELECTROTECHNICAL COMMISSION

**Electromagnetic compatibility (EMC) -
Part 6-3: Generic standards -
Emission standard for equipment in residential ~~environments~~ locations**

FOREWORD

- 1) The International Electrotechnical Commission (IEC) is a worldwide organization for standardization comprising all national electrotechnical committees (IEC National Committees). The object of IEC is to promote international co-operation on all questions concerning standardization in the electrical and electronic fields. To this end and in addition to other activities, IEC publishes International Standards, Technical Specifications, Technical Reports, Publicly Available Specifications (PAS) and Guides (hereafter referred to as "IEC Publication(s)"). Their preparation is entrusted to technical committees; any IEC National Committee interested in the subject dealt with may participate in this preparatory work. International, governmental and non-governmental organizations liaising with the IEC also participate in this preparation. IEC collaborates closely with the International Organization for Standardization (ISO) in accordance with conditions determined by agreement between the two organizations.
- 2) The formal decisions or agreements of IEC on technical matters express, as nearly as possible, an international consensus of opinion on the relevant subjects since each technical committee has representation from all interested IEC National Committees.
- 3) IEC Publications have the form of recommendations for international use and are accepted by IEC National Committees in that sense. While all reasonable efforts are made to ensure that the technical content of IEC Publications is accurate, IEC cannot be held responsible for the way in which they are used or for any misinterpretation by any end user.
- 4) In order to promote international uniformity, IEC National Committees undertake to apply IEC Publications transparently to the maximum extent possible in their national and regional publications. Any divergence between any IEC Publication and the corresponding national or regional publication shall be clearly indicated in the latter.
- 5) IEC itself does not provide any attestation of conformity. Independent certification bodies provide conformity assessment services and, in some areas, access to IEC marks of conformity. IEC is not responsible for any services carried out by independent certification bodies.
- 6) All users should ensure that they have the latest edition of this publication.
- 7) No liability shall attach to IEC or its directors, employees, servants or agents including individual experts and members of its technical committees and IEC National Committees for any personal injury, property damage or other damage of any nature whatsoever, whether direct or indirect, or for costs (including legal fees) and expenses arising out of the publication, use of, or reliance upon, this IEC Publication or any other IEC Publications.
- 8) Attention is drawn to the Normative references cited in this publication. Use of the referenced publications is indispensable for the correct application of this publication.
- 9) IEC draws attention to the possibility that the implementation of this document may involve the use of (a) patent(s). IEC takes no position concerning the evidence, validity or applicability of any claimed patent rights in respect thereof. As of the date of publication of this document, IEC had not received notice of (a) patent(s), which may be required to implement this document. However, implementers are cautioned that this may not represent the latest information, which may be obtained from the patent database available at <https://patents.iec.ch>. IEC shall not be held responsible for identifying any or all such patent rights.

This redline version of the official IEC Standard allows the user to identify the changes made to the previous edition IEC 61000-6-3:2020. A vertical bar appears in the margin wherever a change has been made. Additions are in green text, deletions are in strikethrough red text.

IEC 61000-6-3 has been prepared by CISPR subcommittee H: Limits for the protection of radio services. It is an International Standard.

This fourth edition cancels and replaces the third edition published in 2020. This edition constitutes a technical revision.

This edition includes the following significant technical changes with respect to the previous edition:

- a) the addition of magnetic field emission requirements, including the measurement of WPT function;
- b) the extension of low-voltage AC mains power requirements to cover the range 9 kHz to 150 kHz;
- c) products with a radio function have been added to the scope;
- d) limits in a FAR for rack mounted equipment have been added.

The text of this document is based on the following documents:

Draft	Report on voting
CIS/H/547/FDIS	CIS/H/557/RVD

Full information on the voting for the approval of this document can be found in the report on voting indicated in the above table.

The language used for the development of this International Standard is English.

This document has been drafted in accordance with the ISO/IEC Directives, Part 2, and developed in accordance with ISO/IEC Directives, Part 1 and ISO/IEC Directives, IEC Supplement, available at www.iec.ch/members_experts/refdocs. The main document types developed by IEC are described in greater detail at www.iec.ch/publications.

A list of all parts in the IEC 61000 series, published under the general title *Electromagnetic compatibility (EMC)*, can be found on the IEC website.

The committee has decided that the contents of this document will remain unchanged until the stability date indicated on the IEC website under webstore.iec.ch in the data related to the specific document. At this date, the document will be

- reconfirmed,
- withdrawn, or
- revised.

INTRODUCTION

IEC 61000 is published in separate parts according to the following structure:

Part 1: General

General considerations (introduction, fundamental principles)
Definitions, terminology

Part 2: Environment

Description of the environment
Classification of the environment
Compatibility levels

Part 3: Limits

Emission limits
Immunity limits (insofar as they do not fall under the responsibility of the product committees)

Part 4: Testing and measurement techniques

Measurement techniques
Testing techniques

Part 5: Installation and mitigation guidelines

Installation guidelines
Mitigation methods and devices

Part 6: Generic standards

Part 9: Miscellaneous

Each part is further subdivided into several parts published either as International Standards, technical reports or technical ~~reports~~/specifications, ~~some of which have already been~~. These are published as sections. Others will be published with the part number followed by a dash and a second number identifying the subdivision (example: IEC 61000-6-1).

1 Scope

This generic EMC emission standard is applicable only if no relevant dedicated product or product family EMC emission standard has been published.

This part of IEC 61000 for emission requirements applies to electrical and electronic equipment intended for use at residential (see 3.1.21) locations. This part of IEC 61000 also applies to electrical and electronic equipment intended for use at other locations that do not fall within the scope of IEC 61000-6-8 or IEC 61000-6-4.

The intention is that all equipment used in the residential, commercial and light-industrial ~~environments~~ locations are covered by IEC 61000-6-3 or IEC 61000-6-8. If there is any doubt the requirements in IEC 61000-6-3 apply.

~~The conducted and radiated emission requirements in the frequency range up to 400 GHz are considered essential and have been selected to provide an adequate level of protection of radio reception in the defined electromagnetic environment.~~ Equipment that have a radio function (3.1.20) are included in the scope of this document. However, the emission requirements in this document are not intended to be applicable to the intentional transmissions from these radio transmitters, their harmonics and their out of band emissions.

Not all disturbance phenomena have been included for testing purposes but only those considered relevant for the equipment intended to operate within the locations included within this document.

~~The emission requirements in this document are not intended to be applicable to the intentional transmissions and their harmonics from a radio transmitter as defined by the ITU.~~

The objectives of this document are:

- a) to establish requirements that provide an adequate level of protection of radio reception in the frequency range 9 kHz to 400 GHz;
- b) to establish requirements that provide an adequate level of protection against conducted and radiated electromagnetic disturbances emitted by equipment in the scope of this document;
- c) to support the reproducibility of measurement and the repeatability of results.

~~NOTE 1 – Safety considerations are not covered by this document.~~

~~NOTE 2 1~~ In special cases, situations will arise where the levels specified in this document will not offer adequate protection; for example, where a sensitive receiver is used in close proximity to an equipment. In these instances, special mitigation measures can be employed.

~~NOTE 32~~ Disturbances generated in fault conditions of equipment are not covered by this document.

~~NOTE 43 As~~ The requirements in this document are more stringent or equivalent to the requirements specified in IEC 61000-6-4 and IEC 61000-6-8; ~~equipment fulfilling the requirements of this document comply with the requirements of IEC 61000-6-4 and IEC 61000-6-8.~~

2 Normative references

The following documents are referred to in the text in such a way that some or all of their content constitutes requirements of this document. For dated references, only the edition cited applies. For undated references, the latest edition of the referenced document (including any amendments) applies.

IEC 61000-3-2:2018, *Electromagnetic compatibility (EMC) - Part 3-2: Limits - Limits for harmonic current emissions (equipment input current ≤ 16 A per phase)*

IEC 61000-3-2:2018/AMD1:2020

IEC 61000-3-2:2018/AMD2:2024

IEC 61000-3-3:2013, *Electromagnetic compatibility (EMC) - Part 3-3: Limits - Limitation of voltage changes, voltage fluctuations and flicker in public low-voltage supply systems, for equipment with rated current ≤ 16 A per phase and not subject to conditional connection*

IEC 61000-3-3:2013/AMD1:2017

IEC 61000-3-3:2013/AMD2:2021

IEC 61000-3-11:2017, *Electromagnetic compatibility (EMC) - Part 3-11: Limits - Limitation of voltage changes, voltage fluctuations and flicker in public low-voltage supply systems - Equipment with rated current ≤ 75 A and subject to conditional connection*

IEC 61000-3-12:2011, *Electromagnetic compatibility (EMC) - Part 3-12: Limits - Limits for harmonic currents produced by equipment connected to public low-voltage systems with input current > 16 A and ≤ 75 A per phase*

IEC 61000-3-12:2011/AMD1:2021

IEC 61000-4-20:2010, *Electromagnetic compatibility (EMC) - Part 4-20: Testing and measurement techniques - Emission and immunity testing in transverse electromagnetic (TEM) waveguides*

CISPR 14-1:2016, *Electromagnetic compatibility - Requirements for household appliances, electric tools and similar apparatus - Part 1: Emission*

CISPR 16-1-1:2019, *Specification for radio disturbance and immunity measuring apparatus and methods - Part 1-1: Radio disturbance and immunity measuring apparatus - Measuring apparatus*

CISPR 16-1-1:2010, *Specification for radio disturbance and immunity measuring apparatus and methods - Part 1-1: Radio disturbance and immunity measuring apparatus - Measuring apparatus¹*

CISPR 16-1-1:2010/AMD1:2010

CISPR 16-1-1:2010/AMD2:2014

CISPR 16-1-2:2014, *Specification for radio disturbance and immunity measuring apparatus and methods - Part 1-2: Radio disturbance and immunity measuring apparatus - Coupling devices for conducted disturbance measurements*

CISPR 16-1-2:2014/AMD1:2017

CISPR 16-1-4:2019, *Specification for radio disturbance and immunity measuring apparatus and methods - Part 1-4: Radio disturbance and immunity measuring apparatus - Antennas and test sites for radiated disturbance measurements*

CISPR 16-1-4:2019/AMD1:2020

CISPR 16-1-4:2019/AMD2:2023

CISPR 16-1-5:2014, *Specification for radio disturbance and immunity measuring apparatus and methods - Part 1-5: Radio disturbance and immunity measuring apparatus - Antenna calibration sites and reference test sites for 5 MHz to 18 GHz*

CISPR 16-1-5:2014/AMD1:2016

CISPR 16-1-6:2014, *Specification for radio disturbance and immunity measuring apparatus and methods - Part 1-6: Radio disturbance and immunity measuring apparatus - EMC antenna calibration*

CISPR 16-1-6:2014/AMD1:2017

CISPR 16-1-6:2014/AMD2:2022

¹ This version has been superseded.

CISPR 16-2-1:2014, *Specification for radio disturbance and immunity measuring apparatus and methods - Part 2-1: Methods of measurement of disturbances and immunity - Conducted disturbance measurements*

CISPR 16-2-1:2014/AMD1:2017

CISPR 16-2-3:2016, *Specification for radio disturbance and immunity measuring apparatus and methods - Part 2-3: Methods of measurement of disturbances and immunity - Radiated disturbance measurements*

CISPR 16-2-3:2016/AMD1:2019

CISPR 16-2-3:2016/AMD2:2023

CISPR 16-4-2:2011, *Specification for radio disturbance and immunity measuring apparatus and methods - Part 4-2: Uncertainties, statistics and limit modelling - Measurement instrumentation uncertainty*

CISPR 16-4-2:2011/AMD1:2014

CISPR 16-4-2:2011/AMD2:2018

CISPR 32:2015, *Electromagnetic compatibility of multimedia equipment - Emission requirements*

CISPR 32:2015/AMD1:2019

3 Terms, definitions and abbreviated terms

3.1 Terms and definitions

For the purposes of this document, the following terms and definitions apply.

ISO and IEC maintain terminological databases for use in standardization at the following addresses:

- IEC Electropedia: available at <http://www.electropedia.org/>
- ISO Online browsing platform: available at <http://www.iso.org/obp>

3.1.1

adjustable speed electric power drive function

power drive system function that provides adjustable speed AC or DC motor drives and can convert input voltages (line-to-line) to other voltages

3.1.2

antenna port

port, other than a broadcast receiver tuner port (3.1.4), for connection of an antenna used for intentional transmission ~~and/or~~, reception of radiated RF energy

3.1.3

associated equipment

AE

equipment needed to exercise, monitor or to exercise ~~and/or~~ monitor the operation of the EUT

Note 1 to entry: The AE can be either local (within the measurement or test area) or remote.

3.1.4

broadcast receiver tuner port

port intended for the reception of a modulated RF signal carrying terrestrial, satellite ~~and/or~~ cable transmissions of audio ~~and/or~~ broadcast, video broadcast and similar services

Note 1 to entry: This port ~~may~~ can be connected to an antenna, a cable distribution system, a VCR or similar device.

3.1.5**DC distribution network**

local supply network in the infrastructure of a site or building intended for use by one or more different types of equipment and providing power independent of the public mains network

Note 1 to entry: Connection to a remote local battery is not regarded as a DC distribution network, if such a link comprises only power supply for a single piece of equipment.

3.1.6**DC power port**

port used to connect to a low-voltage DC power generating system, energy storage or DC distribution network to power the equipment

Note 1 to entry: See Annex B.

3.1.7**enclosure port**

physical boundary of the equipment which electromagnetic fields ~~may~~ can radiate through or impinge on

3.1.8**highest internal frequency**
 F_x

highest fundamental frequency generated or used within the EUT, or the highest frequency at which it operates, whichever is the greater

Note 1 to entry: This includes fundamental frequencies which are solely used within an integrated circuit.

Note 2 to entry: This excludes the frequencies generated or used intentionally by a radio function (3.1.20).

3.1.9**low-voltage**
~~LV~~

voltage having a value below a conventionally adopted limit

Note 1 to entry: For the distribution of AC electric power, the upper limit is generally accepted to be 1 000 V. For the distribution of DC electric power, the upper limit is generally accepted to be 1 500 V.

3.1.10**low-voltage AC mains port**

port used to connect to the low-voltage (3.1.9) AC mains supply network to power the equipment

Note 1 to entry: Equipment with a DC power port is considered low-voltage AC mains powered if it is powered from an AC/DC power converter.

Note 2 to entry: The low-voltage AC mains supply could be public or non-public.

3.1.11**necessary bandwidth**

for a given class of emission, the width of the frequency band which is just sufficient to ensure the transmission of information at the rate and with the quality required under specified conditions

[SOURCE: ITU Radio Regulations (2020), 1.152]

3.1.12**optical fibre port**

port at which an optical fibre is connected to an equipment

3.1.13

out-of-band emission

emission on a frequency or frequencies immediately outside the necessary bandwidth which results from the modulation process, but excluding spurious emissions

Note 1 to entry: In terms of this definition, “immediately outside” means “adjacent to”.

[SOURCE: ITU Radio Regulations (2020), 1.144, modified – Addition of Note 1 to entry.]

3.1.14

plasma screen

display that uses small cells containing plasma, an ionized gas that responds to electric fields to create light

3.1.15

port

physical interface of the specified equipment with the external electromagnetic environment

Note 1 to entry: See Figure 1.

Note 2 to entry: Examples of ‘Other wired port’ shown in Figure 1 are specified in Table 6.

Sample Document

get full document from standards.iteh.ai

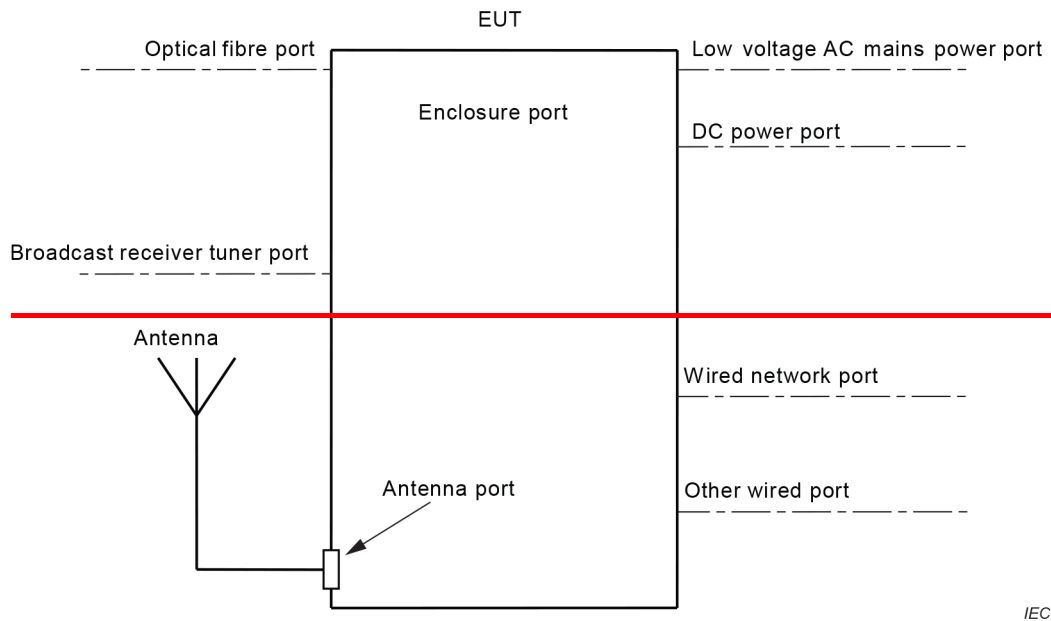

IEC.

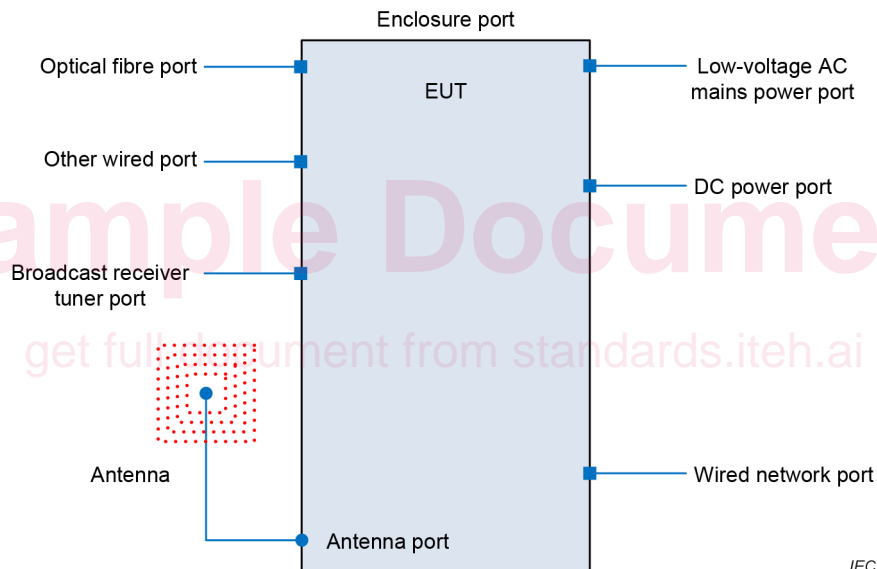

IEC

Figure 1 – Example of ports

3.1.16**power port**

port for the connection of the equipment to its primary electrical power supply

3.1.17**primary function**

any function of an EUT considered essential for the user or for the majority of users

Note 1 to entry: An EUT can have more than one primary function. For example, the primary functions of a basic television set include broadcast reception, audio reproduction and display.

3.1.18**primary WPT port**

port through which power is transferred wirelessly to equipment with one or more secondary WPT ports