

INTERNATIONAL STANDARD

**Railway applications - Electronic power converters for fixed installations -
Part 2-2: DC Traction applications - Controlled converters**

Sample Document

get full document from standards.iteh.ai



THIS PUBLICATION IS COPYRIGHT PROTECTED
Copyright © 2026 IEC, Geneva, Switzerland

All rights reserved. Unless otherwise specified, no part of this publication may be reproduced or utilized in any form or by any means, electronic or mechanical, including photocopying and microfilm, without permission in writing from either IEC or IEC's member National Committee in the country of the requester. If you have any questions about IEC copyright or have an enquiry about obtaining additional rights to this publication, please contact the address below or your local IEC member National Committee for further information.

IEC Secretariat
3, rue de Varembe
CH-1211 Geneva 20
Switzerland

Tel.: +41 22 919 02 11
info@iec.ch
www.iec.ch

About the IEC

The International Electrotechnical Commission (IEC) is the leading global organization that prepares and publishes International Standards for all electrical, electronic and related technologies.

About IEC publications

The technical content of IEC publications is kept under constant review by the IEC. Please make sure that you have the latest edition, a corrigendum or an amendment might have been published.

IEC publications search -

webstore.iec.ch/advsearchform

The advanced search enables to find IEC publications by a variety of criteria (reference number, text, technical committee, ...). It also gives information on projects, replaced and withdrawn publications.

IEC Just Published - webstore.iec.ch/justpublished

Stay up to date on all new IEC publications. Just Published details all new publications released. Available online and once a month by email.

IEC Customer Service Centre - webstore.iec.ch/csc

If you wish to give us your feedback on this publication or need further assistance, please contact the Customer Service Centre: sales@iec.ch.

IEC Products & Services Portal - products.iec.ch

Discover our powerful search engine and read freely all the publications previews, graphical symbols and the glossary. With a subscription you will always have access to up to date content tailored to your needs.

Electropedia - www.electropedia.org

The world's leading online dictionary on electrotechnology, containing more than 22 500 terminological entries in English and French, with equivalent terms in 25 additional languages. Also known as the International Electrotechnical Vocabulary (IEV) online.

Warning! Make sure that you obtained this publication from an authorized distributor.

CONTENTS

FOREWORD	3
INTRODUCTION	5
1 Scope	6
2 Normative references	6
3 Terms, definitions, symbols, and abbreviated terms	7
3.1 Terms and definitions	7
3.1.1 Semiconductor devices and combinations	7
3.1.2 Line-commutated converters	7
3.1.3 Self-commutated converters	8
3.2 Graphical symbols	8
3.3 Abbreviated terms	9
4 System configurations	9
4.1 General	9
4.2 Purpose of converters	10
4.2.1 AC/DC converters	10
4.2.2 DC converters	14
4.3 Basic characteristic of converters	15
4.3.1 General	15
4.3.2 Line-commutated converters	15
4.3.3 Self-commutated converters	16
4.3.4 Special considerations for combinations of AC/DC converters	18
4.4 Interface to 3AC power network	19
4.5 Interface to DC electric traction power supply system	20
5 Design and integration	20
5.1 System integration and coordination requirements	20
5.2 Load requirements	20
5.3 Data to be defined by the user's specification	20
5.4 Mechanical requirements defined by the user's specification	21
5.5 Data to be indicated by the manufacturer:	21
6 Performance requirements	22
6.1 General	22
6.2 Protection	22
6.3 Short-time withstand current	22
6.4 Rating plate	23
6.5 Main circuit terminals marking	24
6.6 Losses	24
7 Tests	24
7.1 General	24
7.2 Test specifications	25
7.2.1 Visual inspection	25
7.2.2 Test of accessory and auxiliary components	25
7.2.3 Insulation test	26
7.2.4 Operational sequence test	26
7.2.5 Checking of protective functions	26
7.2.6 Control function test	26
7.2.7 Light load functional tests	27

7.2.8	Load test.....	27
7.2.9	Inherent voltage drop	27
7.2.10	Temperature rise test	27
7.2.11	Short-time withstand current test	28
7.2.12	Power loss determination.....	29
7.2.13	Audible sound.....	29
7.2.14	EMC.....	29
7.2.15	Harmonic measurements	30
7.2.16	Power factor measurement	30
7.2.17	Mechanical tests	30
Annex A (informative) Power flow control strategies.....		31
A.1	General	31
A.2	Examples for DC side coordination of current versus voltage characteristics.....	31
Annex B (informative) Calculation factors.....		42
Annex C (informative) Test circuits for load tests		43
C.1	General	43
C.2	Test circuits	43
Bibliography.....		45
Figure 1 – General arrangement of AC/DC converters.....		10
Figure 2 – Connection with separate transformers		12
Figure 3 – Connection with combined transformer.....		12
Figure 4 – Connection with combined transformer with taps.....		13
Figure 5 – Converter with reversible valve device assembly.....		13
Figure 6 – Common system configuration of stationary ESS.....		14
Figure 7 – Configurations of DC converters		14
Figure A.1 – Thyristor rectifier		31
Figure A.2 – DC converter		32
Figure A.3 – Diode rectifier with a DC converter		33
Figure A.4 – Diode rectifier and self-commutated inverter		34
Figure A.5 – Diode rectifier and thyristor inverter		35
Figure A.6 – Diode rectifier and thyristor inverter		36
Figure A.7 – Diode rectifier and thyristor inverter		37
Figure A.8 – Diode rectifier and thyristor inverter		38
Figure A.9 – Thyristor rectifier and thyristor inverter.....		39
Figure A.10 – Self-commutated converter/inverter.....		40
Figure A.11 – Self-commutated converter/inverter.....		41
Figure C.1 – Test of a controlled rectifier or inverter.....		43
Figure C.2 – Test of a reversible converter.....		43
Table 1 – Graphical symbols.....		8
Table 2 – Rectifiers, inverters and combinations		11
Table 3 – Summary of tests		25
Table B.1 – Voltage factors		42

INTERNATIONAL ELECTROTECHNICAL COMMISSION

**Railway applications -
Electronic power converters for fixed installations -
Part 2-2: DC Traction applications - Controlled converters**

FOREWORD

- 1) The International Electrotechnical Commission (IEC) is a worldwide organization for standardization comprising all national electrotechnical committees (IEC National Committees). The object of IEC is to promote international co-operation on all questions concerning standardization in the electrical and electronic fields. To this end and in addition to other activities, IEC publishes International Standards, Technical Specifications, Technical Reports, Publicly Available Specifications (PAS) and Guides (hereafter referred to as "IEC Publication(s)"). Their preparation is entrusted to technical committees; any IEC National Committee interested in the subject dealt with may participate in this preparatory work. International, governmental and non-governmental organizations liaising with the IEC also participate in this preparation. IEC collaborates closely with the International Organization for Standardization (ISO) in accordance with conditions determined by agreement between the two organizations.
- 2) The formal decisions or agreements of IEC on technical matters express, as nearly as possible, an international consensus of opinion on the relevant subjects since each technical committee has representation from all interested IEC National Committees.
- 3) IEC Publications have the form of recommendations for international use and are accepted by IEC National Committees in that sense. While all reasonable efforts are made to ensure that the technical content of IEC Publications is accurate, IEC cannot be held responsible for the way in which they are used or for any misinterpretation by any end user.
- 4) In order to promote international uniformity, IEC National Committees undertake to apply IEC Publications transparently to the maximum extent possible in their national and regional publications. Any divergence between any IEC Publication and the corresponding national or regional publication shall be clearly indicated in the latter.
- 5) IEC itself does not provide any attestation of conformity. Independent certification bodies provide conformity assessment services and, in some areas, access to IEC marks of conformity. IEC is not responsible for any services carried out by independent certification bodies.
- 6) All users should ensure that they have the latest edition of this publication.
- 7) No liability shall attach to IEC or its directors, employees, servants or agents including individual experts and members of its technical committees and IEC National Committees for any personal injury, property damage or other damage of any nature whatsoever, whether direct or indirect, or for costs (including legal fees) and expenses arising out of the publication, use of, or reliance upon, this IEC Publication or any other IEC Publications.
- 8) Attention is drawn to the Normative references cited in this publication. Use of the referenced publications is indispensable for the correct application of this publication.
- 9) IEC draws attention to the possibility that the implementation of this document may involve the use of (a) patent(s). IEC takes no position concerning the evidence, validity or applicability of any claimed patent rights in respect thereof. As of the date of publication of this document, IEC had not received notice of (a) patent(s), which may be required to implement this document. However, implementers are cautioned that this may not represent the latest information, which may be obtained from the patent database available at <https://patents.iec.ch>. IEC shall not be held responsible for identifying any or all such patent rights.

IEC 62590-2-2 has been prepared by IEC technical committee 9: Electrical equipment and systems for railways. It is an International Standard.

This first edition partially cancels and replaces IEC 62589 and IEC 62590. This edition constitutes a technical revision.

The text of this International Standard is based on the following documents:

Draft	Report on voting
9/3312/FDIS	9/3328/RVD

Full information on the voting for its approval can be found in the report on voting indicated in the above table.

The language used for the development of this International Standard is English.

This document was drafted in accordance with ISO/IEC Directives, Part 2, and developed in accordance with ISO/IEC Directives, Part 1 and ISO/IEC Directives, IEC Supplement, available at www.iec.ch/members_experts/refdocs. The main document types developed by IEC are described in greater detail at www.iec.ch/publications.

A list of all parts in the IEC 62590 series, published under the general title *Railway applications - Electronic power converters for fixed installations*, can be found on the IEC website.

The committee has decided that the contents of this document will remain unchanged until the stability date indicated on the IEC website under webstore.iec.ch in the data related to the specific document. At this date, the document will be

- reconfirmed,
- withdrawn, or
- revised.

Sample Document

get full document from standards.iteh.ai

INTRODUCTION

Semiconductor converters for traction power supply differ from other electronic power converters for industrial use due to special electrical service conditions and due to the large range of load variation and the particular characteristics of the load.

Controlled rectifiers supply a DC traction network from a three-phase power network using controllable semiconductor valves. Inverters allow the recuperation of power from a DC traction network into a three-phase power network. Reversible converters combine the functions of a rectifier and an inverter.

DC converters are self-commutated converters for connecting the DC traction network to other DC networks or storage devices.

Sample Document

get full document from standards.iteh.ai

1 Scope

This part of IEC 62590 describes functions and working principles, specifies requirements, interfaces, and test methods for controlled converters for DC electric traction power supply systems:

- AC/DC converters:
 - rectifiers,
 - inverters,
 - combinations.
- DC converters.

The purpose of the converters can be a power connection to other power networks or energy storages.

The common characteristic of this equipment is the possibility to influence the power flow in the DC electric traction power supply system. The converters can be:

- line-commutated;
- self-commutated.

This document applies to fixed installations of the following electric traction systems:

- railway networks,
- metropolitan transport networks including metros, tramways, trolleybuses and fully automated transport systems, magnetic levitated transport systems, and electric road systems.

2 Normative references

The following documents are referred to in the text in such a way that some or all of their content constitutes requirements of this document. For dated references, only the edition cited applies. For undated references, the latest edition of the referenced document (including any amendments) applies.

IEC 60071-1, *Insulation co-ordination - Part 1: Definitions, principles and rules*

IEC 60529, *Degrees of protection provided by enclosures (IP code)*

IEC 62590-1:2025, *Railway applications - Electronic power converters for fixed installations - Part 1: General requirements*

IEC 62695, *Railway applications - Fixed installations - Traction transformers*

IEC 62236-5, *Railway applications - Electromagnetic compatibility - Part 5: Emission and immunity of fixed power supply installations and apparatus*

3 Terms, definitions, symbols, and abbreviated terms

For the purposes of this document, the terms and definitions given in IEC 62590-1 and the following apply.

ISO and IEC maintain terminology databases for use in standardization at the following addresses:

- IEC Electropedia: available at <https://www.electropedia.org/>
- ISO Online browsing platform: available at <https://www.iso.org/obp>

3.1 Terms and definitions

3.1.1 Semiconductor devices and combinations

3.1.1.1 rated current

I_{Nd}

<of a controlled converter> value of a DC current a controlled converter is designed for, referring to the DC electric traction power supply system

Note 1 to entry: All rated values of the components are derived from this value.

Note 2 to entry: A converter can have a rated continuous current and rated currents in conjunction with a duty class.

3.1.1.2 rated DC power

<of a controlled converter> rated current multiplied with nominal DC voltage

Note 1 to entry: This value refers to DC electric traction power supply system side.

3.1.1.3 reversible converter

converter in which the direction of the power flow is reversible

[SOURCE IEC 60050-551:1998, 551-12-37, modified – Figure 1 has been omitted.]

3.1.2 Line-commutated converters

3.1.2.1 trigger delay angle

time expressed in angular measure by which the trigger pulse is delayed with respect to the reference instant in the case of phase control

Note 1 to entry: With line, machine or load commutated converters the reference instant is the zero crossing instant of the commutating voltage. With AC controllers it is the zero crossing instant of the supply voltage. For AC controllers with inductive loads the trigger delay angle is the sum of the phase shift and the current delay angle.

[SOURCE: IEC 60050-551:1998, 551-16-33, modified – In the definition, “the” has been deleted.]

3.1.2.2 commutation failure

failure to commute the current from a conducting arm to the succeeding arm

[SOURCE: IEC 60050-551:1998, 551-16-59, modified – In the definition, “a” has been deleted]

3.1.3 Self-commutated converters

3.1.3.1

switched valve device

controllable valve device which can be turned on and off by a control signal

[SOURCE: IEC 60050-551:1998, 551-14-08, modified – In the definition, “a” has been deleted, “may” has been replaced with “can”.]

3.1.3.2

free-wheeling diode

diode parallel to a switched valve device in reverse direction fulfilling the purpose of a free-wheeling arm

3.1.3.3

buck converter

direct DC converter providing an output voltage which is lower than the input voltage



[SOURCE: IEC 60050-551:1998, 551-12-33]

3.2 Graphical symbols

Table 1 lists all symbols used in this document. These symbols are based on symbols registered in IEC 60617.

Table 1 – Graphical symbols

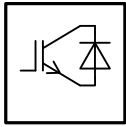
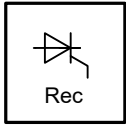
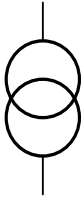
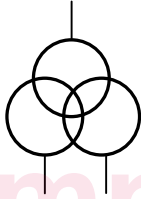
Symbol	Explanation
	<p>AC/DC converter with optional indication of power flow direction</p> <p>SOURCE: IEC 60617-S00213:2001-07; IEC 60617-S01402:2001-09; IEC 60617-S01403:2001-09 IEC 60617-S00099:2001-07; IEC 60617-S00100:2001-07; IEC 60617-S01407:2001-10.</p>
	<p>DC converter</p> <p>SOURCE: IEC 60617-S00213:2001-07; IEC 60617-S01402:2001-09.</p>
	<p>DC converter with isolation between 2 electrical circuits</p> <p>SOURCE: IEC 60617-S00213:2001-07; IEC 60617-S01402:2001-09; IEC 60617-S01407:2001-10</p>
	<p>diode rectifier (valve device) assembly</p> <p>SOURCE: IEC 60617-S00641:2001-07;</p>

Symbol	Explanation
	IGBT converter (valve device) assembly SOURCE: IEC 60617-S00616:2001-07; IEC 60617 S00621:2001-07; IEC 60617-S00624:2001-07; IEC 60617-S00641:2001-07.
	thyristor converter (valve device) assembly SOURCE: IEC 60617-S00654:2001-07.
	Transformer with two windings SOURCE: IEC 60617-S00841:2001-07.
	Transformer with three windings SOURCE: IEC 60617-S00844:2001-07.
	Group of connections SOURCE: IEC 60617-S00002:2001-07.

3.3 Abbreviated terms

3AC	three phase alternating current
AC	alternating current
ACTB	apparatus for connecting the ESU to the DC bus
DC	direct current
ESS	energy storage system
ESU	energy storage unit
IGBT	insulated gate bipolar transistor
U_a	power frequency test voltage for power frequency withstand voltage test
U_{dN}	nominal DC voltage
U_{v0}	no load transformer voltage, valve side

4 System configurations

4.1 General

The main purpose of controlled electronic power converters for DC electric traction power supply systems is to establish an intended power flow. The power can flow from a 3AC power network to the DC electric traction system or vice versa. This can also be a bidirectional power flow to energy storages or other equipment using regenerated power.

4.2 Purpose of converters

4.2.1 AC/DC converters

4.2.1.1 General

The AC/DC converters connect a 3AC power network with a DC electric traction power supply system as shown in Figure 1. Requirements from both networks shall be applied, see 5.3.

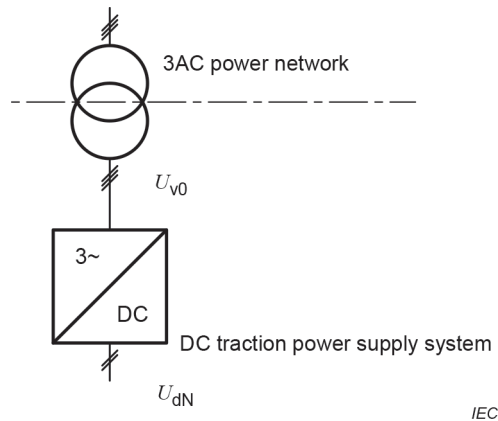

Figure 1 – General arrangement of AC/DC converters

4.2.1.2 Rectifiers

The purpose of rectifiers is to have a power flow from the 3AC power network to the DC electric traction power supply system.

Controlled rectifiers operate on an adjustable characteristic curve in the current versus voltage plane. This characteristic can be adjustable. Examples are given in Annex A. Limits can be included.

Controlled rectifiers can be line-commutated or self-commutated.

A suitable duty class should be chosen from IEC 62590-1:2025, 5.7.2.

4.2.1.3 Inverters

The purpose of inverters is to enable a power flow from the DC electric traction power supply system to the 3AC power network to improve the energy efficiency of the railway system.

Inverters operate on an adjustable characteristic curve in the current versus voltage plane. This characteristic can be adjustable. Examples are given in Annex A. Limits can be included.

Inverters can be line-commutated or self-commutated.

The definition of a load cycle is appropriate in most cases, see IEC 62590-1:2025, 5.7.3.

4.2.1.4 Reversible converters

The purpose of the combination of a rectifier and an inverter is to enable a bidirectional power exchange between a 3AC power network and the DC electric traction power supply system.

Reversible converters operate on an adjustable characteristic curve in the current versus voltage plane. This characteristic can be adjustable. Examples are given in Annex A. Limits can be included.

There is a broad variety of combinations using line-commutated and self-commutated converters, see Table 2.

Figure 2 to Figure 5 show various possible combinations of rectifiers and inverters that can be installed in a reversible substation. They can share the same transformer, the same control, or the same filter.

Commonly used parts of the reversible converter are subject to a combined load requirement.

For the rectifier part a suitable duty class should be chosen. For the inverter part a suitable load cycle or a suitable duty class should be chosen according to the application, see Figure 2 to Figure 5. This can result in an asymmetric load for 3 winding transformers in special cases shown in Figure 3 and Figure 4.

IEC 62590-2-1 applies to the uncontrolled part of the reversible converter, if any, and this document applies to the inverter part.

Table 2 – Rectifiers, inverters and combinations

	Rectifier	Inverter	Reversible converter
General symbol			
Examples of associated transformer and valve device assembly	 	 	
NOTE 1	The symbols represent typical valve devices used in the respective application.		
NOTE 2	"Rec" indicates the use of a rectifier and "Inv" the use of an inverter.		

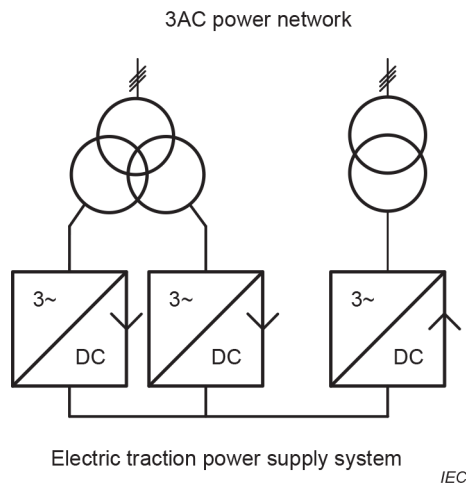
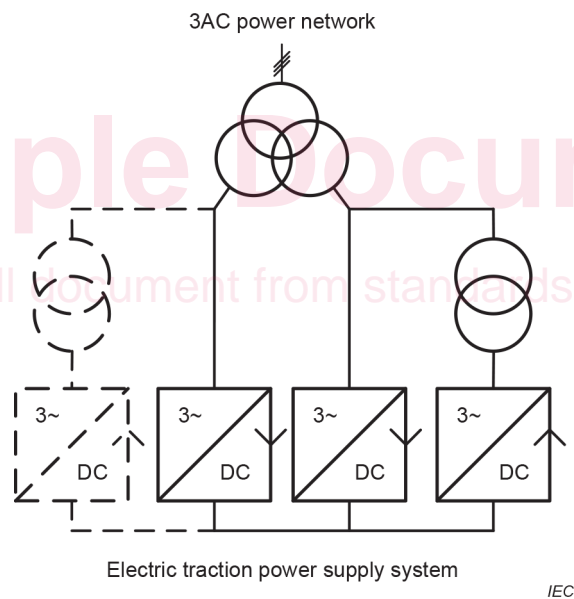

Figure 2 – Connection with separate transformers

A reversible converter configuration can consist of a separated rectifier and inverter. Figure 2 shows such a configuration. Both can be connected to the same 3AC power network or to different 3AC power networks. The function and design are as independent as possible.



NOTE Dashed symbols represent optional components to achieve symmetry.

Figure 3 – Connection with combined transformer

A reversible converter configuration can share the same main transformer. Such a configuration is shown in Figure 3. In this case an additional transformer is used to adapt the inverter 3AC voltage to the rectifier 3AC voltage. If a three-winding transformer with two traction side windings is used, a single inverter or multiple inverters can be connected to one or both windings equally. The main transformer shall be designed for both power flow directions.

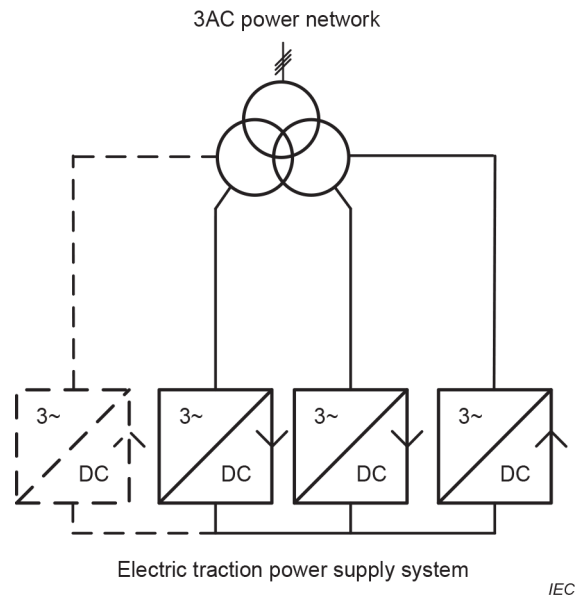

NOTE Dashed symbols represent optional components to achieve symmetry.

Figure 4 – Connection with combined transformer with taps

Figure 4 shows a configuration with a combined transformer with taps. No additional transformer is used for the adaptation of the inverter and rectifier voltage.

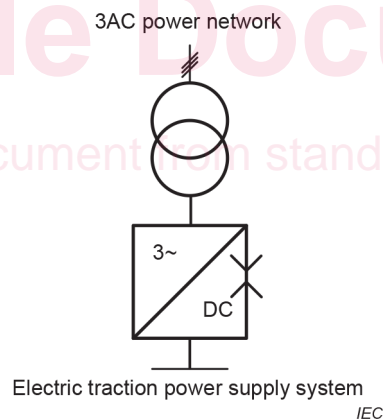

Figure 5 – Converter with reversible valve device assembly

Figure 5 shows the configuration of a reversible converter using a unique all-in-one reversible valve device assembly associated with a unique transformer. In this case, the control for both flow directions is integrated.

More than one traction side transformer winding can be used.

4.2.1.5 Reversible AC/DC converters for energy storages

The purpose of a reversible converter for an energy storage is to connect the DC electric traction power supply system to an energy storage unit. In this case the ESU is a rotating machine.

IEC 62924 covers reversible converters for energy storage. The converter fulfils the function of the ACTB.

The configuration is shown in Figure 6.