

INTERNATIONAL STANDARD

NORME INTERNATIONALE

**Electric motor-operated hand-held tools, transportable tools and lawn and garden machinery - Safety -
Part 3-16: Particular requirements for transportable belt sanders, disc sanders and belt/disc sanders**

**Outils électroportatifs à moteur, outils portables et machines pour jardins et pelouses - Sécurité -
Partie 3-16: Exigences particulières pour les ponceuses à bande, les ponceuses à disque et les ponceuses à bande/disque portables**



THIS PUBLICATION IS COPYRIGHT PROTECTED
Copyright © 2025 IEC, Geneva, Switzerland

All rights reserved. Unless otherwise specified, no part of this publication may be reproduced or utilized in any form or by any means, electronic or mechanical, including photocopying and microfilm, without permission in writing from either IEC or IEC's member National Committee in the country of the requester. If you have any questions about IEC copyright or have an enquiry about obtaining additional rights to this publication, please contact the address below or your local IEC member National Committee for further information.

Droits de reproduction réservés. Sauf indication contraire, aucune partie de cette publication ne peut être reproduite ni utilisée sous quelque forme que ce soit et par aucun procédé, électronique ou mécanique, y compris la photocopie et les microfilms, sans l'accord écrit de l'IEC ou du Comité national de l'IEC du pays du demandeur. Si vous avez des questions sur le copyright de l'IEC ou si vous désirez obtenir des droits supplémentaires sur cette publication, utilisez les coordonnées ci-après ou contactez le Comité national de l'IEC de votre pays de résidence.

IEC Secretariat
3, rue de Varembe
CH-1211 Geneva 20
Switzerland

Tel.: +41 22 919 02 11
info@iec.ch
www.iec.ch

About the IEC

The International Electrotechnical Commission (IEC) is the leading global organization that prepares and publishes International Standards for all electrical, electronic and related technologies.

About IEC publications

The technical content of IEC publications is kept under constant review by the IEC. Please make sure that you have the latest edition, a corrigendum or an amendment might have been published.

IEC publications search -

webstore.iec.ch/advsearchform

The advanced search enables to find IEC publications by a variety of criteria (reference number, text, technical committee, ...). It also gives information on projects, replaced and withdrawn publications.

IEC Just Published - webstore.iec.ch/justpublished

Stay up to date on all new IEC publications. Just Published details all new publications released. Available online and once a month by email.

IEC Customer Service Centre - webstore.iec.ch/csc

If you wish to give us your feedback on this publication or need further assistance, please contact the Customer Service Centre: sales@iec.ch.

IEC Products & Services Portal - products.iec.ch

Discover our powerful search engine and read freely all the publications previews, graphical symbols and the glossary. With a subscription you will always have access to up to date content tailored to your needs.

Electropedia - www.electropedia.org

The world's leading online dictionary on electrotechnology, containing more than 22 500 terminological entries in English and French, with equivalent terms in 25 additional languages. Also known as the International Electrotechnical Vocabulary (IEV) online.

A propos de l'IEC

La Commission Electrotechnique Internationale (IEC) est la première organisation mondiale qui élabore et publie des Normes internationales pour tout ce qui a trait à l'électricité, à l'électronique et aux technologies apparentées.

A propos des publications IEC

Le contenu technique des publications IEC est constamment revu. Veuillez vous assurer que vous possédez l'édition la plus récente, un corrigendum ou amendement peut avoir été publié.

Recherche de publications IEC -

webstore.iec.ch/advsearchform

La recherche avancée permet de trouver des publications IEC en utilisant différents critères (numéro de référence, texte, comité d'études, ...). Elle donne aussi des informations sur les projets et les publications remplacées ou retirées.

IEC Just Published - webstore.iec.ch/justpublished

Restez informé sur les nouvelles publications IEC. Just Published détaille les nouvelles publications parues. Disponible en ligne et une fois par mois par email.

Service Clients - webstore.iec.ch/csc

Si vous désirez nous donner des commentaires sur cette publication ou si vous avez des questions contactez-nous: sales@iec.ch.

IEC Products & Services Portal - products.iec.ch

Découvrez notre puissant moteur de recherche et consultez gratuitement tous les aperçus des publications, symboles graphiques et le glossaire. Avec un abonnement, vous aurez toujours accès à un contenu à jour adapté à vos besoins.

Electropedia - www.electropedia.org

Le premier dictionnaire d'électrotechnologie en ligne au monde, avec plus de 22 500 articles terminologiques en anglais et en français, ainsi que les termes équivalents dans 25 langues additionnelles. Egalement appelé Vocabulaire Electrotechnique International (IEV) en ligne.

Warning! Make sure that you obtained this publication from an authorized distributor.

Attention! Veuillez vous assurer que vous avez obtenu cette publication via un distributeur agréé.

CONTENTS

FOREWORD	2
1 Scope	4
2 Normative references	4
3 Terms and definitions	4
4 General requirements	6
5 General conditions for the tests	6
6 Radiation, toxicity and similar hazards	7
7 Classification	7
8 Marking and instructions	7
9 Protection against access to live parts	8
10 Starting	8
11 Input and current	8
12 Heating	9
13 Resistance to heat and fire	9
14 Moisture resistance	9
15 Resistance to rusting	9
16 Overload protection of transformers and associated circuits	9
17 Endurance	9
18 Abnormal operation	9
19 Mechanical hazards	10
20 Mechanical strength	13
21 Construction	13
22 Internal wiring	14
23 Components	14
24 Supply connection and external flexible cords	14
25 Terminals for external conductors	14
26 Provision for earthing	14
27 Screws and connections	14
28 Creepage distances, clearances and distances through insulation	14
Annexes	15
Annex I (informative) Measurement of noise and vibration emissions	16
Annex K (normative) Battery tools and battery packs	17
Annex L (normative) Battery tools and battery packs provided with mains connection or non-isolated sources	18
Bibliography	19
Figure 101 – Example of a belt disc sander	6
Figure 102 – Rod test for the in-feed nip between the belt and roller	11
Figure 103 – Steel ball test	12
Table 4 – Required performance levels	10

INTERNATIONAL ELECTROTECHNICAL COMMISSION

**Electric motor-operated hand-held tools, transportable tools
and lawn and garden machinery - Safety -
Part 3-16: Particular requirements for transportable belt sanders,
disc sanders and belt/disc sanders**

FOREWORD

- 1) The International Electrotechnical Commission (IEC) is a worldwide organization for standardization comprising all national electrotechnical committees (IEC National Committees). The object of IEC is to promote international co-operation on all questions concerning standardization in the electrical and electronic fields. To this end and in addition to other activities, IEC publishes International Standards, Technical Specifications, Technical Reports, Publicly Available Specifications (PAS) and Guides (hereafter referred to as "IEC Publication(s)"). Their preparation is entrusted to technical committees; any IEC National Committee interested in the subject dealt with may participate in this preparatory work. International, governmental and non-governmental organizations liaising with the IEC also participate in this preparation. IEC collaborates closely with the International Organization for Standardization (ISO) in accordance with conditions determined by agreement between the two organizations.
- 2) The formal decisions or agreements of IEC on technical matters express, as nearly as possible, an international consensus of opinion on the relevant subjects since each technical committee has representation from all interested IEC National Committees.
- 3) IEC Publications have the form of recommendations for international use and are accepted by IEC National Committees in that sense. While all reasonable efforts are made to ensure that the technical content of IEC Publications is accurate, IEC cannot be held responsible for the way in which they are used or for any misinterpretation by any end user.
- 4) In order to promote international uniformity, IEC National Committees undertake to apply IEC Publications transparently to the maximum extent possible in their national and regional publications. Any divergence between any IEC Publication and the corresponding national or regional publication shall be clearly indicated in the latter.
- 5) IEC itself does not provide any attestation of conformity. Independent certification bodies provide conformity assessment services and, in some areas, access to IEC marks of conformity. IEC is not responsible for any services carried out by independent certification bodies.
- 6) All users should ensure that they have the latest edition of this publication.
- 7) No liability shall attach to IEC or its directors, employees, servants or agents including individual experts and members of its technical committees and IEC National Committees for any personal injury, property damage or other damage of any nature whatsoever, whether direct or indirect, or for costs (including legal fees) and expenses arising out of the publication, use of, or reliance upon, this IEC Publication or any other IEC Publications.
- 8) Attention is drawn to the Normative references cited in this publication. Use of the referenced publications is indispensable for the correct application of this publication.
- 9) IEC draws attention to the possibility that the implementation of this document may involve the use of (a) patent(s). IEC takes no position concerning the evidence, validity or applicability of any claimed patent rights in respect thereof. As of the date of publication of this document, IEC had not received notice of (a) patent(s), which may be required to implement this document. However, implementers are cautioned that this may not represent the latest information, which may be obtained from the patent database available at <https://patents.iec.ch>. IEC shall not be held responsible for identifying any or all such patent rights.

IEC 62841-3-16 has been prepared by IEC technical committee 116: Safety of motor-operated electric tools. It is an International Standard.

The text of this International Standard is based on the following documents:

Draft	Report on voting
116/915/FDIS	116/927/RVD

Full information on the voting for its approval can be found in the report on voting indicated in the above table.

The language used for the development of this International Standard is English.

This document was drafted in accordance with ISO/IEC Directives, Part 2, and developed in accordance with ISO/IEC Directives, Part 1 and ISO/IEC Directives, IEC Supplement, available at www.iec.ch/members_experts/refdocs. The main document types developed by IEC are described in greater detail at www.iec.ch/publications.

This Part 3-16 is to be used in conjunction with the first edition of IEC 62841-1:2014 and IEC 62841-1:2014/AMD1:2025.

This Part 3-16 supplements or modifies the corresponding clauses in IEC 62841-1:2014, so as to convert it into the IEC Standard: Particular requirements for transportable belt sanders, disc sanders and belt/disc sanders.

Where a particular subclause of IEC 62841-1:2014 is not mentioned in this Part 3-16, that subclause applies as far as relevant. Where this document states "addition", "modification" or "replacement", the relevant text in IEC 62841-1:2014 is to be adapted accordingly.

The following print types are used:

- *test specifications: in italic type;*
- Subclauses, notes, tables and figures which are additional to those in IEC 62841-1:2014, except as described for Annex K and Annex L below, are numbered starting from 101.
- Subclauses, notes, tables and figures in Annex K and Annex L which are additional to those in the main body of this document are numbered starting from 301.

NOTE The attention of National Committees is drawn to the fact that equipment manufacturers and testing organizations can need a transitional period following publication of a new, amended or revised IEC publication in which to make products in accordance with the new requirements and to equip themselves for conducting new or revised tests.

It is the recommendation of the committee that the content of this publication be adopted for implementation nationally not earlier than 36 months from the date of publication.

A list of all parts of the IEC 62841 series, under the general title: *Electric motor-operated hand-held tools, transportable tools and lawn and garden machinery - Safety*, can be found on the IEC website.

The committee has decided that the contents of this document will remain unchanged until the stability date indicated on the IEC website under webstore.iec.ch in the data related to the specific document. At this date, the document will be

- reconfirmed,
- withdrawn, or
- revised.

1 Scope

IEC 62841-1:2014, Clause 1 is applicable, except as follows.

Addition:

This document applies to transportable **belt sanders**, **disc sanders** and **belt/disc sanders** which are equipped with

- a **sanding belt**; or
- a **sanding disc**; or
- a **sanding belt** and a **sanding disc**

for sanding solid materials.

This document does not apply to hand-held disc-type sanders.

NOTE 101 Hand-held disc-type sanders are covered by IEC 62841-2-3.

This document does not apply to hand-held **belt sanders**.

NOTE 102 Hand-held **belt sanders** are covered by IEC 62841-2-4.

2 Normative references

IEC 62841-1:2014, Clause 2 is applicable, except as follows.

Addition:

IEC 62841-1:2014, *Electric motor-operated hand-held tools, transportable tools and lawn and garden machinery - Safety - Part 1: General requirements*
IEC 62841-1:2014/AMD1:2025

3 Terms and definitions

IEC 62841-1:2014, Clause 3 and IEC 62841-1:2014/AMD1:2025, Clause 3 are applicable, except as follows.

Addition:

3.101

back stop

surface or device intended to support or to guide the workpiece when sanding with a **sanding belt**

3.102

belt sander

tool designed for sanding, equipped with a **sanding belt** that is rotated over a flat surface

3.103

belt/disc sander

tool designed for sanding, equipped with

- a **sanding belt** that is rotated over a flat surface; and
- a **sanding disc** that is mounted on a flat surface and provided with a **work table**

Note 1 to entry: See Figure 101.

3.104

disc sander

tool designed for sanding, equipped with a **sanding disc** that is mounted on a flat surface and provided with a **work table**

3.105

sanding belt

endless belt surfaced with an abrasive used for sanding

3.106

sanding disc

disc surfaced with an abrasive used for sanding

3.107

work table

surface or device intended to support or to guide the workpiece when sanding with a **sanding disc**

Sample Document

get full document from standards.iteh.ai

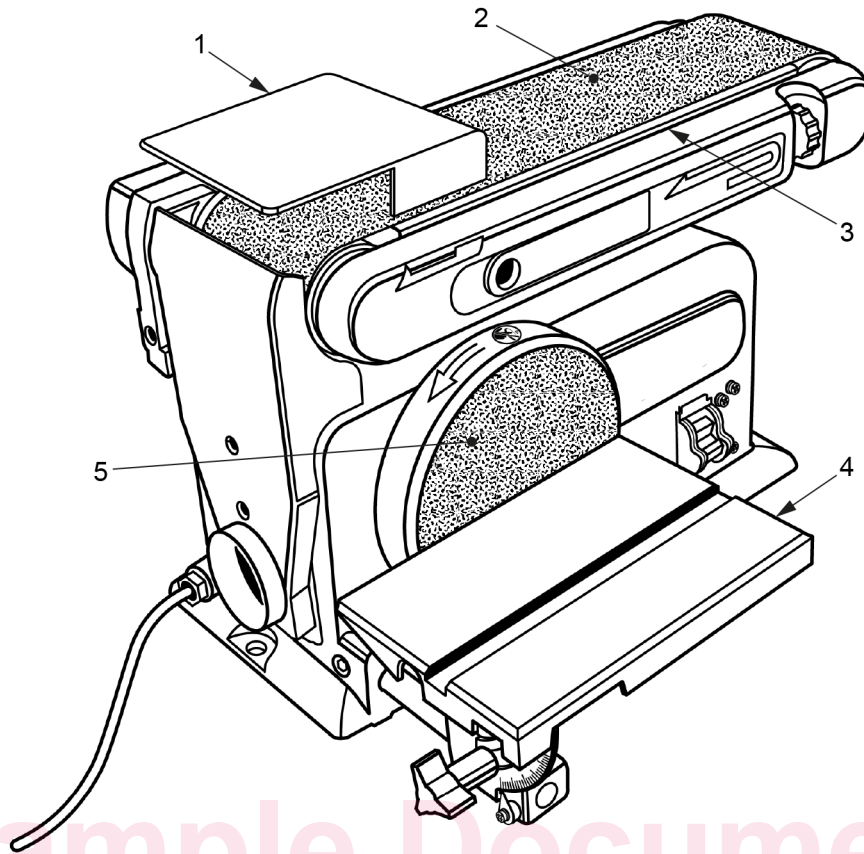

Sample Document

IEC

Key

- 1 back stop
- 2 sanding belt
- 3 sanding belt support plate
- 4 work table
- 5 sanding disc

Figure 101 – Example of a belt disc sander

4 General requirements

IEC 62841-1:2014, Clause 4 is applicable.

5 General conditions for the tests

IEC 62841-1:2014, Clause 5 is applicable, except as follows.

5.17 Addition:

*The mass of the tool includes the **back stop** and **work table**, as applicable. Any additional parts such as leg sets or carrying means that are required in accordance with 8.14.2 are included in the mass.*

6 Radiation, toxicity and similar hazards

IEC 62841-1:2014, Clause 6 is applicable.

7 Classification

IEC 62841-1:2014, Clause 7 is applicable.

8 Marking and instructions

IEC 62841-1:2014, Clause 8 and IEC 62841-1:2014/AMD1:2025, Clause 8 are applicable, except as follows:

8.2 Addition:

Tools shall be marked with:

- "⚠️ WARNING – Always wear eye protection" or the symbol M004 of ISO 7010 (2011-05).

NOTE 101 In Canada and the United States of America, the following additional markings are applicable.

For **belt sanders**:

- "⚠️ WARNING – Support the workpiece with the back stop";
- "⚠️ WARNING – Maintain a 2 mm maximum clearance between the back stop and the sanding belt".

The above marking is omitted for **belt sanders** provided with a fixed (non-adjustable) **back stop**.

For **disc sanders**:

- "⚠️ WARNING – Support the workpiece with the work table";
- "⚠️ WARNING – Maintain a 2 mm maximum clearance between the work table and the sanding disc"

The above marking is omitted for **disc sanders** provided with a fixed (non-adjustable) **work table**.

For **belt/disc sanders**:

- "⚠️ WARNING – Support the workpiece with the back stop or the work table";
- "⚠️ WARNING – Maintain a 2 mm maximum clearance between the back stop and the sanding belt, and the work table and the sanding disc".

The above marking is omitted or modified, as appropriate, for **belt/disc sanders** provided with a fixed (non-adjustable) **back stop** and/or **work table**.

8.3 Addition:

Tools shall be marked with the direction of rotation of the **sanding belt** and **sanding disc**, as applicable, indicated on the tool by an arrow, raised or sunk, or by any other means no less visible and indelible.

8.14.1 Addition:

The additional safety instructions as specified in 8.14.1.101 shall be given. This part may be printed separately from the "General Power Tool Safety Warnings".

8.14.1.101 Safety instructions for belt sanders, disc sanders and belt/disc sanders

- a) **To prevent kickback when sanding, use the back stop or work table to support the workpiece, maintain a firm grip with both hands on the workpiece and position your body and arms to resist kickback forces. Do not stand in line with a belt of a belt sander. Do not lean over a disc of a disc sander. Kickback could cause the workpiece to be thrown toward the operator, which may result in personal injury.**

NOTE 1 For **belt sanders** with no provision for mounting a **sanding disc**, the text "or work table" and "Do not lean over a disc of a disc sander." in item a) above is omitted.

NOTE 2 For **disc sanders** with no provision for mounting a **sanding belt**, the text "back stop or" and "Do not stand in line with a belt of a belt sander." in item a) above is omitted.

- b) **Maintain a maximum clearance of 2 mm between the sanding belt and the back stop. Larger clearances increase the risk of fingers or the hand being drawn in between the sanding belt and the back stop, which may result in personal injury.**

NOTE 3 The warning in item b) above is omitted for **disc sanders** with no provision for mounting a **sanding belt**.

NOTE 4 The warning in item b) above is omitted for **belt sanders** and **belt/disc sanders** provided with a fixed (non-adjustable) **back stop**.

- c) **Maintain a maximum clearance of 2 mm between the sanding disc and work table. Larger clearances increase the risk of fingers or the hand being drawn in between the sanding disc and the work table, which may result in personal injury.**

NOTE 5 The warning in item c) above is omitted for **belt sanders** with no provision for mounting a **sanding disc**.

NOTE 6 The warning in item c) above is omitted for **disc sanders** and **belt/disc sanders** provided with a fixed (non-adjustable) **work table**.

8.14.2 a) Addition:

- 101) Instructions on how to adjust the **back stop** and **work table**, as applicable;
- 102) Information on recommended **sanding belts** and/or **sanding discs** for use with the tool;
- 103) Instructions on how to mount and adjust the **sanding belt** and/or **sanding disc**;
- 104) Instruction how to connect dust extraction systems.

8.14.2 b) Addition:

- 101) Instructions on proper sanding operations;
- 102) Information on the direction of rotation markings for the **sanding belt** and **sanding disc**, as applicable, in accordance with 8.3;
- 103) For **belt sanders** and **belt/disc sanders**, information of the working area of the **sanding belt**.

9 Protection against access to live parts

IEC 62841-1:2014, Clause 9 is applicable.

10 Starting

IEC 62841-1:2014, Clause 10 is applicable.

11 Input and current

IEC 62841-1:2014, Clause 11 is applicable.

12 Heating

IEC 62841-1:2014, Clause 12 is applicable.

13 Resistance to heat and fire

IEC 62841-1:2014, Clause 13 is applicable.

14 Moisture resistance

IEC 62841-1:2014, Clause 14 is applicable.

15 Resistance to rusting

IEC 62841-1:2014, Clause 15 is applicable.

16 Overload protection of transformers and associated circuits

IEC 62841-1:2014, Clause 16 is applicable.

17 Endurance

IEC 62841-1:2014, Clause 17 is applicable.

18 Abnormal operation

IEC 62841-1:2014, Clause 18 is applicable, except as follows.

18.5 Addition:

For tools operated by three phase motors, the tests of 18.5.1 and 18.5.2 may be replaced by the test of 18.5.3.

18.5.3 Addition:

If the test of 18.5.3 is applied, the tool is tested for a period of 5 min.

18.8.1 General

Replacement of Table 4:

Table 4 – Required performance levels

Type and purpose of SCF	Minimum Performance Level (PL)
Power switch – prevent unwanted switch-on	b
Power switch – provide desired switch-off	a
<i>Any electronic control to pass the test of 18.3</i>	a
Provide desired direction of rotation	a
Prevent exceeding thermal limits as in 18.4 and 18.5.3	a
Prevent self-resetting as required in 23.3	a

19 Mechanical hazards

IEC 62841-1:2014, Clause 19 is applicable, except as follows.

19.1 Replacement of the first paragraph:

All power-driven hazardous parts (e.g. gears), other than the **accessories** which are separately covered by 19.101 to 19.103, shall be so positioned or enclosed to provide adequate protection.

19.6 This subclause is not applicable.

19.7 Addition:

If a working stand is provided with the tool, or is specifically identified in accordance with 8.14.2, the requirements of 19.7 are also applicable to the combination of the tool and working stand.

19.101 Belt sanders and belt/disc sanders shall be designed to minimize the risk due to nip hazard from the **sanding belt**.

Compliance is checked by the following tests.

*A rigid test rod with 8 mm diameter, applied parallel to the axis of each **sanding belt** roller, shall not be able to enter the in-feed nip between the roller and the **sanding belt**. As the rod is attempted to be inserted into this area, the **sanding belt** shall not be displaced in any way that would allow the entry of the rod. See Figure 102.*

*The **sanding belt** is then removed. A steel ball with 7 mm diameter is placed all along the infeed gap between the intended **sanding belt** contact surface of the roller and the **sanding belt** housing enclosure with the tool adjusted to the most unfavourable position in accordance with 8.14.2, see Figure 103. The steel ball shall not move under its own weight into the gap between the roller and the **sanding belt** housing beyond the line of complete passage as shown in Figure 103.*