



IEC 80601-2-52

Edition 1.0 2026-05

INTERNATIONAL STANDARD

**Medical electrical equipment -
Part 2-52: Particular requirements for the basic safety and essential performance
of medical beds for adults**

Sample Document

get full document from standards.iteh.ai



THIS PUBLICATION IS COPYRIGHT PROTECTED
Copyright © 2026 IEC, Geneva, Switzerland

All rights reserved. Unless otherwise specified, no part of this publication may be reproduced or utilized in any form or by any means, electronic or mechanical, including photocopying and microfilm, without permission in writing from either IEC or IEC's member National Committee in the country of the requester. If you have any questions about IEC copyright or have an enquiry about obtaining additional rights to this publication, please contact the address below or your local IEC member National Committee for further information.

IEC Secretariat
3, rue de Varembe
CH-1211 Geneva 20
Switzerland

Tel.: +41 22 919 02 11
info@iec.ch
www.iec.ch

About the IEC

The International Electrotechnical Commission (IEC) is the leading global organization that prepares and publishes International Standards for all electrical, electronic and related technologies.

About IEC publications

The technical content of IEC publications is kept under constant review by the IEC. Please make sure that you have the latest edition, a corrigendum or an amendment might have been published.

IEC publications search -
webstore.iec.ch/advsearchform

The advanced search enables to find IEC publications by a variety of criteria (reference number, text, technical committee, ...). It also gives information on projects, replaced and withdrawn publications.

IEC Just Published - webstore.iec.ch/justpublished

Stay up to date on all new IEC publications. Just Published details all new publications released. Available online and once a month by email.

IEC Customer Service Centre - webstore.iec.ch/csc

If you wish to give us your feedback on this publication or need further assistance, please contact the Customer Service Centre: sales@iec.ch.

IEC Products & Services Portal - products.iec.ch

Discover our powerful search engine and read freely all the publications previews, graphical symbols and the glossary. With a subscription you will always have access to up to date content tailored to your needs.

Electropedia - www.electropedia.org

The world's leading online dictionary on electrotechnology, containing more than 22 500 terminological entries in English and French, with equivalent terms in 25 additional languages. Also known as the International Electrotechnical Vocabulary (IEV) online.

Warning! Make sure that you obtained this publication from an authorized distributor.

CONTENTS

FOREWORD	4
INTRODUCTION	7
201.1 Scope, object and related standards	8
201.2 Normative references	10
201.3 Terms and definitions	10
201.4 General requirements	15
201.5 General requirements for testing of ME EQUIPMENT	16
201.6 Classification of ME EQUIPMENT and ME SYSTEMS	19
201.7 ME EQUIPMENT identification, marking and documents	19
201.8 Protection against electrical HAZARDS from ME EQUIPMENT	25
201.9 Protection against MECHANICAL HAZARDS of ME EQUIPMENT and ME SYSTEMS	26
201.10 Protection against unwanted and excessive radiation HAZARDS	53
201.11 Protection against excessive temperatures and other HAZARDS	53
201.12 Accuracy of controls and instruments and protection against hazardous outputs	57
201.13 HAZARDOUS SITUATIONS and fault conditions for ME EQUIPMENT	57
201.14 PROGRAMMABLE ELECTRICAL MEDICAL SYSTEMS (PEMS)	58
201.15 Construction of ME EQUIPMENT	58
201.16 ME SYSTEMS	63
201.17 Electromagnetic compatibility of ME EQUIPMENT and ME SYSTEMS	63
Annexes	64
Annex AA (informative) Particular guidance and rationale	65
Annex BB (normative) Additional design requirements and recommendations for MEDICAL BEDS	84
Annex CC (informative) Particular guidance for assessing RISK of entrapment in V-shaped openings	89
Annex DD (informative) Guidance and recommendations for periodic inspection	95
Bibliography	97
Index of defined terms	98
Figure 201.101 – MEDICAL BED, general arrangement (example, schematic presentation only)	13
Figure 201.102 – HEAD DOWN TILT, Example	15
Figure 201.103 – FOOT DOWN TILT, Example	15
Figure 201.104 – Entrapment test tools	17
Figure 201.105 – Loading pad	18
Figure 201.106 – Impactor	18
Figure 201.107 – Ball chain loop and spherical mass	19
Figure 201.108 – Graphic symbol for maximum PATIENT weight and SAFE WORKING LOAD	20
Figure 201.109 – Graphic symbol for mass; weight	20
Figure 201.110 – Graphic symbol for machine washable MEDICAL BED	20
Figure 201.111 – Graphic symbol for jet stream washable MEDICAL BED	21
Figure 201.112 – Graphic symbol for manual cleaning only	21

Figure 201.113 – Physical description of PATIENT	22
Figure 201.114 – MEDICAL BED function controls or actuators or both: guidelines for creating graphic symbols	23
Figure 201.115 – Example of MEDICAL BED with segmented or split SIDE RAIL	27
Figure 201.116 – Example of MEDICAL BED with single piece SIDE RAIL	28
Figure 201.117 – Allowable spacing for fingers in areas of normal reach around the perimeter of the MATTRESS SUPPORT PLATFORM	33
Figure 201.118 – Example using barriers for clearance measurement around the perimeter of the MATTRESS SUPPORT PLATFORM to mitigate PATIENT finger entrapment	34
Figure 201.119 – Clearance areas	35
Figure 201.120 – Retention of loop and mass	37
Figure 201.121 – Lateral stability test along the side of the MEDICAL BED	39
Figure 201.122 – Longitudinal stability test with removable FOOT BOARD	40
Figure 201.123 – Longitudinal stability test with fixed HEAD BOARD and FOOT BOARD	40
Figure 201.124 – Distribution of SAFE WORKING LOAD / maximum PATIENT weight for tests	44
Figure 201.125 – Positions of dynamic loading (see Figure 201.103 for loading pad and Figure 201.104 for impactor)	47
Figure 201.126 – Application of forces for test of SIDE RAIL	49
Figure 201.127 – Height of SIDE RAIL	52
Figure 201.128 – Direction of movement for rough handling test	59
Figure 201.129 – Configurations of the MATTRESS SUPPORT PLATFORM	61
Figure AA.1 – Example of marking to select recommended mattresses specified by the MANUFACTURER	68
Figure AA.2 – Example of marking for detachable SIDE RAILS specified by the MANUFACTURER	68
Figure AA.3 – Examples of marking on the MEDICAL BED of storage location for wired and wireless PENDANT CONTROLS	69
Figure AA.4 – Resultant forces without mattress	72
Figure AA.5 – Resultant forces with mattress	72
Figure AA.6 – Example of 60 mm gap measurement of B	73
Figure AA.7 – Angle measurement example of B	73
Figure AA.8 – Placement of measurement TOOL for measurement of D	74
Figure AA.9 – Example of area D measurement that passes	74
Figure AA.10 – Example of area D measurement that fails (on limit)	75
Figure AA.11 – Example of area D measurement that fails	75
Figure AA.12 – Example of potential PATIENT entrapment in area A within the SIDE RAIL	75
Figure AA.13 – Example of potential PATIENT entrapment in area A below the SIDE RAIL	76
Figure AA.14 – Example of potential PATIENT entrapment in area B	76
Figure AA.15 – Example of potential PATIENT entrapment in area C between split SIDE RAIL	76
Figure AA.16 – Example of potential PATIENT entrapment in area C between SIDE RAIL and HEAD BOARD	76
Figure AA.17 – Example of potential PATIENT entrapment in area D	77
Figure AA.18 – Example of potential PATIENT entrapment in area A below a single piece SIDE RAIL	77

Figure AA.19 – Concept of potential PATIENT foot-first entrapment tool for area A below a SIDE RAIL	78
Figure BB.1 – Schematic presentation of under MEDICAL BED clearance.....	86
Figure BB.2 – Recommendations and requirements regarding angles for different sections of the MATTRESS SUPPORT PLATFORM	88
Figure CC.1 – Wedge tool.....	90
Figure CC.2 – V-shaped opening in relation to B.....	91
Figure CC.3 – Acceptance criteria in relation to area B	92
Figure CC.4 – Positioning of wedge TOOL.....	93
Figure CC.5 – Acceptance criteria in relation to area C between HEAD BOARD and FOOT BOARD	93
Figure CC.6 – Acceptance criteria in relation to area C between split SIDE RAILS	94
Table 201.101 – Protection against PATIENT entrapment	29
Table 201.102 – Minimum SAFE WORKING LOADS	43
Table 201.103 – Protection against inadvertent PATIENT falls	53
Table 24 – Allowable maximum temperatures for skin contact with MEDICAL BED APPLIED PARTS.....	53
Table 201.104 – Machine washable compliance PROCEDURE	55

Sample Document

get full document from standards.iteh.ai

INTERNATIONAL ELECTROTECHNICAL COMMISSION

**Medical electrical equipment -
Part 2-52: Particular requirements for the basic safety
and essential performance of medical beds for adults**

FOREWORD

- 1) The International Electrotechnical Commission (IEC) is a worldwide organization for standardization comprising all national electrotechnical committees (IEC National Committees). The object of IEC is to promote international co-operation on all questions concerning standardization in the electrical and electronic fields. To this end and in addition to other activities, IEC publishes International Standards, Technical Specifications, Technical Reports, Publicly Available Specifications (PAS) and Guides (hereafter referred to as "IEC Publication(s)"). Their preparation is entrusted to technical committees; any IEC National Committee interested in the subject dealt with may participate in this preparatory work. International, governmental and non-governmental organizations liaising with the IEC also participate in this preparation. IEC collaborates closely with the International Organization for Standardization (ISO) in accordance with conditions determined by agreement between the two organizations.
- 2) The formal decisions or agreements of IEC on technical matters express, as nearly as possible, an international consensus of opinion on the relevant subjects since each technical committee has representation from all interested IEC National Committees.
- 3) IEC Publications have the form of recommendations for international use and are accepted by IEC National Committees in that sense. While all reasonable efforts are made to ensure that the technical content of IEC Publications is accurate, IEC cannot be held responsible for the way in which they are used or for any misinterpretation by any end user.
- 4) In order to promote international uniformity, IEC National Committees undertake to apply IEC Publications transparently to the maximum extent possible in their national and regional publications. Any divergence between any IEC Publication and the corresponding national or regional publication shall be clearly indicated in the latter.
- 5) IEC itself does not provide any attestation of conformity. Independent certification bodies provide conformity assessment services and, in some areas, access to IEC marks of conformity. IEC is not responsible for any services carried out by independent certification bodies.
- 6) All users should ensure that they have the latest edition of this publication.
- 7) No liability shall attach to IEC or its directors, employees, servants or agents including individual experts and members of its technical committees and IEC National Committees for any personal injury, property damage or other damage of any nature whatsoever, whether direct or indirect, or for costs (including legal fees) and expenses arising out of the publication, use of, or reliance upon, this IEC Publication or any other IEC Publications.
- 8) Attention is drawn to the Normative references cited in this publication. Use of the referenced publications is indispensable for the correct application of this publication.
- 9) IEC and ISO draw attention to the possibility that the implementation of this document may involve the use of (a) patent(s). IEC and ISO take no position concerning the evidence, validity or applicability of any claimed patent rights in respect thereof. As of the date of publication of this document, IEC and ISO had not received notice of (a) patent(s), which may be required to implement this document. However, implementers are cautioned that this may not represent the latest information, which may be obtained from the patent database available at <https://patents.iec.ch>. IEC and ISO shall not be held responsible for identifying any or all such patent rights.

IEC 80601-2-52 has been prepared by a Joint Working Group of IEC subcommittee 62D: Particular medical equipment, software, and systems, of IEC technical committee 62: Medical equipment, software, and systems, and ISO technical committee 173: Assistive products. It is an International Standard.

This first edition cancels and replaces the first edition of IEC 60601-2-52 published in 2009 and its Amendment 1:2015. This edition constitutes a technical revision.

This edition includes the following significant technical changes with respect to the previous edition:

- a) scope updated to state standard applies to both electrical and non-electrical MEDICAL BEDS;
- b) updates to scope to explain the potential overlap with the IEC 80601-2-89;
- c) introduction of APPLICATION ENVIRONMENT 6 (psychiatric care or mental health care environment) and multiple requirements for APPLICATION ENVIRONMENT;

- d) alignment of requirements with IEC 60601-1:2005/AMD2:2020;
- e) new test to address snagging (201.9.3.101);
- f) moved required tests applicable to most application environments from Annex BB to 201.9.8.3.3, so the durability testing is in one subclause;
- g) new rating of jet stream washing and updated requirements in 201.11.6.5;
- h) updated the machine washing test (201.11.6.6.101) to define cycles by application environment and clarified evaluation after cycles;
- i) updated test tools to ensure tolerances and drawings.

It is published as double logo standard.

The text of this International Standard is based on the following documents of IEC:

Draft	Report on voting
62D/2271/FDIS	62D/2291/RVD

Full information on the voting for its approval can be found in the report on voting indicated in the above table.

The language used for the development of this International Standard is English.

This document was drafted in accordance with ISO/IEC Directives, Part 2, and developed in accordance with ISO/IEC Directives, Part 1 and ISO/IEC Directives, IEC Supplement, available at www.iec.ch/members_experts/refdocs. The main document types developed by IEC are described in greater detail at www.iec.ch/publications.

In this document, the following print types are used:

- requirements and definitions: roman type.
- *test specifications: italic type.*
- informative material appearing outside of tables, such as notes, examples and references: in smaller type. Normative text of tables is also in a smaller type.
- TERMS DEFINED IN CLAUSE 3 OF IEC 60601-1:2005, IEC 60601-1:2005/AMD1:2012 and IEC 60601-1:2005/AMD2:2020, in this document or as noted: SMALL CAPITALS.

In referring to the structure of this document, the term

- "clause" means one of the seventeen numbered divisions within the table of contents, inclusive of all subdivisions (e.g. Clause 7 includes subclauses 7.1, 7.2, etc.);
- "subclause" means a numbered subdivision of a clause (e.g. 7.1, 7.2 and 7.2.1 are all subclauses of Clause 7).

References to clauses within this document are preceded by the term "Clause" followed by the clause number. References to subclauses within this particular standard are by number only.

In this document, the conjunctive "or" is used as an "inclusive or" so a statement is true if any combination of the conditions is true.

The verbal forms used in this document conform to usage described in Clause 7 of the ISO/IEC Directives, Part 2. For the purposes of this document, the auxiliary verb:

- "shall" means that compliance with a requirement or a test is mandatory for compliance with this document;
- "should" means that compliance with a requirement or a test is recommended but is not mandatory for compliance with this document;

- "may" is used to describe a permissible way to achieve compliance with a requirement or test.

An asterisk (*) as the first character of a title or at the beginning of a paragraph or table title indicates that there is guidance or rationale related to that item in Annex AA.

A list of all parts of the IEC 80601 series, published under the general title *Medical electrical equipment*, can be found on the IEC website.

The committee has decided that the contents of this document will remain unchanged until the stability date indicated on the IEC website under webstore.iec.ch in the data related to the specific document. At this date, the document will be

- reconfirmed,
- withdrawn, or
- revised.

Sample Document

get full document from standards.iteh.ai

INTRODUCTION

In 1996, the IEC published the first edition of the particular standard for electrically operated hospital beds, IEC 60601-2-38. The publication was in response to demand in the field for a universal standard addressing HAZARDS specific to the safety of the hospital bed. Used in conjunction with a MANUFACTURER'S RISK ASSESSMENT, the standard was felt to be the current thinking on establishing a BASIC SAFETY benchmark for industry.

An amendment of IEC 60601-2-38 issued in 1999 recognized the need to mitigate against a RISK of PATIENT entrapment in the SIDE RAILS, again combined with the use of the MANUFACTURER'S RISK ASSESSMENT. Although this improved the particular standard, it still was centered upon electrically operated hospital beds, and failed to take into account manually operated hospital beds and products in other medical environments.

In 2000, the EN 1970 standard (*Adjustable beds for disabled persons – Requirements and test methods*) was published, which addressed beds used by PERSONS WITH DISABILITY to alleviate or compensate for a disability or handicap. This standard offered a broadened scope in conjunction with IEC 60601-2-38, but after the edition of Amendment 1 to IEC 60601-2-38, the opportunity presented itself to combine the two standards to a common, international standard.

As work began on the integration, the IEC adjusted its stance on BASIC SAFETY and ESSENTIAL PERFORMANCE, integrating them into the third edition of IEC 60601-1 published in 2005. It therefore became necessary to align the new standard with the third edition. The particular standard was given a new number, IEC 60601-2-52, and work began on alignment to third edition.

This particular standard, therefore, is the realization of much work in alignment, and scope adjustment between IEC 60601-2-38, EN 1970, and IEC 60601-1:2005. It represents the current thinking in BASIC SAFETY and ESSENTIAL PERFORMANCE of the MEDICAL BED as used to alleviate illness of PATIENTS and disability of PERSONS WITH DISABILITY. This is the effort of a joint working group of the IEC and the ISO.

IEC 80601-2-52 is a continuation of the IEC 60601-2-52 standard. It will align with the CHILDREN version of the standard, IEC 80601-2-89. The standard number was changed from IEC 60601-2-52 to IEC 80601-2-52 to indicate joint work between the ISO and the IEC.

201.1 Scope, object and related standards

IEC 60601-1:2005, IEC 60601-1:2005/AMD1:2012 and IEC 60601-1:2005/AMD2:2020, Clause 1 applies, except as follows:

201.1.1 * Scope

Replacement:

This International Standard applies to the BASIC SAFETY and ESSENTIAL PERFORMANCE of MEDICAL BEDS as defined in 201.3.214, intended for ADULTS as defined in 201.3.222. Included in the scope are both electrical and non-electrical (manual) MEDICAL BEDS with or without adjustable functions.

This document is applicable to either a BED-LIFT or a detachable MATTRESS SUPPORT PLATFORM or both. The combination of BED-LIFT or a detachable MATTRESS SUPPORT PLATFORM with a compatible non-MEDICAL BED as specified by the MANUFACTURER is also considered a MEDICAL BED.

This document does not apply to:

- MEDICAL BEDS for CHILDREN and ADULTS with atypical anatomies (ADULTS ranging outside the definition for ADULTS in 201.3.222) covered by IEC 80601-2-89[1]¹;
- SPECIALITY MATTRESS covered by ISO 20342 series[2];
- devices for which the INTENDED USE is mainly for examination or transportation under medical supervision (e.g. stretcher, examination table);
- all requirements for MEDICAL BEDS with special functionality.

If a clause or subclause is specifically intended to be applicable to a MEDICAL BED only, or to ME SYSTEMS only, the title and content of that clause or subclause will say so. If that is not the case, the clause or subclause applies both to MEDICAL BED and to ME SYSTEMS, as relevant.

HAZARDS inherent in the intended physiological function of MEDICAL BED or ME SYSTEMS within the scope of this document are not covered by specific requirements in this document except in 7.2.13 and 8.4.1 of IEC 60601-1:2005, IEC 60601-1:2005/AMD1:2012 and IEC 60601-1:2005/AMD2:2020.

NOTE 1 See also 4.2 of IEC 60601-1:2005, IEC 60601-1:2005/AMD1:2012 and IEC 60601-1:2005/AMD2:2020.

NOTE 2 Whenever the term MEDICAL ELECTRICAL EQUIPMENT (MEE, ME EQUIPMENT) is used within the series of IEC 60601 standards, it refers to MEDICAL BEDS (both electrical and non-electrical).

201.1.2 Object

Replacement:

The object of this document is to establish particular BASIC SAFETY and ESSENTIAL PERFORMANCE requirements for MEDICAL BEDS as defined in 201.3.214, intended for ADULTS as defined in 201.3.222.

¹ Numbers in square brackets refer to the Bibliography.

201.1.3 Collateral standards

Addition:

This document refers to those applicable collateral standards that are listed in Clause 2 of IEC 60601-1:2005, IEC 60601-1:2005/AMD1:2012 and IEC 60601-1:2005/AMD2:2020 and Clause 2 of this document.

IEC 60601-1-3 and IEC 60601-1-10 do not apply. All other published collateral standards in the IEC 60601-1 series apply as published.

NOTE Some IEC 60601-1-8 requirements can be excluded if they do not affect PATIENT safety, could lead to user confusion, or are inappropriate to MEDICAL BED usage.

201.1.4 Particular standards

Addition:

In the IEC 60601 series, particular standards may modify, replace or delete requirements contained in IEC 60601-1:2005, IEC 60601-1:2005/AMD1:2012 and IEC 60601-1:2005/AMD2:2020, including the collateral standards as appropriate for the particular ME EQUIPMENT under consideration, and may add other BASIC SAFETY and ESSENTIAL PERFORMANCE requirements.

A requirement of a particular standard takes priority over IEC 60601-1:2005, IEC 60601-1:2005/AMD1:2012 and IEC 60601-1:2005/AMD2:2020

The numbering of clauses and subclauses of this particular standard corresponds to that of IEC 60601-1:2005, IEC 60601-1:2005/AMD1:2012 and IEC 60601-1:2005/AMD2:2020 with the prefix "201" (e.g. 201.1 in this document addresses the content of Clause 1 of IEC 60601-1:2005, IEC 60601-1:2005/AMD1:2012 and IEC 60601-1:2005/AMD2:2020) or applicable collateral standard with the prefix "20x" where x is the final digit(s) of the collateral standard document number (e.g. 202.4 in this document addresses the content of Clause 4 of the IEC 60601-1-2 collateral standard, 203.4 in this document addresses the content of Clause 4 of the IEC 60601-1-3 collateral standard, etc.). The changes to the text of IEC 60601-1:2005, IEC 60601-1:2005/AMD1:2012 and IEC 60601-1:2005/AMD2:2020 are specified by the use of the following words:

"*Replacement*" means that the clause or subclause of IEC 60601-1:2005, IEC 60601-1:2005/AMD1:2012 and IEC 60601-1:2005/AMD2:2020 or applicable collateral standard is replaced completely by the text of this document.

"*Addition*" means that the text of this document is additional to the requirements of IEC 60601-1:2005, IEC 60601-1:2005/AMD1:2012 and IEC 60601-1:2005/AMD2:2020 or applicable collateral standard.

"*Amendment*" means that the clause or subclause of IEC 60601-1:2005, IEC 60601-1:2005/AMD1:2012 and IEC 60601-1:2005/AMD2:2020 or applicable collateral standard is amended as indicated by the text of this document.

Subclauses, figures or tables which are additional to those of IEC 60601-1:2005, IEC 60601-1:2005/AMD1:2012 and IEC 60601-1:2005/AMD2:2020 are numbered starting from 201.101. However, due to the fact that definitions in IEC 60601-1:2005, IEC 60601-1:2005/AMD1:2012 and IEC 60601-1:2005/AMD2:2020 are numbered 3.1 through 3.154, additional definitions in this document are numbered beginning from 201.3.201. Additional annexes are lettered AA, BB, etc., and additional items aa), bb), etc.

Subclauses, figures or tables which are additional to those of a collateral standard are numbered starting from 20x, where "x" is the number of the collateral standard, e.g. 202 for IEC 60601-1-2, 203 for IEC 60601-1-3, etc.

Where there is no corresponding clause or subclause in this particular standard, the clause or subclause of IEC 60601-1:2005, IEC 60601-1:2005/AMD1:2012 and IEC 60601-1:2005/AMD2:2020 or applicable collateral standard, although possibly not relevant, applies without modification; where it is intended that any part of IEC 60601-1:2005, IEC 60601-1:2005/AMD1:2012 and IEC 60601-1:2005/AMD2:2020 or applicable collateral standard, although possibly relevant, is not to be applied, a statement to that effect is given in this document.

201.2 Normative references

The following documents are referred to in the text in such a way that some or all of their content constitutes requirements of this document. For dated references, only the edition cited applies. For undated references, the latest edition of the referenced document (including any amendments) applies.

NOTE Informative references are listed in the Bibliography.

IEC 60601-1:2005, IEC 60601-1:2005/AMD1:2012 and IEC 60601-1:2005/AMD2:2020, Clause 2, applies except as follows:

Replacement:

IEC 60529:1989, *Degrees of protection provided by enclosures (IP Code)*
 IEC 60529:1989/AMD1:1999
 IEC 60529:1989/AMD2:2013

Addition:

IEC 60601-1:2005, *Medical electrical equipment - Part 1: General requirements for basic safety and essential performance*
 IEC 60601-1:2005/AMD1:2012
 IEC 60601-1:2005/AMD2:2020

ISO 3746, *Acoustics - Determination of sound power levels and sound energy levels of noise sources using sound pressure - Survey method using an enveloping measurement surface over a reflecting plane*

EN 597-1, *Furniture - Assessment of the ignitability of mattresses and upholstered bed bases - Part 1: Ignition source smouldering cigarette*

EN 597-2, *Furniture - Assessment of the ignitability of mattresses and upholstered bed bases - Part 2: Ignition source match-flame equivalent*

201.3 Terms and definitions

For the purposes of this document, the terms and definitions given in IEC 60601-1:2005, IEC 60601-1:2005/AMD1:2012 and IEC 60601-1:2005/AMD2:2020, and the following apply.

ISO and IEC maintain terminology databases for use in standardization at the following addresses:

- IEC Electropedia: available at <https://www.electropedia.org/>
- ISO Online browsing platform: available at <https://www.iso.org/obp>

201.3.8
APPLIED PART

Addition:

Note 4 to entry: The APPLIED PART includes all parts of the MEDICAL BED that are within the reach of the PATIENT even if they are underneath the MATTRESS SUPPORT PLATFORM.

201.3.76
PATIENT

Replacement:

living person undergoing a medical PROCEDURE or PERSON WITH DISABILITY

201.3.109
SAFE WORKING LOAD
SWL

Replacement:

sum of:

- 1) the PATIENT;
- 2) the mattress;
- 3) the ACCESSORIES of the MEDICAL BED, only if they are supported by the support system of the MEDICAL BED; and
- 4) the SAFE WORKING LOADS supported by those ACCESSORIES, excluding PATIENT weight

201.3.131
*** TRAPPING ZONE**

Replacement:

location where the PATIENT or other persons can become entrapped, entangled, wedged, or stuck in or between parts of the MEDICAL BED, such as the SIDE RAILS, HEAD BOARD, FOOT BOARD, MATTRESS SUPPORT PLATFORM or mattress

Additional terms and definitions:

201.3.201
*** APPLICATION ENVIRONMENT 1**

intensive care or critical care provided in a hospital where 24 h medical supervision and constant monitoring is required and provision of life support equipment used in medical PROCEDURES is essential to maintain or improve the vital functions of the PATIENT

201.3.202
*** APPLICATION ENVIRONMENT 2**

acute care provided in a hospital or other medical facility where medical supervision and monitoring is required and MEDICAL BED used in medical PROCEDURES is often provided to help maintain or improve the condition of the PATIENT

201.3.203
*** APPLICATION ENVIRONMENT 3**

long-term care in a medical area where medical supervision is required and monitoring is provided if necessary and MEDICAL BED used in medical PROCEDURES may be provided to help maintain or improve the condition of the PATIENT

Note 1 to entry: This includes use in nursing homes and in rehabilitation and geriatric facilities.

201.3.204

*** APPLICATION ENVIRONMENT 4**

care provided in a domestic area where MEDICAL BED is used to alleviate or compensate for an injury, disability or disease

Note 1 to entry: This excludes use in all other APPLICATION ENVIRONMENTS (e.g. nursing homes, rehabilitation and geriatric facilities) when a MEDICAL BED is purely designed for APPLICATION ENVIRONMENT 4.

201.3.205

*** APPLICATION ENVIRONMENT 5**

outpatient care or ambulatory care, which is provided in a hospital or other medical facility, under medical supervision where MEDICAL BED, is provided for the need of persons with illness, injury or disability for treatment, diagnosis or monitoring

201.3.206

*** APPLICATION ENVIRONMENT 6**

psychiatric care or mental health care environment where medical supervision is required, and monitoring is provided. MEDICAL BED used in medical PROCEDURES may be provided to help maintain, improve condition and protect the PATIENT

Note 1 to entry: Environment where a patient may be a harm to themselves or others.

Note 2 to entry: Includes prisons, jails, correctional facilities.

201.3.207

BED-LIFT

height adjustable mechanism on which a MATTRESS SUPPORT PLATFORM can be mounted

Note 1 to entry: The combination of a BED LIFT and a compatible non-MEDICAL BED as specified by the MANUFACTURER is considered to be a MEDICAL BED.

201.3.208

CHILD

PATIENT having a physical size equal to or less than 155 cm and a mass equal to or less than 70 kg and may display cognitive immaturity, exploratory behaviours, RISK-taking tendencies or any combination

Note 1 to entry: Physical size is measured from crown to sole.

[SOURCE: IEC 80601-2-89:2025[1], 201.3.207, modified – “Body length” replaced with “physical size” in the definition and in Note 1 to entry.]

201.3.209

PERSON WITH DISABILITY

person with one or more impairments, one or more activity limitations, one or more participation restrictions or a combination thereof

[SOURCE: ISO 9999:2022[3], 3.10]

201.3.210

HEAD OR FOOT BOARD

assembly mounted to a MEDICAL BED, which identifies for the PATIENT the edge of the head or foot end of either the MEDICAL BED or MATTRESS SUPPORT PLATFORM or both

Note 1 to entry: It can be used as handles to push a MEDICAL BED intended to transport PATIENTS.

201.3.211

LIFTING POLE

ACCESSORY attached to a MEDICAL BED and intended to assist support of a PATIENT when changing position by providing a gripping support above the PATIENT

201.3.212**MATTRESS OVERLAY**

supplementary mattress, which is intended to be placed on an existing mattress, and generally used for prophylactic or therapeutic effect

201.3.213**MATTRESS SUPPORT PLATFORM**

structure which supports a PATIENT surface

Note 1 to entry: The platform can articulate or change positions to facilitate various therapeutic, diagnostic and convenience positions (See Figure 201.101).

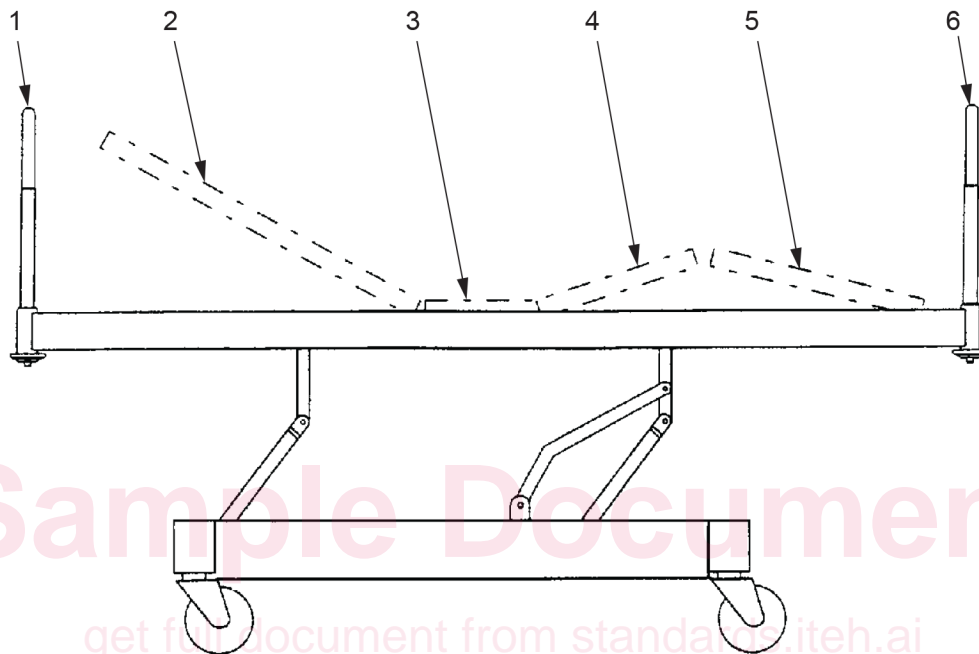

IEC

Key

- 1 HEAD BOARD
- 2 Back section (part of MATTRESS SUPPORT PLATFORM)
- 3 Seat section (part of MATTRESS SUPPORT PLATFORM)
- 4 Upper leg section (part of MATTRESS SUPPORT PLATFORM)
- 5 Lower leg section (part of MATTRESS SUPPORT PLATFORM)
- 6 FOOT BOARD

**Figure 201.101 – MEDICAL BED, general arrangement
(example, schematic presentation only)**

201.3.214*** MEDICAL BED**

device for which the INTENDED USE is sleeping, resting or both that contains a MATTRESS SUPPORT PLATFORM and intended to assist in diagnosis, monitoring, prevention, treatment, alleviation of disease or compensation for an injury or disability

201.3.215**MOTION LOCKOUT CONTROL**

auxiliary subsystem that deactivates motion controls