

# TECHNICAL REPORT

---

**Electrochemical capacitor for use in electrical energy storage**

Sample Document

get full document from [standards.iteh.ai](https://standards.iteh.ai)



**THIS PUBLICATION IS COPYRIGHT PROTECTED**  
**Copyright © 2026 IEC, Geneva, Switzerland**

All rights reserved. Unless otherwise specified, no part of this publication may be reproduced or utilized in any form or by any means, electronic or mechanical, including photocopying and microfilm, without permission in writing from either IEC or IEC's member National Committee in the country of the requester. If you have any questions about IEC copyright or have an enquiry about obtaining additional rights to this publication, please contact the address below or your local IEC member National Committee for further information.

IEC Secretariat  
3, rue de Varembe  
CH-1211 Geneva 20  
Switzerland

Tel.: +41 22 919 02 11  
[info@iec.ch](mailto:info@iec.ch)  
[www.iec.ch](http://www.iec.ch)

**About the IEC**

The International Electrotechnical Commission (IEC) is the leading global organization that prepares and publishes International Standards for all electrical, electronic and related technologies.

**About IEC publications**

The technical content of IEC publications is kept under constant review by the IEC. Please make sure that you have the latest edition, a corrigendum or an amendment might have been published.

**IEC publications search -**

[webstore.iec.ch/advsearchform](http://webstore.iec.ch/advsearchform)

The advanced search enables to find IEC publications by a variety of criteria (reference number, text, technical committee, ...). It also gives information on projects, replaced and withdrawn publications.

**IEC Just Published - [webstore.iec.ch/justpublished](http://webstore.iec.ch/justpublished)**

Stay up to date on all new IEC publications. Just Published details all new publications released. Available online and once a month by email.

**IEC Customer Service Centre - [webstore.iec.ch/csc](http://webstore.iec.ch/csc)**

If you wish to give us your feedback on this publication or need further assistance, please contact the Customer Service Centre: [sales@iec.ch](mailto:sales@iec.ch).

**IEC Products & Services Portal - [products.iec.ch](http://products.iec.ch)**

Discover our powerful search engine and read freely all the publications previews, graphical symbols and the glossary. With a subscription you will always have access to up to date content tailored to your needs.

**Electropedia - [www.electropedia.org](http://www.electropedia.org)**

The world's leading online dictionary on electrotechnology, containing more than 22 500 terminological entries in English and French, with equivalent terms in 25 additional languages. Also known as the International Electrotechnical Vocabulary (IEV) online.

**Warning! Make sure that you obtained this publication from an authorized distributor.**

## CONTENTS

FOREWORD .....	4
1 Scope .....	6
2 Normative references .....	6
3 Terms, definitions and abbreviated terms .....	6
3.1 Terms and definitions .....	6
3.2 Abbreviated terms .....	7
4 Overview of electrochemical capacitor .....	8
4.1 Classification and characteristics of electrochemical capacitor .....	8
4.1.1 Classification of electrochemical capacitor .....	8
4.1.2 Technical characteristics of electrochemical capacitor .....	9
4.2 Development of global electrochemical capacitor market .....	9
5 Application of electrochemical capacitor in EES .....	10
5.1 General .....	10
5.2 Generation side storage .....	11
5.2.1 Support the smooth integration of renewable energy into the grid .....	11
5.2.2 Coordinate with traditional power generation units for frequency regulation .....	11
5.2.3 Back-up source .....	11
5.3 Grid side storage .....	12
5.3.1 Substation frequency regulation .....	12
5.3.2 Microgrid power support .....	12
5.3.3 Distribution terminal back-up power supply .....	12
5.4 User side storage .....	13
5.5 Typical structure of electrochemical capacitor EES system .....	13
6 Testing items of electrochemical capacitor for use in EES .....	14
6.1 Testing items of electrochemical capacitor cells for use in EES .....	14
6.2 Testing items of electrochemical capacitor modules for use in EES .....	14
7 Standardization demand and roadmap for electrochemical capacitor used in EES .....	16
7.1 Necessity of developing standards for electrochemical capacitors used in EES .....	16
7.2 Current status of ISO/IEC standards related to electrochemical capacitor .....	17
7.2.1 General .....	17
7.2.2 Technical procedures for electrochemical capacitor .....	17
7.2.3 Testing procedures for electrochemical capacitor .....	18
7.2.4 Summary .....	19
7.3 Roadmap of electrochemical capacitor standardization for use in EES .....	19
7.3.1 Conception of electrochemical capacitor standard structure for use in EES .....	19
7.3.2 The development path of future standards .....	20
Annex A (informative) Application case of electrochemical capacitor EES system coupled with thermal power unit to participate in power frequency regulation .....	21
A.1 General .....	21
A.2 Introduction of electrochemical capacitor EES system .....	21
A.2.1 Technical principle .....	21
A.2.2 Composition of electrochemical capacitor EES system .....	22
A.2.3 Electrical diagram of energy storage system .....	22
A.3 Characteristics of electrochemical capacitor in the project .....	23

A.3.1	Charging-discharging characteristic curve, self-discharging characteristic curve .....	23
A.3.2	Cycle life characteristic curve .....	25
A.3.3	Energy density measurement .....	25
A.3.4	Power density measurement .....	26
A.3.5	Safety test .....	26
A.4	Application achievement .....	27
Annex B (informative)	Application case of electrochemical capacitor EES system in island distributed microgrid .....	30
B.1	General .....	30
B.2	Introduction of electrochemical capacitor EES system .....	30
B.3	Characteristics of electrochemical capacitor in the project .....	32
B.3.1	Discharging characteristics curve of 2,7 V, 3 000 F electrochemical capacitor cells .....	32
B.3.2	Discharging characteristics curve of 48 V, 165 F electrochemical capacitor modules .....	32
B.3.3	Charging and discharging characteristics curve of 500 kW×15 s electrochemical capacitor EES system .....	33
B.4	Application achievement .....	34
Annex C (informative)	Application case of electrochemical capacitor EES system in brake energy recovery .....	35
C.1	General .....	35
C.2	Technical principle .....	35
C.3	Application achievement .....	36
Annex D (informative)	Application case of electrochemical capacitor EES system in back-up source of wind power system .....	37
D.1	General .....	37
D.2	Technical principle .....	37
D.3	Application achievement .....	38
Bibliography	.....	39
Figure 1	– Classification of electrochemical capacitors .....	8
Figure 2	– Application of CESS in thermal power plant .....	11
Figure 3	– Application of CESS in substation .....	12
Figure 4	– Schematic diagram of household light storage system .....	13
Figure 5	– Schematic diagram of CESS .....	13
Figure 6	– Link between CESS and users' needs .....	16
Figure A.1	– CESS project of thermal power plant .....	21
Figure A.2	– Technical principle of CESS coupled with thermal power unit to participate in power frequency regulation .....	22
Figure A.3	– Structure diagram of electrochemical capacitor bank .....	22
Figure A.4	– Electrical diagram of CESS .....	23
Figure A.5	– Typical charging-discharging characteristics curve of 4 V/15 000 F hybrid electrochemical capacitor .....	24
Figure A.6	– Typical self-discharging characteristics curve of 4 V/15 000 F hybrid electrochemical capacitor .....	25
Figure A.7	– Cycle life characteristic curve of 4 V/15 000 F hybrid electrochemical capacitor .....	25
Figure A.8	– Safety test of 4 V/15 000 F hybrid electrochemical capacitor .....	27

Figure A.9 – Schematic diagram of frequency regulation performance improvement after CESS investment .....	28
Figure A.10 – Temperature difference between banks .....	29
Figure B.1 – CESS project of island distributed microgrid .....	30
Figure B.2 – 500 kW × 15 s CESS schematic .....	31
Figure B.3 – Structure diagram of CESS .....	32
Figure B.4 – Discharging curve of 2,7 V, 3 000 F EDLC cells .....	32
Figure B.5 – Discharging curve of 48 V, 165 F EDLC modules .....	33
Figure B.6 – Discharging curve of branch 1 in 500 kW × 15 s CESS .....	33
Figure B.7 – Charging curve of branch 1 in 500 kW × 15 s CESS .....	34
Figure C.1 – Schematic diagram of CESS braking energy recovery system .....	35
Figure D.1 – Topology diagram of wind turbine pitch control system with electrochemical capacitor energy storage as back-up source .....	38
Table 1 – Parameters of EDLCs and hybrid electrochemical capacitors .....	9
Table 2 – Testing items of electrochemical capacitor cells .....	14
Table 3 – Testing items of electrochemical capacitor modules .....	15
Table 4 – Electrochemical capacitor standard structure .....	19
Table 5 – Standard system of electrochemical capacitors for use in EES .....	20
Table A.1 – Energy density measurement results of 4 V/15 000 F hybrid electrochemical capacitor .....	26
Table A.2 – Power density measurement results of 4 V/15 000 F hybrid electrochemical capacitor .....	26
Table A.3 – Energy conversion efficiency test of CESS .....	28
Table A.4 – Energy conversion efficiency test of LIB EES system .....	28

INTERNATIONAL ELECTROTECHNICAL COMMISSION

---

**Electrochemical capacitor for use in electrical energy storage**

FOREWORD

1) The International Electrotechnical Commission (IEC) is a worldwide organization for standardization comprising all national electrotechnical committees (IEC National Committees). The object of IEC is to promote international co-operation on all questions concerning standardization in the electrical and electronic fields. To this end and in addition to other activities, IEC publishes International Standards, Technical Specifications, Technical Reports, Publicly Available Specifications (PAS) and Guides (hereafter referred to as "IEC Publication(s)"). Their preparation is entrusted to technical committees; any IEC National Committee interested in the subject dealt with may participate in this preparatory work. International, governmental and non-governmental organizations liaising with the IEC also participate in this preparation. IEC collaborates closely with the International Organization for Standardization (ISO) in accordance with conditions determined by agreement between the two organizations.

2) The formal decisions or agreements of IEC on technical matters express, as nearly as possible, an international consensus of opinion on the relevant subjects since each technical committee has representation from all interested IEC National Committees.

3) IEC Publications have the form of recommendations for international use and are accepted by IEC National Committees in that sense. While all reasonable efforts are made to ensure that the technical content of IEC Publications is accurate, IEC cannot be held responsible for the way in which they are used or for any misinterpretation by any end user.

4) In order to promote international uniformity, IEC National Committees undertake to apply IEC Publications transparently to the maximum extent possible in their national and regional publications. Any divergence between any IEC Publication and the corresponding national or regional publication shall be clearly indicated in the latter.

5) IEC itself does not provide any attestation of conformity. Independent certification bodies provide conformity assessment services and, in some areas, access to IEC marks of conformity. IEC is not responsible for any services carried out by independent certification bodies.

6) All users should ensure that they have the latest edition of this publication.

7) No liability shall attach to IEC or its directors, employees, servants or agents including individual experts and members of its technical committees and IEC National Committees for any personal injury, property damage or other damage of any nature whatsoever, whether direct or indirect, or for costs (including legal fees) and expenses arising out of the publication, use of, or reliance upon, this IEC Publication or any other IEC Publications.

8) Attention is drawn to the Normative references cited in this publication. Use of the referenced publications is indispensable for the correct application of this publication.

9) IEC draws attention to the possibility that the implementation of this document may involve the use of (a) patent(s). IEC takes no position concerning the evidence, validity or applicability of any claimed patent rights in respect thereof. As of the date of publication of this document, IEC had not received notice of (a) patent(s), which may be required to implement this document. However, implementers are cautioned that this may not represent the latest information, which may be obtained from the patent database available at <https://patents.iec.ch>. IEC shall not be held responsible for identifying any or all such patent rights.

IEC 63650 has been prepared by IEC technical committee 40: Capacitors and resistors for electronic equipment. It is a Technical Report.

The text of this Technical Report is based on the following documents:

Draft	Report on voting
40/3294/DTR	40/3312/RVDTR

Full information on the voting for its approval can be found in the report on voting indicated in the above table.

The language used for the development of this Technical Report is English.

This document was drafted in accordance with ISO/IEC Directives, Part 2, and developed in accordance with ISO/IEC Directives, Part 1 and ISO/IEC Directives, IEC Supplement, available at [www.iec.ch/members\\_experts/refdocs](http://www.iec.ch/members_experts/refdocs). The main document types developed by IEC are described in greater detail at [www.iec.ch/publications](http://www.iec.ch/publications).

The committee has decided that the contents of this document will remain unchanged until the stability date indicated on the IEC website under [webstore.iec.ch](http://webstore.iec.ch) in the data related to the specific document. At this date, the document will be

- reconfirmed,
- withdrawn, or
- revised.

# Sample Document

get full document from [standards.iteh.ai](http://standards.iteh.ai)

## 1 Scope

This technical report investigates the primary technological approaches, current applications, and development prospects of electrochemical capacitors (supercapacitors). In particular, this document also analyses the technical solutions and characteristics of electrochemical capacitor applications in the field of Electrical Energy Storage (EES) and provides representative application cases. Then, the testing items of the electrochemical capacitors for use in EES are introduced for the cells and modules, respectively.

By collecting the existing standards of electrochemical capacitor, this document identifies the gap between the existing IEC and ISO standards and the actual needs of electrochemical capacitors used in EES and proposes descriptions and a roadmap for future standardization of electrochemical capacitors in the field of EES. This work will promote the rapid progress and broader applications of electrochemical capacitors in the field of EES.

## 2 Normative references

There are no normative references in this document.

## 3 Terms, definitions and abbreviated terms

### 3.1 Terms and definitions

For the purposes of this document, the following terms and definitions apply.

ISO and IEC maintain terminology databases for use in standardization at the following addresses:

- IEC Electropedia: available at <https://www.electropedia.org/>
- ISO Online browsing platform: available at <https://www.iso.org/obp>

#### 3.1.1

##### **electrochemical capacitor supercapacitor**

device that stores electrical energy using a double layer in an electrochemical cell

Note 1 to entry: An electrochemical capacitor, at least one electrode primarily stores energy through a double-layer capacitance formed at the electrode and electrolyte interface. The relationship curve between time and voltage during constant current charging or discharging is usually approximately linear.

Note 2 to entry: The electrochemical capacitor is not to be confused with electrolytic capacitors (IEC 60050-114:2014 [1], 114-03-04).

[SOURCE: IEC 60050-114:2014 [1], 114-03-03, modified — Note 1 to entry has been added.]

#### 3.1.2

##### **electric double-layer capacitor**

device that stores electrical energy using a double layer in an electrochemical cell, and whose positive and negative electrodes are of the same material

Note 1 to entry: The electrolytic capacitor is not included in capacitor of this document.

[SOURCE: IEC 62576:2018 [2], 3.13]

**3.1.3****hybrid electrochemical capacitor**

capacitor that uses an electric double-layer on one electrode and a Faradaic reaction on the other to store electrical energy

Note 1 to entry: A faradaic reaction is an electrochemical reaction involving the transfer of electrons including redox reaction and doping and undoping reaction.

**3.1.4****energy efficiency**

ratio of discharging energy to charging energy of an electrochemical capacitor under specified test conditions and test methods, expressed as a percentage

**3.1.5****retention rate of energy**

ratio (%) of charging energy and discharging energy to its initial charging energy and initial discharging energy of an electrochemical capacitor respectively, under specified test conditions and test methods

**3.1.6****recovery rate of energy**

ratio (%) of the charging energy and discharging energy to the initial charging energy and initial discharging energy after storage or open-circuit standing of an electrochemical capacitor, respectively, under specified test conditions and test methods

**3.1.7****range**

measure of variability in statistical data, which is the difference between the maximum and minimum values, i.e., the numerical result obtained by subtracting the minimum value from the maximum value

**3.1.8****fire**

continuous combustion lasting more than 1 s that occurs in any part of the electrochemical capacitor

Note 1 to entry: Sparks and arcs are not considered combustion.

**3.1.9****explosion**

rupture of the electrochemical capacitor casing with a loud noise and is accompanied by the ejection of solid materials, including its main components (excluding the normal opening of safety valves)

**3.1.10****leakage**

unplanned escape of electrolyte, gas or other material from a cell or electrochemical capacitor

**3.2 Abbreviated terms**

For the purposes of this document, the following abbreviated terms apply.

AGC	Automatic generation control
CESS	Capacitor energy storage system
CMS	Capacitor management system
DOD	Depth of discharge
EDLC	Electric double-layer capacitor
EES	Electrical energy storage

EMS	Energy management system
LIB	Lithium-ion battery
LIC	Lithium-ion capacitor
PCS	Power conversion system
SIC	Sodium-ion capacitor
SOC	State of charge

## 4 Overview of electrochemical capacitor

### 4.1 Classification and characteristics of electrochemical capacitor

#### 4.1.1 Classification of electrochemical capacitor

Electrochemical capacitor is an electrochemical energy storage capacitor, at least one electrode primarily stores energy through a double-layer capacitance formed at the electrode and electrolyte interface. The relationship curve between time and voltage during constant current charging or discharging is usually approximately linear.

According to energy storage mechanisms, electrochemical capacitors can be categorized as EDLCs and hybrid electrochemical capacitor, as shown in Figure 1.

EDLCs store electrical energy using a double layer in an electrochemical cell, and whose positive and negative electrodes are of the same material. EDLCs are primarily composed of carbon materials such as activated carbon, graphene, and carbon nanotubes as electrode materials, without Faradaic reaction, and are widely used in wind turbine pitch control system, transportation, energy recovery, consumer electronics and power fluctuation suppression, etc.

Hybrid electrochemical capacitors use an electric double-layer on one electrode and a Faradaic reaction on the other to store electrical energy. Hybrid electrochemical capacitors primarily include LICs and SICs, among which LICs have been widely used in large-capacity energy storage scenarios such as rail transit, primary power frequency regulation, secondary power frequency regulation, etc.

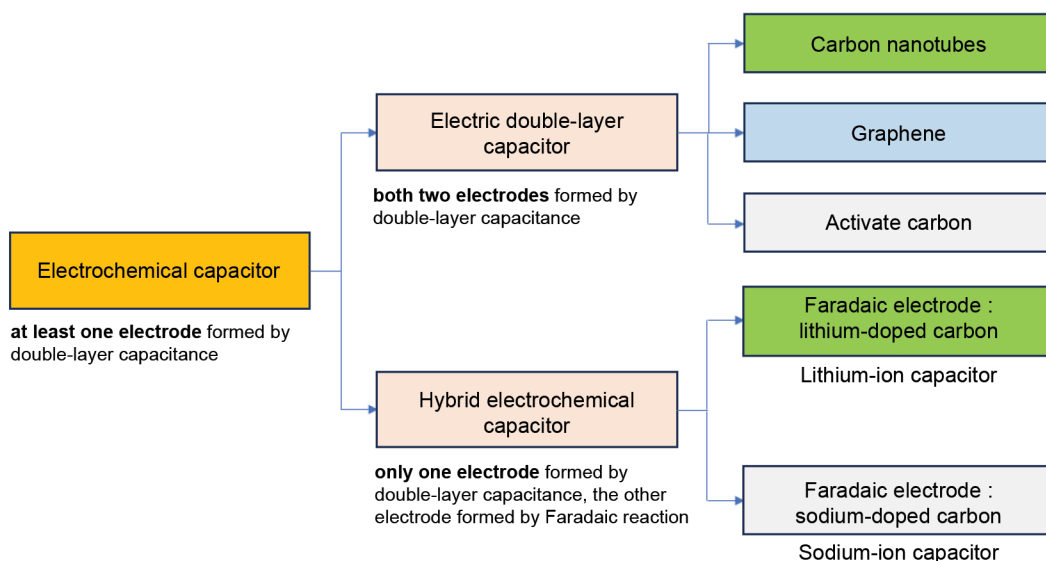

IEC

Figure 1 – Classification of electrochemical capacitors

#### 4.1.2 Technical characteristics of electrochemical capacitor

Compared to conventional secondary batteries, the technical characteristics of electrochemical capacitor have the following advantages.

- a) High power density. Electrochemical capacitors enable rapid energy storage and release, with power outputs of up to 10 kW/kg or more, because the energy storage process in electrochemical capacitors occurs at the surface of the electrode material and is less constrained by the rate of ion diffusion.
- b) Fast charging and discharging speed. Electrochemical capacitors can usually be charged and discharged to more than 95 % of their rated capacity in 10 s to 10 min, due to the charging and discharging process of electrochemical capacitors is basically a surface electrochemical process.
- c) Long cycle life. EDLCs have excellent reversibility of charging and discharging because they do not involve Faradaic reactions, and their cycle life can reach  $5 \times 10^5$  times to  $1 \times 10^6$  times. Hybrid electrochemical capacitors can also have a cycle life of  $5 \times 10^5$  to  $1 \times 10^6$  times.
- d) Large working voltage range. The operating voltage of the electrochemical capacitors can be arbitrarily changed within its rated voltage range.
- e) Wide operating temperature range. Electrochemical capacitors can be used normally at ambient temperatures of  $-40 \text{ }^\circ\text{C}$  to  $70 \text{ }^\circ\text{C}$ , and have excellent low temperature characteristics, which can achieve low maintenance by reducing the number of auxiliary devices such as temperature control equipment.

The main technical parameters of EDLCs and hybrid electrochemical capacitors are shown in Table 1.

**Table 1 – Parameters of EDLCs and hybrid electrochemical capacitors**

Parameters	EDLC	Hybrid electrochemical capacitor
Energy density	1,5 Wh/kg to 8 Wh/kg	20 Wh/kg to 80 Wh/kg
Power density	5 kW/kg to 50 kW/kg	5 kW/kg to 50 kW/kg
Temperature range	$-40 \text{ }^\circ\text{C}$ to $+70 \text{ }^\circ\text{C}$	$-40 \text{ }^\circ\text{C}$ to $+70 \text{ }^\circ\text{C}$
Charging and discharging cycles	$5 \times 10^5$ to $1 \times 10^6$	$5 \times 10^5$ to $1 \times 10^6$
Lifetime	>10 years	>10 years

#### 4.2 Development of global electrochemical capacitor market

In recent years, the global electrochemical capacitor market has shown rapid growth. According to incomplete statistics from the Supercapacitor Industry Alliance, the global electrochemical capacitor market size (taking components as the statistical object) was USD  $1,38 \times 10^9$  in 2020. In 2021, the global electrochemical capacitor market size (measured by components) reached USD  $1,59 \times 10^9$ , representing a year-on-year growth of 15,2 %. The increasing demand in sectors such as wind power generation, consumer electronics, EES and industrial applications is the main driver of the growth in the electrochemical capacitor market.

Electrochemical capacitors are widely used in various fields such as new energy, grid equipment, transportation, consumer electronics, and industry, etc. In 2021, the highest market share for electrochemical capacitors was in the new energy sector, accounting for approximately 35,2 %. Transportation and industrial markets followed with shares of 18,8 % and 14,6 %, respectively. Grid equipment and consumer electronics also had significant market shares at 10,5 % and 8,5 %, respectively. The combined share of other application areas was 13,4 %.

Undoubtedly, the strong demand for component products will drive significant growth across the entire industry chain, including electrode materials, electrolytes, separators, current collectors, auxiliary materials, various manufacturing equipment and control systems, analysis and testing instruments, safety equipment, system integration, and power management and other technology development and basic research, as well as software, patents, analysis, testing, and standardization, industry analysis, investment services and other technical service system.

In addition, with the continuous deepening of the transformation of green and low-carbon energy, the proportion of renewable energy connected to the grid is constantly increasing, and the demand for the regulating of power quality is growing day by day. Electrochemical capacitors, as short-term high-power energy storage devices, are very suitable for power grid frequency regulation. In 2021, the sales of electrochemical capacitors in the power field began to grow more than 5 times. However, the current application of megawatt-level electrochemical capacitor systems applied in the power industry, such as independent energy storage frequency regulation project, grid-forming energy storage project, still have a competitive disadvantage in terms of cost compared to other high-power energy storage technologies. The industry still needs to make continuous efforts in technology, market, and other aspects.

## 5 Application of electrochemical capacitor in EES

### 5.1 General

Electrochemical capacitors have become an indispensable energy storage technology in EES due to their outstanding electrical characteristics, ultra-long cycling life, good environmental adaptability, and high levels of safety and stability compared to conventional secondary batteries.

According to differentiation of energy storage time, EDLCs primarily undertake power compensation tasks in the range of seconds to 5 min, which is mainly used in the application of backup power, primary frequency regulation and instantaneous power fluctuation suppression, etc. The hybrid electrochemical capacitor mainly undertake power compensation tasks in the range of 5 min to 15 min, which is mainly used in primary and secondary frequency regulation and other applications.

According to the operation form, the electrochemical CESS includes two types: coupling form and independent form. The independent form mainly refers to the independent energy storage power station used for power frequency regulation or power quality improvement or refers to the independent back-up power supply (such as wind turbine pitch control system, etc.) used to improve the power supply reliability of important equipment. The coupling form mainly refers to the CESS to assist the power coordination of the generator unit to achieve power frequency regulation or power quality improvement.

On the generation side, electrochemical capacitors are mainly used to cooperate with traditional energy sources, participate in power frequency regulation and smooth the fluctuation of renewable energy output. On the grid side, electrochemical capacitors are used for power compensation, thereby enhancing grid reliability. On the user side, the electrochemical capacitors can be used as back-up source to provide emergency power supply and reduce the cost of electricity consumption.