

INTERNATIONAL
STANDARD

ISO
11055

First edition
1996-12-15

**Flywheels for reciprocating internal
combustion engines — Installation
dimensions for clutches**

Sample Document

*Volant moteur pour moteur alternatif à combustion interne — Dimensions
d'installation des embrayages*

get full document from standards.iteh.ai



Reference number
ISO 11055:1996(E)

Foreword

ISO (the International Organization for Standardization) is a worldwide federation of national standards bodies (ISO member bodies). The work of preparing International Standards is normally carried out through ISO technical committees. Each member body interested in a subject for which a technical committee has been established has the right to be represented on that committee. International organizations, governmental and non-governmental, in liaison with ISO, also take part in the work. ISO collaborates closely with the International Electrotechnical Commission (IEC) on all matters of electrotechnical standardization.

Draft International Standards adopted by the technical committees are circulated to the member bodies for voting. Publication as an International Standard requires approval by at least 75 % of the member bodies casting a vote.

International Standard ISO 11055 was prepared by Technical Committee ISO/TC 22, *Road vehicles*, Subcommittee SC 15, *Interchangeability of components of commercial vehicles and buses*.

Annex A of this International Standard is for information only.

© ISO 1996

All rights reserved. Unless otherwise specified, no part of this publication may be reproduced or utilized in any form or by any means, electronic or mechanical, including photocopying and microfilm, without permission in writing from the publisher.

International Organization for Standardization
Case Postale 56 • CH-1211 Genève 20 • Switzerland

Printed in Switzerland

Flywheels for reciprocating internal combustion engines — Installation dimensions for clutches

1 Scope

This International Standard specifies the nominal dimensions and tolerances which affect the interchangeability between flywheels and spring-loaded single- or two-plate clutches.

The flywheels are for use on reciprocating internal combustion engines in conjunction with flywheel housings and clutch housings which are dealt with in ISO 7648^[1] and ISO 7649^[2].

Dimensions and tolerances not specified are left to the discretion of the component manufacturer.

This International Standard applies to reciprocating internal combustion engines, with the exception of engines for aircraft and passenger cars; it may be used for other engine applications where no specific International Standard exists.

NOTE — It is recognized that the dimensions shown in this International Standard may not be suitable for some designs in use at present, but they should be used for all new designs as a means of achieving rationalization in the future.

2 Normative references

The following standards contain provisions which, through reference in this text, constitute provisions of this International Standard. At the time of publication, the editions indicated were valid. All standards are subject to revision, and parties to agreements based on this International Standard are encouraged to investigate the possibility of applying the most recent editions of the standards indicated below. Members of IEC and ISO maintain registers of currently valid International Standards.

ISO 286-2:1988, *ISO system of limits and fits — Part 2: Tables of standard tolerance grades and limit deviations for holes and shafts*.

ISO 1101:1983, *Technical drawings — Geometrical tolerancing — Tolerancing of form, orientation, location and run-out — Generalities, definitions, symbols, indications on drawings*.

3 Flywheel types and specifications

This International Standard defines two types of flywheel:

- flat type [see figure 1 a)];
- pot type [see figure 1 b)].

Both types are specified for clutch centring either by spigot or dowels. Dowel holes are specified on the same pitch circle diameter as tapped holes.

For dimensions and tolerances in figure 1, see tables 1 and 2. For definitions and symbols for geometrical tolerances, see ISO 1101.

4 Tapped holes and dowels

Any variation in tapped hole or dowel pattern and/or size shall be subject to agreement between engine manufacturers and clutch suppliers, including the eventuality of stepped dowels being required.

Dimensions in millimetres

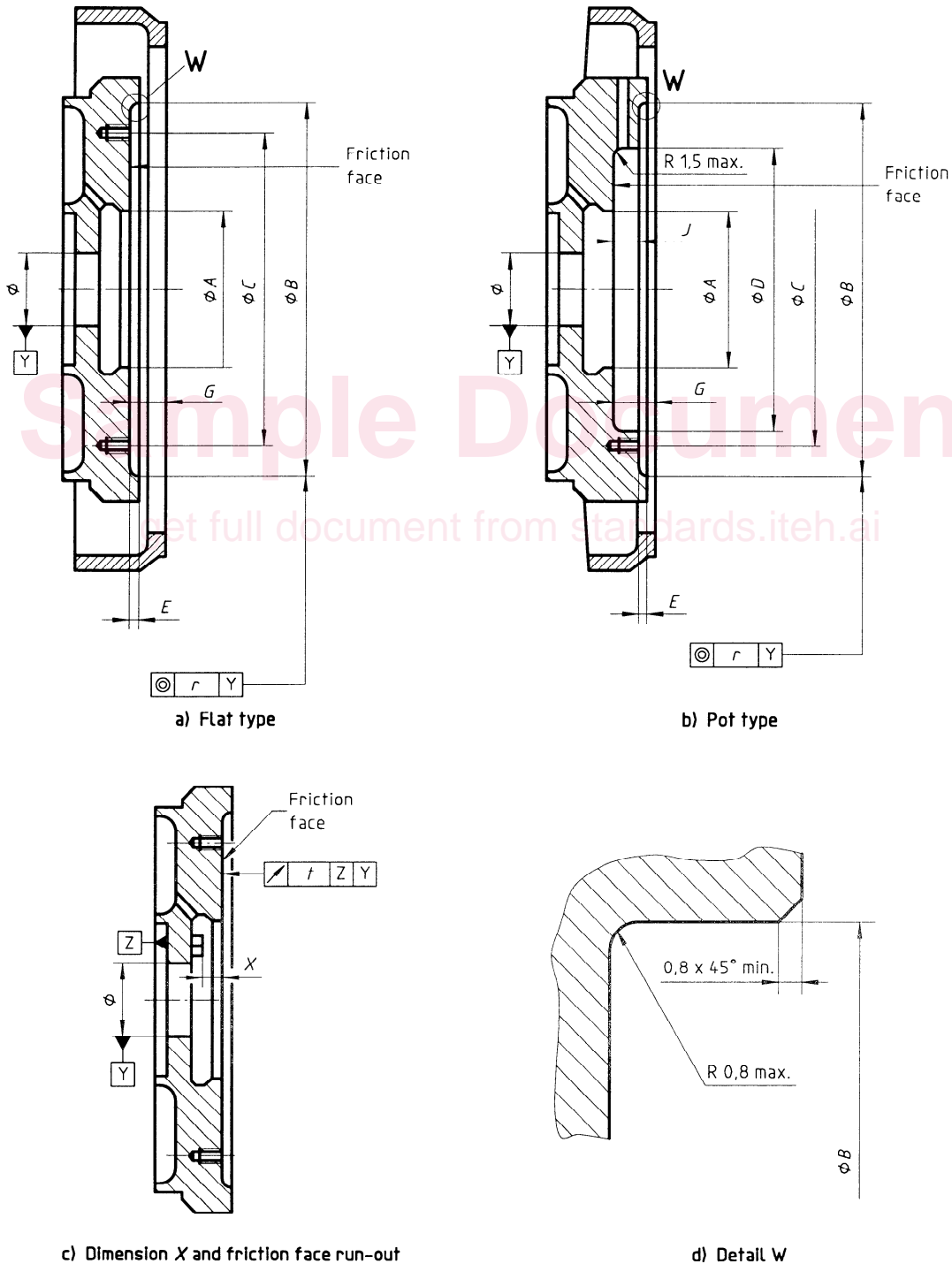

Figure 1 — Flywheels

Table 1 — Flywheels for single-plate clutches — Flat and pot types

Dimensions in millimetres

Sizes by type designation	A ¹⁾	B ²⁾ + 0,08 0	C	D	E	Tapped holes		Dowels		G ³⁾ nom.	J ⁴⁾	X ³⁾⁵⁾ min.	t	r
						No.	L	No.	For position, see figure h8 6)					
250	165	310	290			6		2						0,159
265	165	325	305			6		2	3			8		0,166
280	175	340	320	—	5	6	M8	2	8		—	8		0,174
310	185	365	345			12		4				10		0,189
330	195	390	370			12		4				12		0,2
350	200	395	375	360	6		M8		2, 3 or 4	66,5	38	14		0,205
380	200 ⁷⁾	435 ⁸⁾	410 ⁸⁾	390	6		M10		10		40	16		0,22
395	215	435	410	405	6	12	M10	4 or 5	10		40	16		0,23
400	215 ¹⁰⁾	450	418	—	8		M10		—		—	18		0,23
430	235 ¹¹⁾	475	450	440	8		M10		2, 3 or 4		40	18		0,245

1) Dimension A is for guidance only and will depend on future development.

2) Dimension B applies only when a spigot location is required. It does not apply when dowels are used for location purposes.

3) In certain cases, depending on the position of the release bearing, dimension G can be reduced, subject to agreement between engine manufacturer and clutch supplier; this question will be considered in the future. Also, depending upon the design of the clutch torsional damper, dimension X min. can be increased or reduced, subject to agreement between engine manufacturer and clutch supplier; this question will also be considered in the future.

4) Dimension J can be 48 mm for size designation 430.

5) The X min. dimension is given for guidance and is intended to ensure clearance between the clutch torsional damper in the fully worn condition of the driven plate and the heads of the flywheel/crankshaft fixing screws. As the PCD (Pitch Circle Diameter) of the latter is not specified and there are no envelope dimensions stated for clutches, this dimension permits installation and subsequent clutch plate wear without fouling.

6) See ISO 286-2.

7) 215 for engine torques above 750 N·m.

8) These dimensions are reduced when using flywheel housing size code 3 with cast iron clutch covers.

9) $r = \frac{0,013D'}{25,4}$

where, D' is the diameter of measurements:
 — for figure 1 a), D' is between A and B;
 — for figure 1 b), D' is between D and B.

10) 235 for engine torques above 1 200 N·m.
 11) 258 for engine torques above 2 200 N·m.