



**International
Standard**

ISO 13503-9

**Oil and gas industries including
lower carbon energy — Completion
fluids and materials —**

**Part 9:
Methods for evaluating
performance of acidizing fluids**

*Industries du pétrole et du gaz, y compris les énergies à faible
teneur en carbone — Fluides de complétion et matériaux —*

*Partie 9: Méthodes d'évaluation des performances des fluides
acidifiants*

**First edition
2026-04**

Sample Document

get full document from standards.iteh.ai



COPYRIGHT PROTECTED DOCUMENT

© ISO 2026

All rights reserved. Unless otherwise specified, or required in the context of its implementation, no part of this publication may be reproduced or utilized otherwise in any form or by any means, electronic or mechanical, including photocopying, or posting on the internet or an intranet, without prior written permission. Permission can be requested from either ISO at the address below or ISO's member body in the country of the requester.

ISO copyright office
CP 401 • Ch. de Blandonnet 8
CH-1214 Vernier, Geneva
Phone: +41 22 749 01 11
Email: copyright@iso.org
Website: www.iso.org

Published in Switzerland

Contents

	Page
Foreword.....	v
1 Scope	1
2 Normative references	1
3 Terms and definitions	1
4 Principle	2
5 Hydrochloric acid acidizing fluid system	3
5.1 Corrosion rate assessment.....	3
5.1.1 Purpose.....	3
5.1.2 General.....	3
5.1.3 Reagents and materials.....	3
5.1.4 Apparatus.....	4
5.1.5 Preparation and preservation of test samples and pieces.....	6
5.1.6 Static corrosion rate test procedure.....	7
5.1.7 Dynamic corrosion rate test procedure.....	7
5.1.8 Calculation.....	8
5.2 Acid rock reaction rate.....	8
5.2.1 Purpose.....	8
5.2.2 General.....	9
5.2.3 Reagents and materials.....	9
5.2.4 Apparatus.....	9
5.2.5 Preparation and preservation of test samples and test pieces.....	9
5.2.6 Acid rock reaction rate test procedure.....	10
5.2.7 Calculation.....	11
5.2.8 Plotting the curve.....	11
5.3 Dissolution rate.....	12
5.3.1 Purpose.....	12
5.3.2 General.....	12
5.3.3 Reagents and materials.....	12
5.3.4 Apparatus.....	12
5.3.5 Preparation and preservation of test samples and test pieces.....	12
5.3.6 Dissolution rate test procedure.....	13
5.3.7 Calculation.....	14
5.4 Ability to stabilize ferric ion (Fe ³⁺).....	14
5.4.1 Purpose.....	14
5.4.2 General.....	14
5.4.3 Reagents and materials.....	14
5.4.4 Apparatus.....	14
5.4.5 Preparation and preservation of test samples and test pieces.....	15
5.4.6 Procedure.....	16
5.4.7 Calculation.....	17
5.5 Surface tension.....	17
5.5.1 Purpose.....	17
5.5.2 General.....	17
5.5.3 Reagents and materials.....	17
5.5.4 Apparatus.....	17
5.5.5 Preparation and preservation of test samples and test pieces.....	18
5.5.6 Surface tension measurement procedure.....	18
5.6 Interfacial tension.....	21
5.6.1 Purpose.....	21
5.6.2 General.....	21
5.6.3 Reagents and materials.....	21
5.6.4 Apparatus.....	21
5.6.5 Preparation and preservation of test samples and test pieces.....	22
5.6.6 Interfacial tension measurement procedure.....	22

5.6.7	Calculation	23
6	Mud acid acidizing fluid system	23
7	Polymer-based acid acidizing fluid system	24
8	Emulsified acid acidizing fluid system	24
9	Organic acid acidizing fluid system	24
10	Other acidizing fluid system	24
11	Test report	24
	Annex A (informative) Mud acid acidizing fluid system performance evaluation method	25
	Annex B (informative) Polymer-based acid acidizing fluid system performance evaluation method	29
	Annex C (informative) Emulsified acid acidizing fluid system performance evaluation method	34
	Bibliography	36

Sample Document

get full document from standards.iteh.ai

Foreword

ISO (the International Organization for Standardization) is a worldwide federation of national standards bodies (ISO member bodies). The work of preparing International Standards is normally carried out through ISO technical committees. Each member body interested in a subject for which a technical committee has been established has the right to be represented on that committee. International organizations, governmental and non-governmental, in liaison with ISO, also take part in the work. ISO collaborates closely with the International Electrotechnical Commission (IEC) on all matters of electrotechnical standardization.

The procedures used to develop this document and those intended for its further maintenance are described in the ISO/IEC Directives, Part 1. In particular, the different approval criteria needed for the different types of ISO documents should be noted. This document was drafted in accordance with the editorial rules of the ISO/IEC Directives, Part 2 (see www.iso.org/directives).

ISO draws attention to the possibility that the implementation of this document may involve the use of (a) patent(s). ISO takes no position concerning the evidence, validity or applicability of any claimed patent rights in respect thereof. As of the date of publication of this document, ISO had not received notice of (a) patent(s) which may be required to implement this document. However, implementers are cautioned that this may not represent the latest information, which may be obtained from the patent database available at www.iso.org/patents. ISO shall not be held responsible for identifying any or all such patent rights.

Any trade name used in this document is information given for the convenience of users and does not constitute an endorsement.

For an explanation of the voluntary nature of standards, the meaning of ISO specific terms and expressions related to conformity assessment, as well as information about ISO's adherence to the World Trade Organization (WTO) principles in the Technical Barriers to Trade (TBT), see www.iso.org/iso/foreword.html.

This document was prepared by Technical Committee ISO/TC 67, *Oil and gas industries including lower carbon energy*, Subcommittee SC 3, *Drilling and completion fluids, well cements and treatment fluids*.

A list of all parts in the ISO 13503 series can be found on the ISO website.

Any feedback or questions on this document should be directed to the user's national standards body. A complete listing of these bodies can be found at www.iso.org/members.html.

Sample Document

get full document from standards.iteh.ai

Oil and gas industries including lower carbon energy — Completion fluids and materials —

Part 9: Methods for evaluating performance of acidizing fluids

1 Scope

This document specifies the performance test procedures for acidizing fluids used as completion fluids and materials in oil and gas well operations.

NOTE The acidizing fluids mentioned in this document refer to hydrochloric acid, mud acid, polymer-based acid acidizing fluids, emulsified acid acidizing fluids, etc., used in acidizing operations of oil and gas wells, including fundamental acid solution and acidizing fluid system with additives, such as corrosion inhibitor and ferric ion (Fe^{3+}) stabilizing agent.

2 Normative references

The following documents are referred to in the text in such a way that some or all of their content constitutes requirements of this document. For dated references, only the edition cited applies. For undated references, the latest edition of the referenced document (including any amendments) applies.

ISO 3310-1:2016, *Test sieves — Technical requirements and testing — Part 1: Test sieves of metal wire cloth*

3 Terms and definitions

For the purposes of this document, the following terms and definitions apply.

ISO and IEC maintain terminology databases for use in standardization at the following addresses:

- ISO Online browsing platform: available at <https://www.iso.org/obp>
- IEC Electropedia: available at <https://www.electropedia.org/>

3.1 fundamental acid solution

solution composed of acid and water with no other additives

3.2 hydrochloric acid acidizing fluid system

hydrochloric acid mixed with functional additives to enhance its operational performance in specific industrial applications, which is used to stimulate carbonate formations

3.3 mud acid acidizing fluid system

mixture of hydrofluoric acid, functional additives and water in certain concentration, which is used to acidify sandstone reservoirs

3.4 polymer-thickened acid acidizing fluid system

acid system mixed with polymer to reduce friction, retard acid-rock reaction and uniform acid distribution

3.5

polymer-crosslinked acid acidizing fluid system

polymer-thickened acid acidizing fluid system (3.4) mixed with crosslinking agent to further enhance system viscosity

3.6

emulsified acid acidizing fluid system

emulsified fluid system composed of acid-phase mixed with functional additives and another immiscible phase

3.7

organic acid acidizing fluid system

organic acids mixed with functional additives

4 Principle

In the test methods, the test conditions, acidizing fluid systems preparation and formulations shall be specified by the supplier or entrusting party. If not specified, the operations shall be performed in accordance with the methods specified in this document.

The following safety precautions shall be implemented:

- a) Wear appropriate personal protective equipment, such as acid-resistant gloves, goggles, full face toxic gas mask and clothing, to avoid acid contact with skin and eyes.
- b) Carry out acidizing fluid systems preparation in a well-ventilated environment to avoid the accumulation and inhalation of volatile gases.
- c) Strictly follow the operating procedures, add acid to water instead of adding water to acid, and stir continuously to prevent local overheating or acid splashing.
- d) Containers, tools etc. used for preparation shall be made of acid-resistant and corrosion-resistant materials to avoid acid leakage.
- e) In case of acid leakage or contact with human body, timely treatment shall be carried out with emergency treatment equipment, such as eyewash stations, shower devices and alkaline substances for neutralization (e.g. baking soda).
- f) Once the acid contact with skin, immediately flush the skin with water for more than 15 minutes, apply calcium gluconate gel and seek medical advice.
- g) Equip with a dedicated eyewash, shower device, and 2,5 % calcium gluconate solution.
- h) Usage of glass containers is prohibited, use plastic containers such as polytetrafluoroethylene (PTFE) and polyethylene (PE) instead. Metal components shall be made of hydrofluoric acid-resistant alloys.
- i) When connecting cables to experimental related equipment such as displacement pumps and pressure sensors, ensure that the instruments are turned off.
- j) After the experiment, timely clean the pipelines and containers that have contacted with the acidizing fluid system to avoid corrosion of the residual liquid.
- k) The experimental area shall be well ventilated, especially when using volatile substances such as acidizing fluid systems. Ventilation equipment shall be turned on to avoid the accumulation of harmful gas.

5 Hydrochloric acid acidizing fluid system

5.1 Corrosion rate assessment

5.1.1 Purpose

The purpose of the corrosion rate test is to evaluate the damage degree of downhole metal materials exposed in acid during acid treatment.

5.1.2 General

The acidizing fluid system has serious corrosion to tubing, casing, downhole tools etc. The corrosion rate test is to measure the corrosion rate and pitting index of acidizing fluid systems on metal coupons, at a specific temperature and exposure time.

5.1.3 Reagents and materials

5.1.3.1 Hydrochloric acid (HCl, 36,46 g/mol, CAS-No[®]1): 7647-01-0).

5.1.3.2 Trichloroethylene (C₂HCl₃, 131,39 g/mol, CAS-No[®]: 79-01-6).

5.1.3.3 Sodium bicarbonate (NaHCO₃, 84,01 g/mol, CAS-No[®]: 144-55-8).

5.1.3.4 Acetone (C₃H₆O, 58,08 g/mol, CAS-No[®]: 67-64-1).

5.1.3.5 Methanol (CH₃OH, 32,04 g/mol, CAS-No[®]: 67-56-1).

5.1.3.6 Diethyl ether (C₄H₁₀O, 74,12 g/mol, CAS-No[®]: 60-29-7).

1) CAS Registry Number[®] is a trademark of the American Chemical Society (ACS). This information is given for the convenience of users of this document and does not constitute an endorsement of the product by ISO of the product named. Equivalent products may be used if they can lead to the same results.

5.1.4 Apparatus

5.1.4.1 High-temperature and high-pressure testing corrosion apparatus, as shown in [Figure 1](#).

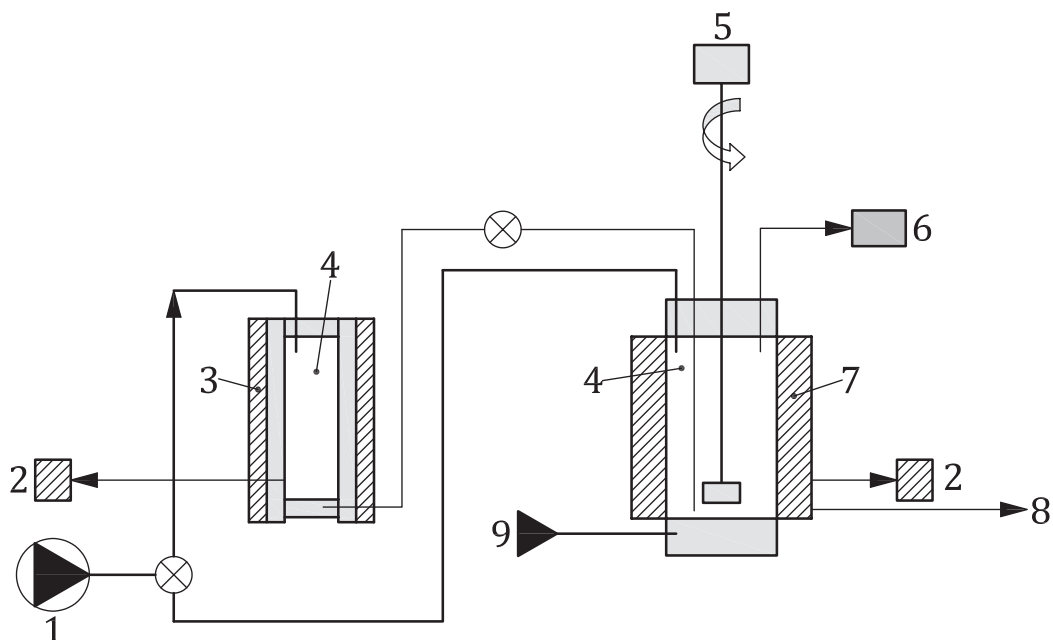

Key

- 1 pump
- 2 temperature sensor
- 3 preheating kettle
- 4 pressure relief port
- 5 rotor motor
- 6 pressure sensor
- 7 reaction kettle
- 8 sampling port
- 9 safety valve
- 10 sample holder

Figure 1 — High-temperature and high-pressure testing corrosion apparatus

- a) [Figure 1](#) is only a schematic diagram. ASTM G111-21 contains requirements for the design and manufacture of the instruments.
- b) When heating the whole system set, the cooling circulating water system shall be running in order to protect the rotor motor.
- c) During the experimental process, if there is any leaking, stop the test immediately, unload the system pressure, retighten the leaked part, and restart the test.
- d) When using pump to pressurize, check the liquid level of the pump to avoid abnormal system operation due to insufficient liquid.
- e) During the process of filling test liquid, spilling of the test liquid from either the preheating kettle or reaction kettle is strictly prohibited.
- f) When closing the lid of the preheating kettle and the reaction kettle, the lid shall be tightened and then rotated 1/4 turn in the opposite direction.
- g) When cleaning the corrosive liquid, pay attention to the recovery of waste liquid to avoid polluting the environment.

ISO 13503-9:2026(en)

- h) The instrument shall be maintained properly and periodically. Maintenance shall be carried out once a week, with each session lasting for half a day.
- i) Metal coupons, the metal coupon dimensions are specified as: 30 mm wide × 15 mm long × 3,6 mm thick with a 5 mm-diameter hole drilled through the centre.

The metal coupons are shown in [Figure 2](#).

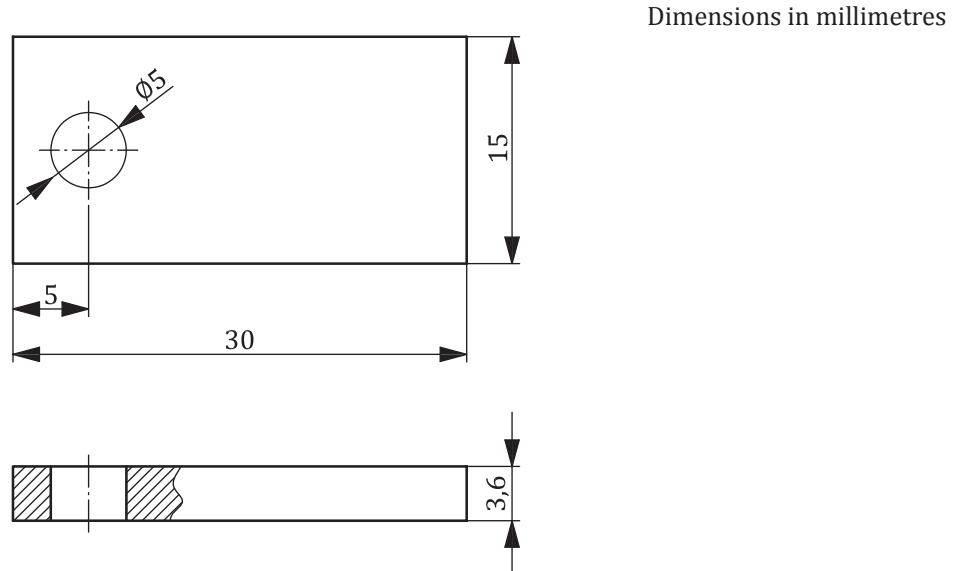

Figure 2 — Metal coupons parameters

- 5.1.4.2 Electronic balances, with a precision of 0,000 1 g to 0,01 g.
- 5.1.4.3 Stirrer.
- 5.1.4.4 Stopwatches, with an accuracy of $\pm 0,1$ s.
- 5.1.4.5 Dryer.
- 5.1.4.6 Electric blast drying oven, capable of being controlled at $100\text{ °C} \pm 1\text{ °C}$.
- 5.1.4.7 Electric blast drying ovens, with a temperature control range of $100\text{ °C} \pm 1\text{ °C}$.
- 5.1.4.8 Measuring cylinders, with capacities of 100 ml and 500 ml.
- 5.1.4.9 Beakers, with capacities of 250 ml and 1 000 ml.
- 5.1.4.10 Glass jars, with a capacity of 500 ml.
- 5.1.4.11 PTFE bottles, with a capacity of 500 ml.
- 5.1.4.12 Abrasive paper, 120-grit.

5.1.5 Preparation and preservation of test samples and pieces

5.1.5.1 Hydrochloric acid acidizing fluid system preparation

a) Hydrochloric acid solution preparation

Based on the mass fraction needed, calculate the mass of hydrochloric acid and distilled water required to prepare hydrochloric acid solution according to [Formulae \(1\)](#) and [\(2\)](#). During system configuration, hydrochloric acid shall be added to distilled water with continuous stir until the solution is uniform. After constant mass, it shall be stored in a glass vial waiting for use.

Calculate the mass of hydrochloric acid using [Formula \(1\)](#):

$$m_0 = \frac{mW}{W_0} \quad (1)$$

where

- m_0 is the mass of hydrochloric acid, in g;
- m is the mass of hydrochloric acid solution, in g;
- W is the mass fraction of hydrogen chloride in hydrochloric acid solution, in %;
- W_0 is the mass fraction of hydrogen chloride in hydrochloric acid, in %.

Calculate the mass of distilled water using [Formula \(2\)](#):

$$m_w = m - m_0 \quad (2)$$

where m_w is the mass of distilled water used in hydrochloric acid solution preparation, in g.

The following is an example of preparing 500 g of 20 % hydrochloric acid solution using 37 % hydrochloric acid.

Mass of hydrochloric acid, $m_0 = 270,27$ g ($m_0 = \frac{500 \times 20\%}{37\%}$). Mass of distilled water, $m_w = 229,73$ g ($m_w = 500 - 270,27$). During the preparation, hydrochloric acid shall be added to distilled water with continuous stir until uniform.

b) Hydrochloric acid acidizing fluid system preparation

When preparing hydrochloric acid acidizing fluid system, the mass of hydrochloric acid is calculated according to [Formula \(1\)](#), and other additives shall be added accordingly based on mass fraction. Calculate the mass of additives using [Formula \(3\)](#), which shall be subtracted from the distilled water:

$$m_n = mW_n \quad (3)$$

where

- m_n is the mass of additives, in g;
- W_n is the mass fraction of additives, in %.

Calculate the mass of distilled water using [Formula \(4\)](#):

$$m'_w = m_w - m_n \quad (4)$$

where m'_w is the mass of distilled water used in hydrochloric acid acidizing fluid system preparation, in g.

The following is an example.

Conditions and requirements: 500 g hydrochloric acid acidizing fluid system shall be prepared with 37 % hydrochloric acid.