**Geometrical product specifications
(GPS) — ISO code system for tolerances
on linear sizes —**

**Part 1:
Basis of tolerances, deviations and fits**

*Spécification géométrique des produits (GPS) — Système de
codification ISO pour les tolérances sur les tailles linéaires —*

Partie 1: Base des tolérances, écarts et ajustements

Sample Document

get full document from standards.iteh.ai



PDF disclaimer

This PDF file may contain embedded typefaces. In accordance with Adobe's licensing policy, this file may be printed or viewed but shall not be edited unless the typefaces which are embedded are licensed to and installed on the computer performing the editing. In downloading this file, parties accept therein the responsibility of not infringing Adobe's licensing policy. The ISO Central Secretariat accepts no liability in this area.

Adobe is a trademark of Adobe Systems Incorporated.

Details of the software products used to create this PDF file can be found in the General Info relative to the file; the PDF-creation parameters were optimized for printing. Every care has been taken to ensure that the file is suitable for use by ISO member bodies. In the unlikely event that a problem relating to it is found, please inform the Central Secretariat at the address given below.

Sample Document

get full document from standards.iteh.ai



COPYRIGHT PROTECTED DOCUMENT

© ISO 2010

All rights reserved. Unless otherwise specified, no part of this publication may be reproduced or utilized in any form or by any means, electronic or mechanical, including photocopying and microfilm, without permission in writing from either ISO at the address below or ISO's member body in the country of the requester.

ISO copyright office
Case postale 56 • CH-1211 Geneva 20
Tel. + 41 22 749 01 11
Fax + 41 22 749 09 47
E-mail copyright@iso.org
Web www.iso.org

Published in Switzerland

Contents

Page

| | |
|--|-----------|
| Foreword | iv |
| Introduction..... | v |
| 1 Scope | 1 |
| 2 Normative references | 1 |
| 3 Terms and definitions | 1 |
| 3.1 Basic terminology | 2 |
| 3.2 Terminology related to tolerances and deviations | 2 |
| 3.3 Terminology related to fits | 5 |
| 3.4 Terminology related to the ISO fit system | 9 |
| 4 ISO code system for tolerances on linear sizes | 11 |
| 4.1 Basic concepts and designations | 11 |
| 4.2 Designation of the tolerance class (writing rules) | 13 |
| 4.3 Determination of the limit deviations (reading rules) | 14 |
| 4.4 Selection of tolerance classes | 26 |
| 5 ISO fit system..... | 26 |
| 5.1 General | 26 |
| 5.2 Generics of fits | 27 |
| 5.3 Determination of a fit..... | 27 |
| Annex A (informative) Further information about the ISO system of limits and fits and former practice | 29 |
| Annex B (informative) Examples of the use of ISO 286-1 to determine fits and tolerance classes | 31 |
| Annex C (informative) Relationship to the GPS matrix model | 36 |
| Bibliography..... | 38 |

Foreword

ISO (the International Organization for Standardization) is a worldwide federation of national standards bodies (ISO member bodies). The work of preparing International Standards is normally carried out through ISO technical committees. Each member body interested in a subject for which a technical committee has been established has the right to be represented on that committee. International organizations, governmental and non-governmental, in liaison with ISO, also take part in the work. ISO collaborates closely with the International Electrotechnical Commission (IEC) on all matters of electrotechnical standardization.

International Standards are drafted in accordance with the rules given in the ISO/IEC Directives, Part 2.

The main task of technical committees is to prepare International Standards. Draft International Standards adopted by the technical committees are circulated to the member bodies for voting. Publication as an International Standard requires approval by at least 75 % of the member bodies casting a vote.

Attention is drawn to the possibility that some of the elements of this document may be the subject of patent rights. ISO shall not be held responsible for identifying any or all such patent rights.

ISO 286-1 was prepared by Technical Committee ISO/TC 213, *Dimensional and geometrical product specifications and verification*.

This second edition of ISO 286-1 cancels and replaces ISO 286-1:1988 and ISO 1829:1975, which have been technically revised.

ISO 286 consists of the following parts, under the general title *Geometrical product specifications (GPS) — ISO code system for tolerances on linear sizes*:

- *Part 1: Basis of tolerances, deviations and fits*
- *Part 2: Tables of standard tolerance grades and limit deviations for holes and shafts*

Introduction

This International Standard is a geometrical product specification (GPS) standard and is to be regarded as a general GPS standard (see ISO/TR 14638). It influences chain links 1 and 2 of the chain of standards on size in the general GPS matrix.

For more detailed information on the relation of this part of ISO 286 to the GPS matrix model, see Annex C.

The need for limits and fits for machined workpieces was brought about mainly by the requirement for interchange ability between mass produced parts and the inherent inaccuracy of manufacturing methods, coupled with the fact that “exactness” of size was found to be unnecessary for the most workpiece features. In order that fit function could be satisfied, it was found sufficient to manufacture a given workpiece so that its size lay within two permissible limits, i.e. a tolerance, this being the variation in size acceptable in manufacture while ensuring the functional fit requirements of the product.

Similarly, where a specific fit condition is required between mating features of two different workpieces, it is necessary to ascribe an allowance, either positive or negative, to the nominal size to achieve the required clearance or interference. This part of ISO 286 gives the internationally accepted code system for tolerances on linear sizes. It provides a system of tolerances and deviations suitable for two features of size types: “cylinder” and “two parallel opposite surfaces”. The main intention of this code system is the fulfilment of the function fit.

The terms “hole”, “shaft” and “diameter” are used to designate features of size type cylinder (e.g. for the tolerancing of diameter of a hole or shaft). For simplicity, they are also used for two parallel opposite surfaces (e.g. for the tolerancing of thickness of a key or width of a slot).

The pre-condition for the application of the ISO code system for tolerances on linear sizes for the features forming a fit is that the nominal sizes of the hole and the shaft are identical.

The previous edition of ISO 286-1 (published in 1988) had the envelope criterion as the default association criterion for the size of a feature of size; however, ISO 14405-1 changes this default association criterion to the two-point size criterion. This means that form is no longer controlled by the default specification of size.

In many cases, the diameter tolerances according to this part of ISO 286 are not sufficient for an effective control of the intended function of the fit. The envelope criterion according to ISO 14405-1 may be required. In addition, the use of geometrical form tolerances and surface texture requirements may improve the control of the intended function.

Sample Document

get full document from standards.iteh.ai

Geometrical product specifications (GPS) — ISO code system for tolerances on linear sizes —

Part 1: Basis of tolerances, deviations and fits

1 Scope

This part of ISO 286 establishes the ISO code system for tolerances to be used for linear sizes of features of the following types:

- a) cylinder;
- b) two parallel opposite surfaces.

It defines the basic concepts and the related terminology for this code system. It provides a standardized selection of tolerance classes for general purposes from amongst the numerous possibilities.

Additionally, it defines the basic terminology for fits between two features of size without constraints of orientation and location and explains the principles of “basic hole” and “basic shaft”.

get full document from standards.iteh.ai

2 Normative references

The following referenced documents are indispensable for the application of this document. For dated references, only the edition cited applies. For undated references, the latest edition of the referenced document (including any amendments) applies.

ISO 286-2¹⁾, *Geometrical product specifications (GPS) — ISO code system for tolerances on linear sizes — Part 2: Tables of standard tolerance grades and limit deviations for holes and shafts*

ISO 14405-1, *Geometrical product specifications (GPS) — Dimensional tolerancing — Part 1: Linear sizes*

ISO 14660-1:1999, *Geometrical Product Specifications (GPS) — Geometrical features — Part 1: General terms and definitions*

ISO 14660-2:1999, *Geometrical Product Specifications (GPS) — Geometrical features — Part 2: Extracted median line of a cylinder and a cone, extracted median surface, local size of an extracted feature*

3 Terms and definitions

For the purposes of this document, the terms and definitions given in ISO 14405-1 and ISO 14660-1 and the following apply. It should be noted, however, that some of the terms are defined in a more restricted sense than in common usage.

1) To be published. (Revision of ISO 286-2:1988)

3.1 Basic terminology

3.1.1

feature of size

geometrical shape defined by a linear or angular dimension which is a size

[ISO 14660-1:1999, definition 2.2]

NOTE 1 The feature of size can be a cylinder, a sphere, two parallel opposite surfaces.

NOTE 2 In former editions of international standards, such as ISO 286-1 and ISO/R 1938, the meanings of the terms “plain workpiece” and “single features” are close to that of “feature of size”.

NOTE 3 For the purpose of ISO 286, only features of size type cylinder as well as type-two parallel opposite surfaces, defined by a linear dimension, apply.

3.1.2

nominal integral feature

theoretically exact integral feature as defined by a technical drawing or by other means

[ISO 14660-1:1999, definition 2.3]

3.1.3

hole

internal feature of size of a workpiece, including internal features of size which are not cylindrical

NOTE See also Introduction.

3.1.4

basic hole

hole chosen as a basis for a hole-basis fit system

NOTE 1 See also 3.4.1.1.

NOTE 2 For the purpose of the ISO code system, a basic hole is a hole for which the lower limit deviation is zero.

3.1.5

shaft

external feature of size of a workpiece, including external features of size which are not cylindrical

NOTE See also Introduction.

3.1.6

basic shaft

shaft chosen as a basis for a shaft-basis fit system

NOTE 1 See also 3.4.1.2.

NOTE 2 For the purposes of the ISO code system, a basic shaft is a shaft for which the upper limit deviation is zero.

3.2 Terminology related to tolerances and deviations

3.2.1

nominal size

size of a feature of perfect form as defined by the drawing specification

See Figure 1.

NOTE 1 Nominal size is used for the location of the limits of size by the application of the upper and lower limit deviations.

NOTE 2 In former times, this was referred to as “basic size”.

3.2.2**actual size**

size of the associated integral feature

NOTE 1 "Associated integral feature" is defined in ISO 14660-1:1999, 2.6.

NOTE 2 The actual size is obtained by measurement.

3.2.3**limits of size**

extreme permissible sizes of a feature of size

NOTE To fulfil the requirement, the actual size shall lie between the upper and lower limits of size; the limits of size are also included.

3.2.3.1**upper limit of size****ULS**

largest permissible size of a feature of size

See Figure 1.

3.2.3.2**lower limit of size****LLS**

smallest permissible size of a feature of size

See Figure 1.

3.2.4**deviation**

value minus its reference value

NOTE For size deviations, the reference value is the nominal size and the value is the actual size.

3.2.5**limit deviation**

upper limit deviation or lower limit deviation from nominal size

3.2.5.1**upper limit deviation**

ES (to be used for internal features of size)

es (to be used for external features of size)

upper limit of size minus nominal size

See Figure 1.

NOTE Upper limit deviation is a signed value and may be negative, zero or positive.

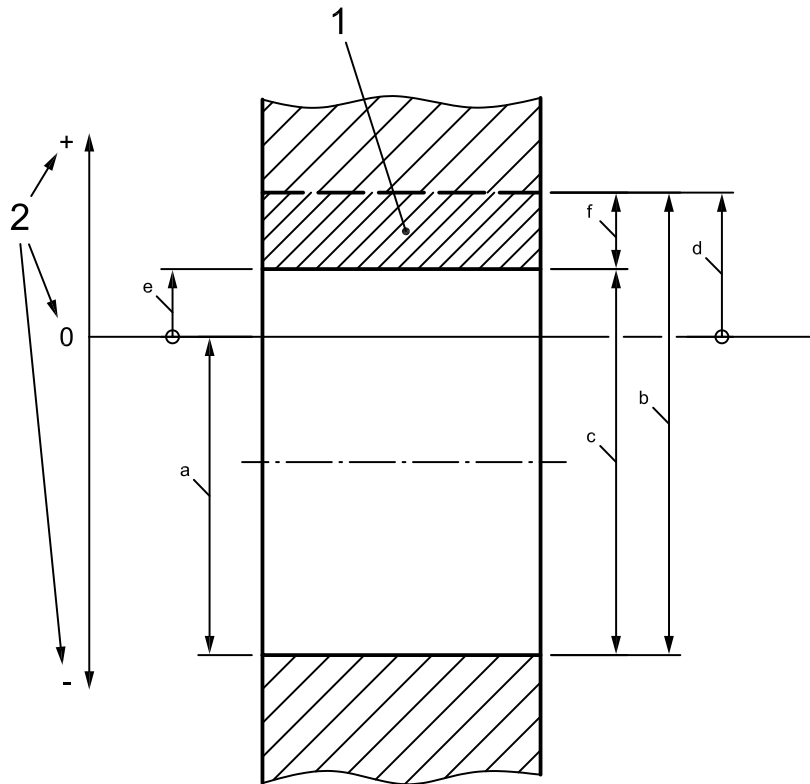

Key

- 1 tolerance interval
- 2 sign convention for deviations
- a Nominal size.
- b Upper limit of size.
- c Lower limit of size.
- d Upper limit deviation.
- e Lower limit deviation (in this case also fundamental deviation).
- f Tolerance.

NOTE The horizontal continuous line, which limits the tolerance interval, represents the fundamental deviations for a hole. The dashed line, which limits the tolerance interval, represents the other limit deviation for a hole.

Figure 1 — Illustration of definitions (a hole is used in the example)

3.2.5.2

lower limit deviation

EI (to be used for internal features of size)

ei (to be used for external features of size)

lower limit of size minus nominal size

See Figure 1.

NOTE Lower limit deviation is a signed value and may be negative, zero or positive.

3.2.6

fundamental deviation

limit deviation that defines the placement of the tolerance interval in relation to the nominal size

NOTE 1 The fundamental deviation is that limit deviation, which defines that limit of size which is the nearest to the nominal size (see Figure 1 and 4.1.2.5).

NOTE 2 The fundamental deviation is identified by a letter (e.g. B, d).

3.2.7 **Δ value**

variable value added to a fixed value to obtain the fundamental deviation of an internal feature of size

See Table 3.

3.2.8**tolerance**

difference between the upper limit of size and the lower limit of size

NOTE 1 The tolerance is an absolute quantity without sign.

NOTE 2 The tolerance is also the difference between the upper limit deviation and the lower limit deviation.

3.2.8.1**tolerance limits**

specified values of the characteristic giving upper and/or lower bounds of the permissible value

3.2.8.2**standard tolerance****IT**

any tolerance belonging to the ISO code system for tolerances on linear sizes

NOTE The letters in the abbreviated term "IT" stand for "International Tolerance".

3.2.8.3**standard tolerance grade**

group of tolerances for linear sizes characterized by a common identifier

NOTE 1 In the ISO code system for tolerances on linear sizes, the standard tolerance grade identifier consists of IT followed by a number (e.g. IT7); see 4.1.2.3.

NOTE 2 A specific tolerance grade is considered as corresponding to the same level of accuracy for all nominal sizes.

3.2.8.4**tolerance interval**

variable values of the size between and including the tolerance limits

NOTE 1 The former term "tolerance zone", which was used in connection with linear dimensioning (according to ISO 286-1:1988), has been changed to "tolerance interval" since an interval refers to a range on a scale whereas a tolerance zone in GPS refers to a space or an area, e.g. tolerancing according to ISO 1101.

NOTE 2 For the purpose of ISO 286, the interval is contained between the upper and the lower limits of size. It is defined by the magnitude of the tolerance and its placement relative to the nominal size (see Figure 1).

NOTE 3 The tolerance interval does not necessarily include the nominal size (see Figure 1). Tolerance limits may be two-sided (values on both sides of the nominal size) or one-sided (both values on one side of the nominal size). The case where the one tolerance limit is on one side, the other limit value being zero, is a special case of a one-sided indication.

3.2.8.5**tolerance class**

combination of a fundamental deviation and a standard tolerance grade

NOTE In the ISO code system for tolerances on linear sizes, the tolerance class consists of the fundamental deviation identifier followed by the tolerance grade number (e.g. D13, h9, etc.), see 4.2.1.

3.3 Terminology related to fits

The concepts in this clause relate only to nominal features of size (perfect form). For the model definition of a nominal feature of size, see ISO 17450-1:—, 3.18.

For the determination of a fit, see 5.3.

3.3.1

clearance

difference between the size of the hole and the size of the shaft when the diameter of the shaft is smaller than the diameter of the hole

NOTE In the calculation of clearance, the obtained values are positive (see B.2).

3.3.1.1

minimum clearance

(in a clearance fit) difference between the lower limit of size of the hole and the upper limit of size of the shaft

See Figure 2.

3.3.1.2

maximum clearance

(in a clearance or transition fit) difference between the upper limit of size of the hole and the lower limit of size of the shaft

See Figures 2 and 4.

3.3.2

interference

difference before mating between the size of the hole and the size of the shaft when the diameter of the shaft is larger than the diameter of the hole

NOTE In the calculation of an interference, the obtained values are negative (see B.2).

3.3.2.1

minimum interference

(in an interference fit) difference between the upper limit of size of the hole and the lower limit of size of the shaft

See Figure 3.

3.3.2.2

maximum interference

(in an interference or transition fit) difference between the lower limit of size of the hole and the upper limit of size of the shaft

See Figures 3 and 4.

3.3.3

fit

relationship between an external feature of size and an internal feature of size (the hole and shaft of the same type) which are to be assembled

3.3.3.1

clearance fit

fit that always provides a clearance between the hole and shaft when assembled, i.e. the lower limit of size of the hole is either larger than or, in the extreme case, equal to the upper limit of size of the shaft

See Figure 2.

3.3.3.2

interference fit

fit that always provides an interference between the hole and the shaft when assembled, i.e. the upper limit of size of the hole is either smaller than or, in the extreme case, equal to the lower limit of size of the shaft

See Figure 3.