

---

---

**Indexable hardmetal (carbide) inserts  
with wiper edges, without fixing  
hole — Dimensions**

*Plaquettes amovibles en métaux-durs (carbures métalliques) avec  
arêtes de planage, sans trou de fixation — Dimensions*

Sample Document

get full document from [standards.iteh.ai](https://standards.iteh.ai)



Reference number  
ISO 3365:2016(E)

© ISO 2016

# Sample Document

get full document from [standards.iteh.ai](https://standards.iteh.ai)



## **COPYRIGHT PROTECTED DOCUMENT**

© ISO 2016, Published in Switzerland

All rights reserved. Unless otherwise specified, no part of this publication may be reproduced or utilized otherwise in any form or by any means, electronic or mechanical, including photocopying, or posting on the internet or an intranet, without prior written permission. Permission can be requested from either ISO at the address below or ISO's member body in the country of the requester.

ISO copyright office  
Ch. de Blandonnet 8 • CP 401  
CH-1214 Vernier, Geneva, Switzerland  
Tel. +41 22 749 01 11  
Fax +41 22 749 09 47  
[copyright@iso.org](mailto:copyright@iso.org)  
[www.iso.org](http://www.iso.org)

# Contents

	Page
Foreword .....	iv
<b>1 Scope</b> .....	<b>1</b>
<b>2 Normative references</b> .....	<b>1</b>
<b>3 Types of inserts</b> .....	<b>1</b>
<b>4 Interchangeability</b> .....	<b>2</b>
4.1 Tolerances .....	2
4.2 Dimensions <i>m</i> .....	2
<b>5 Designation and marking</b> .....	<b>2</b>
5.1 Designation .....	2
5.2 Marking .....	2
<b>6 Measurement</b> .....	<b>2</b>
<b>7 Recommended dimensions</b> .....	<b>3</b>
7.1 Triangular inserts .....	3
7.1.1 Symmetrical triangular inserts with 90° cutting edge angle, 11° normal clearance, and 11° wiper edge normal clearance .....	3
7.1.2 Asymmetrical triangular inserts with chamfered corners, 90° cutting edge angle, 11° normal clearance, and 15° wiper edge normal clearance .....	4
7.1.3 Asymmetrical triangular inserts with chamfered corners, 90° cutting edge angle, 20° normal clearance, and 20° wiper edge normal clearance .....	5
7.2 Square inserts .....	6
7.2.1 Symmetrical square inserts with chamfered corner, 75° cutting edge angle, 0° normal clearance, and 0° wiper edge normal clearance .....	6
7.2.2 Asymmetrical square inserts with chamfered corner, 75° cutting edge angle, 11° normal clearance, and 15° wiper edge normal clearance .....	7
7.2.3 Symmetrical square inserts with 45° cutting edge angle, 0° normal clearance, and 0° wiper edge normal clearance .....	8
7.2.4 Asymmetrical square inserts without chamfered corner, 75° cutting edge angle, 20° normal clearance, and 20° wiper edge normal clearance .....	9
<b>Annex A (normative) Tolerances for <i>d</i>, <i>m</i>, and <i>s</i></b> .....	<b>10</b>
<b>Annex B (normative) Method of measurement of “<i>m</i>” dimension</b> .....	<b>11</b>
<b>Annex C (normative) Range of sizes for inserts with wiper edges, without fixation hole</b> .....	<b>12</b>
<b>Annex D (informative) Relationship between designations in this International Standard and ISO 13399</b> .....	<b>14</b>
<b>Bibliography</b> .....	<b>15</b>

## Foreword

ISO (the International Organization for Standardization) is a worldwide federation of national standards bodies (ISO member bodies). The work of preparing International Standards is normally carried out through ISO technical committees. Each member body interested in a subject for which a technical committee has been established has the right to be represented on that committee. International organizations, governmental and non-governmental, in liaison with ISO, also take part in the work. ISO collaborates closely with the International Electrotechnical Commission (IEC) on all matters of electrotechnical standardization.

The procedures used to develop this document and those intended for its further maintenance are described in the ISO/IEC Directives, Part 1. In particular the different approval criteria needed for the different types of ISO documents should be noted. This document was drafted in accordance with the editorial rules of the ISO/IEC Directives, Part 2 (see [www.iso.org/directives](http://www.iso.org/directives)).

Attention is drawn to the possibility that some of the elements of this document may be the subject of patent rights. ISO shall not be held responsible for identifying any or all such patent rights. Details of any patent rights identified during the development of the document will be in the Introduction and/or on the ISO list of patent declarations received (see [www.iso.org/patents](http://www.iso.org/patents)).

Any trade name used in this document is information given for the convenience of users and does not constitute an endorsement.

For an explanation on the meaning of ISO specific terms and expressions related to conformity assessment, as well as information about ISO's adherence to the WTO principles in the Technical Barriers to Trade (TBT) see the following URL: [Foreword - Supplementary information](#)

The committee responsible for this document is ISO/TC 29, *Small tools*, Subcommittee SC 9, *Tools with defined cutting edges, cutting items*.

This third edition cancels and replaces the second edition (ISO 3365:1985), of which it constitutes a minor revision.

# Indexable hardmetal (carbide) inserts with wiper edges, without fixing hole — Dimensions

## 1 Scope

This International Standard specifies the dimensions of indexable hardmetal (carbide) inserts with wiper edges, without fixing hole. These inserts are primarily intended to be mounted on milling cutters by top or wedge clamping.

## 2 Normative references

The following documents, in whole or in part, are normatively referenced in this document and are indispensable for its application. For dated references, only the edition cited applies. For undated references, the latest edition of the referenced document (including any amendments) applies.

ISO 513, *Classification and application of hard cutting materials for metal removal with defined cutting edges — Designation of the main groups and groups of application*

ISO 1832, *Indexable inserts for cutting tools — Designation*

## 3 Types of inserts

The types of indexable hardmetal (carbide) inserts specified in this International Standard are the following:

— TP ... PPN

symmetrical triangular inserts with 11° normal clearance, 90° cutting edge angle, and 11° wiper edge normal clearance;

— TP ... PDR; TP ... PDL

asymmetrical triangular inserts with chamfered corners, 11° normal clearance, 90° cutting edge angle, and 15° wiper edge normal clearance;

— TE ... PER; TE ... PEL

asymmetrical triangular inserts with chamfered corners, 20° normal clearance, 90° cutting edge angle, and 20° wiper edge normal clearance;

— SN ... ENN

symmetrical square insert with chamfered corners, 0° normal clearance, 75° cutting edge angle, and 0° wiper edge normal clearance;

— SP ... EDR; SP ... EDL

asymmetrical square insert with chamfered corners, 11° normal clearance, 75° cutting edge angle, and 15° wiper edge normal clearance;

— SN ... ANN

symmetrical square insert with 0° normal clearance, 45° cutting edge angle, and 0° wiper edge normal clearance;

— SE... EER; SE... EEL

asymmetrical square insert with 20° normal clearance, 75° cutting edge angle, and 20° wiper edge normal clearance.

Inserts with wiper edges, without fixing hole, are standardized only without chip breakers.

## 4 Interchangeability

### 4.1 Tolerances

Indexable hardmetal (carbide) inserts specified in this International Standard are provided in the following tolerance classes in accordance with ISO 1832:

- a) inserts with 0° and 11° normal clearance (TP, SN, and SP)  
tolerance classes A, C, and K, where class C is used mainly for coated inserts;
- b) inserts with 20° normal clearance (TE and SE)  
tolerance class C.

The values of the tolerances in accordance with ISO 1832 are given in [Annex A](#).

Other tolerances are included in the diagrams and tables with the insert dimensions in [Clause 7](#).

### 4.2 Dimensions *m*

Dimension *m* specified in the tables refers to a theoretically perfect insert. In practice, as the points on which the inserts are located in both manufacturing and measuring may be different, the nominal value of dimension *m* may vary from one manufacturer to another within a range of ± 0,05 mm. Nevertheless, for inserts of the same manufacturer, dimension *m* shall comply with the tolerances in accordance with ISO 1832 (see [Annex A](#)).

## 5 Designation and marking

### 5.1 Designation

The designation of the indexable hardmetal (carbide) inserts complying with this International Standard shall conform to ISO 1832.

In addition to this designation, one or both of the following may be indicated:

- the symbol of the group of application, in accordance with ISO 513;
- the commercial designation of the hardmetal (carbide) grade.

### 5.2 Marking

The following symbol, at least, shall be marked on the insert itself (except when this would be difficult on the smaller inserts):

- symbol of the group of application or commercial designation of the hardmetal (carbide) grade (or both, if possible, on large inserts).

## 6 Measurement

[Annex B](#) indicates the methods of measuring the dimension *m* of the indexable inserts covered by this International Standard.

## 7 Recommended dimensions

The choice of the more common dimensions is restricted to the specifications given in [Tables 1](#) to [12](#). It is strongly recommended that these standard inserts be used wherever possible.

### 7.1 Triangular inserts

#### 7.1.1 Symmetrical triangular inserts with 90° cutting edge angle, 11° normal clearance, and 11° wiper edge normal clearance

TPAN ... PPN

TPCN ... PPN

TPKN ... PPN

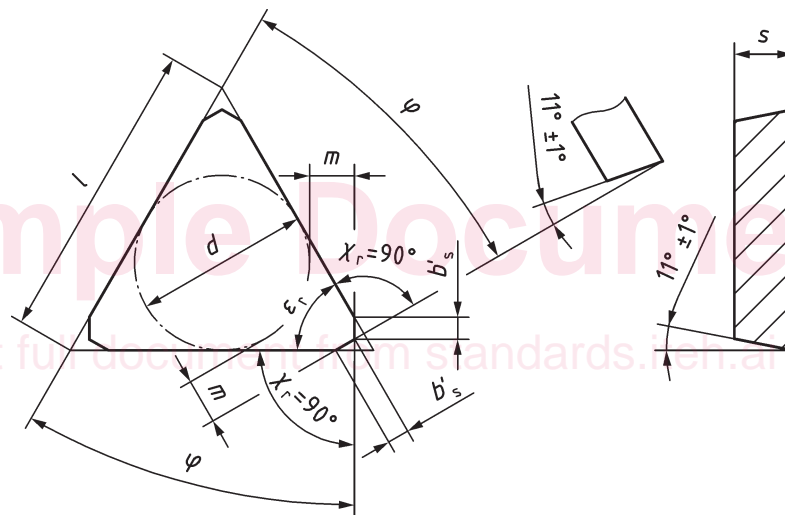

Figure 1

Table 1

Values in millimetres

Insert			$l$	$d^a$	$s^a$	$m^a$	$b'_s$	$\epsilon_r$	$\varphi$
			$\approx$				$\approx$		
TPAN1103 PPN	TPCN1103 PPN	TPKN1103 PPN	11,0	6,35	3,175	1,72	0,7	60°	30°
TPAN1603 PPN	TPCN1603 PPN	TPKN1603 PPN	16,5	9,525		2,45	1,2		
TPAN2204 PPN	TPCN2204 PPN	TPKN2204 PPN	22,0	12,70	4,76	3,55	1,3		

<sup>a</sup> Tolerances in accordance with ISO 1832. See [Annex A](#).