

Second edition
2014-12-15

Corrected version
2015-09-01

Wheelchairs —

Part 8: Requirements and test methods for static, impact and fatigue strengths

Fauteuils roulants —

*Partie 8: Prescriptions et méthodes d'essai pour la résistance statique,
la résistance aux chocs et la résistance à la fatigue*

Sample Document

get full document from standards.iteh.ai



Reference number
ISO 7176-8:2014(E)

© ISO 2014

Sample Document

get full document from standards.iteh.ai



COPYRIGHT PROTECTED DOCUMENT

© ISO 2014, Published in Switzerland

All rights reserved. Unless otherwise specified, no part of this publication may be reproduced or utilized otherwise in any form or by any means, electronic or mechanical, including photocopying, or posting on the internet or an intranet, without prior written permission. Permission can be requested from either ISO at the address below or ISO's member body in the country of the requester.

ISO copyright office
Ch. de Blandonnet 8 • CP 401
CH-1214 Vernier, Geneva, Switzerland
Tel. +41 22 749 01 11
Fax +41 22 749 09 47
copyright@iso.org
www.iso.org

Contents

	Page
Foreword	v
Introduction	vii
1 Scope	1
2 Normative references	1
3 Terms and definitions	1
4 Requirements	2
4.1 Strength requirements	2
4.2 Disclosure requirements	3
5 Test apparatus	3
6 Preparation of the test wheelchair	13
6.1 Setup and adjustment of the wheelchair	13
6.2 Test dummies	14
6.3 Preparation of wheelchair	14
6.4 Records	14
6.5 Safety during testing	14
7 Sequence of tests	14
8 Test methods for static strength	15
8.1 Principle	15
8.2 Wheelchair preparation	15
8.3 Selection of loading pad	15
8.4 Arm supports: Resistance to downward forces	15
8.5 Foot supports: Resistance to downward forces	16
8.6 Tipping levers	19
8.7 Handgrips	21
8.8 Arm supports: Resistance to upward forces	22
8.9 Foot supports: Resistance to upward forces	24
8.10 Push handles: Resistance to upward load	27
8.11 Scooter steering handles: Resistance to forward forces	29
8.12 Scooter steering handles: Resistance to rearward forces	30
8.13 Scooter steering handles: Resistance to downward forces	31
8.14 Scooter steering handles: Resistance to upward forces	32
9 Test methods for impact strength	33
9.1 Principle	33
9.2 Wheelchair preparation	33
9.3 Back support: Resistance to impact	33
9.4 Handrim: Resistance to impact	35
9.5 Castors: Resistance to impact	36
9.6 Foot supports: Resistance to impact	38
9.6.1 General	38
9.6.2 Preparation	38
9.6.3 Lateral impact	38
9.6.4 Longitudinal impact	40
9.7 Impacts on anti-tip devices	40
9.7.1 Upward impacts on anti-tip devices	40
9.7.2 Forward or rearward impacts on anti-tip devices	41
9.7.3 Lateral impacts on anti-tip devices	41
10 Fatigue tests	43
10.1 Principle	43
10.2 Preparation of test wheelchair for fatigue tests	43
10.3 Multi-drum test	44

10.3.1	Test machine settings	44
10.3.2	Manual wheelchair tests	44
10.3.3	Preliminary power measurement for electrically powered wheelchairs	44
10.3.4	Electrical wheelchair tests	45
10.4	Drop test	46
10.5	Fatigue test of manually operated parking brakes	48
11	Evaluation of test results	49
11.1	Evaluation and records of individual tests	49
11.2	Evaluation at end of testing	49
12	Test report	49
Annex A	(informative) Principles applied to derive static test loads	51
Annex B	(informative) Design considerations	61
Annex C	(informative) Derivation of pendulum swing angle for castor and foot support impact tests	62
Annex D	(informative) Calculation of pendulum centre of percussion	65
Bibliography	67

Sample Document

get full document from standards.iteh.ai

Foreword

ISO (the International Organization for Standardization) is a worldwide federation of national standards bodies (ISO member bodies). The work of preparing International Standards is normally carried out through ISO technical committees. Each member body interested in a subject for which a technical committee has been established has the right to be represented on that committee. International organizations, governmental and non-governmental, in liaison with ISO, also take part in the work. ISO collaborates closely with the International Electrotechnical Commission (IEC) on all matters of electrotechnical standardization.

The procedures used to develop this document and those intended for its further maintenance are described in the ISO/IEC Directives, Part 1. In particular the different approval criteria needed for the different types of ISO documents should be noted. This document was drafted in accordance with the editorial rules of the ISO/IEC Directives, Part 2 (see www.iso.org/directives).

Attention is drawn to the possibility that some of the elements of this document may be the subject of patent rights. ISO shall not be held responsible for identifying any or all such patent rights. Details of any patent rights identified during the development of the document will be in the Introduction and/or on the ISO list of patent declarations received (see www.iso.org/patents).

Any trade name used in this document is information given for the convenience of users and does not constitute an endorsement.

For an explanation on the meaning of ISO specific terms and expressions related to conformity assessment, as well as information about ISO's adherence to the WTO principles in the Technical Barriers to Trade (TBT), see the following URL: [Foreword — Supplementary information](#).

The committee responsible for this document is ISO/TC 173, *Assistive products for persons with a disability*, Subcommittee SC 1, *Wheelchairs*.

This second edition cancels and replaces the first edition (ISO 7176-8:1998), which has been technically revised.

ISO 7176 consists of the following parts, under the general title *Wheelchairs*:

- *Part 1: Determination of static stability*
- *Part 2: Determination of dynamic stability of electric wheelchairs*
- *Part 3: Determination of the effectiveness of brakes*
- *Part 4: Energy consumption of electric wheelchairs and scooters for determination of theoretical distance range*
- *Part 5: Determination of dimensions, mass and manoeuvring space*
- *Part 6: Determination of maximum speed, acceleration and deceleration of electric wheelchairs*
- *Part 7: Measurement of seating and wheel dimensions*
- *Part 8: Requirements and test methods for static, impact and fatigue strengths*
- *Part 9: Climatic tests for electric wheelchairs*
- *Part 10: Determination of obstacle-climbing ability of electrically powered wheelchairs*
- *Part 11: Test dummies*
- *Part 13: Determination of coefficient of friction of test surfaces*
- *Part 14: Power and control systems for electrically powered wheelchairs and scooters – Requirements and test methods*

ISO 7176-8:2014(E)

- *Part 15: Requirements for information disclosure, documentation and labelling*
- *Part 16: Resistance to ignition of postural support devices*
- *Part 19: Wheeled mobility devices for use as seats in motor vehicles*
- *Part 21: Requirements and test methods for electromagnetic compatibility of electrically powered wheelchairs and scooters, and battery chargers*
- *Part 22: Set-up procedures*
- *Part 25: Batteries and chargers for powered wheelchairs*
- *Part 26: Vocabulary*
- *Part 28: Requirements and test methods for stair-climbing devices*

A technical report (ISO/TR 13570-1) is also available giving a simplified explanation of these parts of ISO 7176.

This corrected version of ISO 7176-8:2014 incorporates the following correction:

- In [9.7.1](#), the last sentence of the third paragraph has been amended.

Sample Document

get full document from standards.iteh.ai

Introduction

This part of ISO 7176 has been an important part of the strength testing of wheelchairs since its publication in 1998. It contains test methods and sets minimum requirements for static, impact, and fatigue strength of both the overall wheelchair and individually stressed components.

Several parts of this International Standard have been reviewed. In particular:

- the fatigue testing elements, including the speed and size of slat of the two-drum test machine, and the number of test cycles for both two drum and drop tests have been reviewed through empirical testing and confirmed;
- the failure criteria have been clarified, and permissible adjustments and repairs more clearly defined to minimize variation between laboratories;
- a more precisely defined setup procedure for the reference configuration of adjustable wheelchairs as given in ISO 7176-22;
- static, impact, and repeated load test procedures for Postural Support Devices (PSDs) have been revised and are contained in ISO 16840-3.

It is anticipated that all parts of this International Standard will continue to be developed and future revisions may include the results of ongoing work in the following areas:

- consideration of whether the fatigue test requirements should be revised for wheelchairs intended for use in less resourced settings;
- review of the test methods and apparatus to facilitate testing in less resourced settings;
- further development of the test dummies to improve the way in which they load the backs of test wheelchairs and, in particular, to improve their suitability for use with wheelchairs with low back supports.

Sample Document

get full document from standards.iteh.ai

Wheelchairs —

Part 8:

Requirements and test methods for static, impact and fatigue strengths

1 Scope

This part of ISO 7176 specifies requirements for static, impact, and fatigue strength of wheelchairs including scooters. It specifies the test methods for determining whether the requirements have been met. It also specifies requirements for disclosure of the test results.

The test methods can also be used to verify the manufacturers' claims that a product exceeds the minimum requirements of this part of ISO 7176.

This International Standard applies to occupant- and attendant-propelled manual wheelchairs and electrically powered wheelchairs intended to provide indoor and outdoor mobility for people with disabilities.

NOTE 1 For the purposes of this part of ISO 7176, "wheelchair(s)" is used as an abbreviation for manual wheelchair(s) or electrically powered wheelchair(s), including scooter(s), to which the requirements and test methods are applied.

NOTE 2 Clauses of this part of ISO 7176 will be used as a basis for developing requirements and test methods for wheelchairs not covered by this part of ISO 7176.

2 Normative references

The following documents, in whole or in part, are normatively referenced in this document and are indispensable for its application. For dated references, only the edition cited applies. For undated references, the latest edition of the referenced document (including any amendments) applies.

ISO 7176-6, *Wheelchairs — Part 6: Determination of maximum speed, acceleration and deceleration of electric wheelchairs*

ISO 7176-7, *Wheelchairs — Part 7: Measurement of seating and wheel dimensions*

ISO 7176-11, *Wheelchairs — Part 11: Test dummies*

ISO 7176-15, *Wheelchairs — Part 15: Requirements for information disclosure, documentation and labelling*

ISO 7176-22, *Wheelchairs — Part 22: Set-up procedures*

ISO 7176-26, *Wheelchairs — Part 26: Vocabulary*

3 Terms and definitions

For the purposes of this document, the terms and definitions given in ISO 7176-7, ISO 7176-11, ISO 7176-26, and the following apply.

3.1

fracture

unintentional separation (of a component) into two or more pieces

**3.2
operator adjustable**

intended to be adjusted, moved, or set up by the operator without the help of tools or with the help of tools if those tools are supplied with the wheelchair

**3.3
visible crack**

break, without complete separation into parts, visible to the naked eye and which has occurred during a test

4 Requirements

4.1 Strength requirements

When tested in accordance with [Clauses 8, 9](#), and [10](#), a single wheelchair shall meet all the following requirements at the conclusion of the tests.

- a) No component shall show evidence of visible cracks, be fractured, or have become detached, with the following exceptions.
 - 1) Readjustment of postural supports is allowed after each of the tests in [Clauses 8](#) and [9](#).
 - 2) Re-tightening, readjusting, or refitting of components that are identified in the operator's manual as operator-adjustable components is allowed at 25 % intervals during each of the multi drum, drop, and manual brake fatigue testing procedures ([Clause 10](#)). Operator adjustable components, as identified in the operator's manual, may not be adjusted using tools unless the tools are supplied with the wheelchair. If there are operator adjustable components, fatigue test equipment may be stopped at 25 % plus or minus 5 % intervals, to determine if re-tightening, readjusting, or refitting of operator-adjustable components is required. Re-tightening, readjusting, or refitting shall then be performed, following the procedures outlined in the operator's manual. Restart the test equipment after re-tightening, readjusting, or refitting has been performed.
 - 3) Re-tightening, readjusting, or refitting of any other component is not allowed.
 - 4) During the fatigue testing ([Clause 10](#)), the following wear items, if they are identified in the operator's manual, may be replaced no more than twice per item: tyres (including solid tyres), inner tubes, drive belts, castor wheel rubber. In the case of castor wheels that are a single integral part, replacement is only permitted because of wear or failure of the running surface, but not for failure of the wheel structure or other elements (e.g. bearings). No other wear items may be replaced.
 - 5) Cracks in surface finishes, such as paint, that do not extend into the structural material do not constitute a failure.
- b) No externally visible electrical cable shall be cut, abraded, or crushed. No externally visible electrical connector shall be crushed or disconnected.
- c) All parts intended to move, rotate or be removable, folding or adjustable shall operate as described by the manufacturer.
- d) All power-operated systems shall operate as described by the manufacturer.
- e) Handgrips shall not be displaced.
- f) No component or assembly of parts shall exhibit visible plastic deformation, free play, or loss of adjustment that adversely affects the function of the wheelchair.
- g) The brake mechanism shall not have moved from the pre-set positions.

4.2 Disclosure requirements

Manufacturers shall disclose in their specification sheets, in the manner and sequence specified in ISO 7176-15, if the wheelchair meets the strength requirements of this part of ISO 7176.

5 Test apparatus

5.1 Loading device, shall be capable of applying forces (compressive or tensile) to the wheelchair in the range 15 N to 2 000 N to an accuracy of $\pm 3\%$.

5.2 Concave loading pad, shall be made of metal or hard wood as shown in [Figure 1](#). If suitable, the concave loading pad specified in ISO 16840-3 may be used in place of the concave loading pad shown in [Figure 1](#).

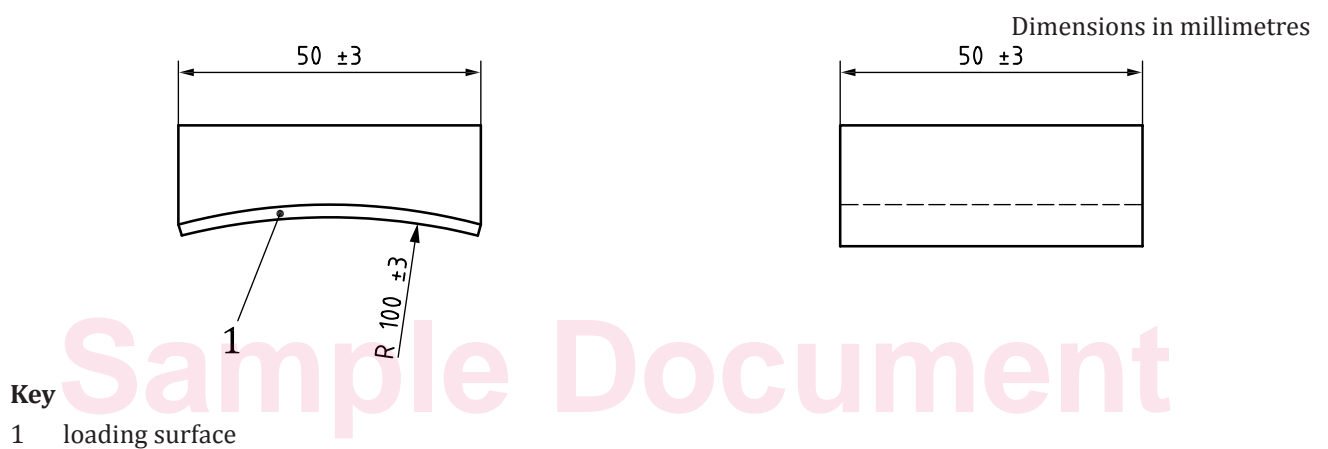

NOTE The loading surface may be covered with non-slip material up to 3 mm thick, e.g. plastic foam.

Figure 1 — Concave loading pad

5.3 Convex loading pad, has a cylindrical loading surface and shall be made of metal or hard wood, as shown in [Figure 2](#).

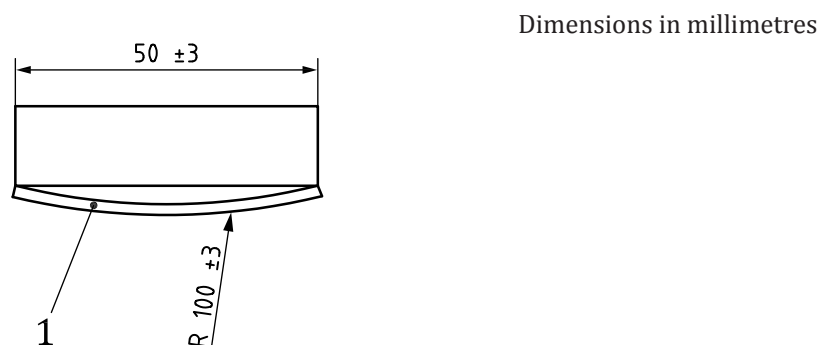

NOTE The loading surface may be covered with non-slip material up to 3 mm thick, e.g. plastic foam.

Figure 2 — Convex loading pad

5.4 **Horizontal test plane**, as specified in ISO 7176-22 shall be used.

5.5 **Back support impact test pendulum**, shall meet the requirements shown in [Figures 3](#) or [4](#) or achieve equivalent inertial performance.

The total mass of the ball/sphere shall be 25 kg \pm 0,5 kg.

Dimensions in millimetres

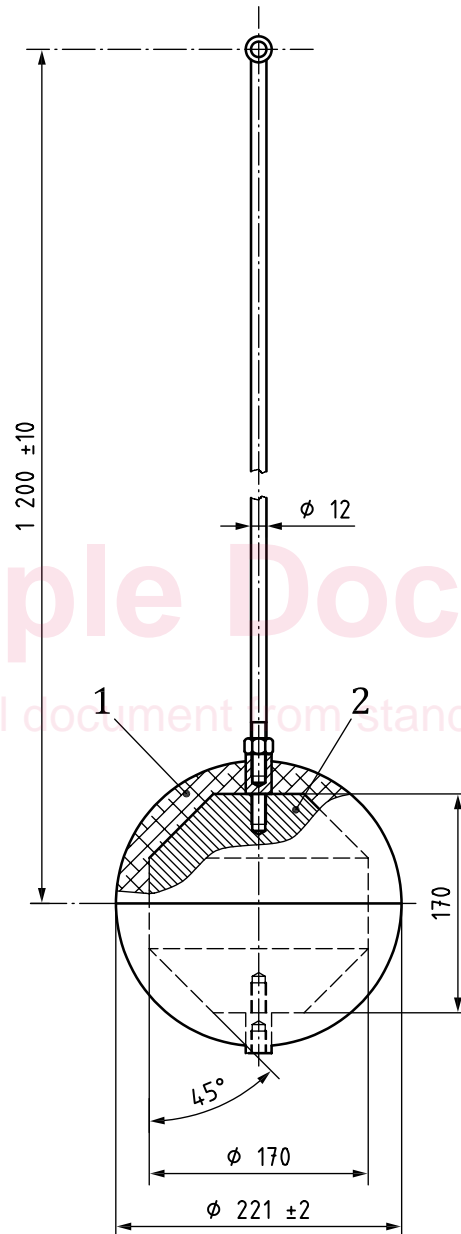

Key

- 1 polyurethane sphere with the following specifications: density 1 150 kg/m³; hardness 80+ shore A; resilience 20 %
- 2 steel

Figure 3 — Back support pendulum

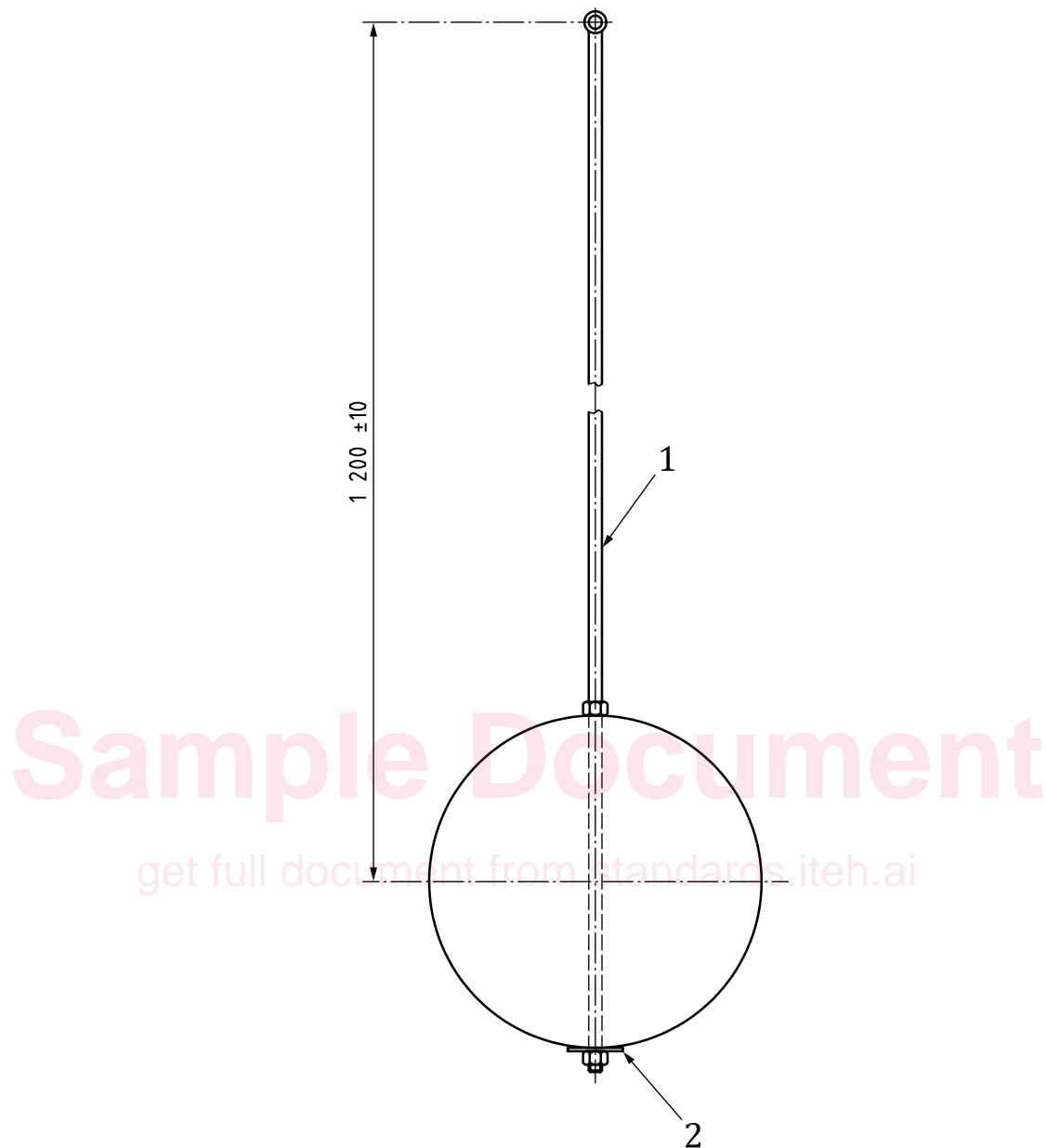
**Key**

Regulation association football with nominal diameter 220 mm (size 5 soccer ball), filled with lead shot $3,5 \pm 1$ mm diameter and lined with closed cell high-density foam of density $75 \text{ kg/m}^3 \pm 15 \text{ kg/m}^3$ (ISO 845) and hardness $325 \text{ N} \pm 60 \text{ N}$ (ISO 2439).

- 1 threaded bar
- 2 washer

Figure 4 — Alternate back support pendulum

5.6 Handrim impact test pendulum and castor and foot support impact test pendulum, shall

- a) have a total mass of $10 \text{ kg} \pm 0,20 \text{ kg}$, and
- b) meet the dimensional requirements shown in [Figure 5](#).

The steel block shall be capable of being rotated about the longitudinal axis of the steel tube.

The reference dimension and the position of the steel block on the tube shall be adjusted so that the distance (d_1) from pivot to position of the centre of percussion is 1 000 mm \pm 1 mm when calculated using Formula (1):

$$d_1 = \frac{I}{MR} \quad (1)$$

where

- d_1 is the distance from the pivot to the centre of percussion, expressed in metres;
- I is the moment of inertia of the pendulum about its pivot, expressed in kilogram meters squared (kg m²);
- M is the pendulum mass, expressed in kilograms;
- R is the distance from the pivot to the centre of mass, expressed in metres.

NOTE 1 The same impact test pendulum shown in [Figure 5](#) may be used for handrim, foot support, and castor impact testing, although other shapes or orientations may be required to accommodate small castors.

NOTE 2 See [Annex A](#) for the application of Formula (1).

Sample Document

get full document from standards.iteh.ai

