Zahteve za vzporedno vezavo generatorskih postrojev z javnim nizkonapetostnim razdelilnim omrežjem - 10. del: Preskusi za oceno skladnosti generatorskih enot

Requirements for generating plants to be connected in parallel with distribution networks
- Part 10: Tests for conformity assessment of generating units

Anforderungen für zum Parallelbetrieb mit einem Verteilnetz vorgesehene Erzeugungsanlagen - Teil 10: Prüfanforderungen für die Konformitätsbeurteilung von Erzeugungseinheiten

Exigences relatives aux centrales électriques destinées à être raccordées en parallèle à des réseaux de distribution - Partie 10: Essais d'évaluation de la conformité des unités de production

Ta slovenski standard je istoveten z: prEN 50549-10:2026

ICS:

29.160.20	Generatorji	Generators
29.240.01	Omrežja za prenos in distribucijo električne energije na splošno	Power transmission and distribution networks in general

oSIST prEN 50549-10:2026

en,fr,de

Sample Document

get full document from standards.iteh.ai

EUROPEAN STANDARD
NORME EUROPÉENNE
EUROPÄISCHE NORM

DRAFT
prEN 50549-10

May 2026

ICS 29.160.20

Will supersede EN 50549-10:2022

English Version

**Requirements for generating plants to be connected in parallel
with distribution networks - Part 10: Tests for conformity
assessment of generating units**

To be completed

To be completed

This draft European Standard is submitted to CENELEC members for enquiry.
Deadline for CENELEC: 2026-08-14.

It has been drawn up by CLC/TC 8X.

If this draft becomes a European Standard, CENELEC members are bound to comply with the CEN/CENELEC Internal Regulations which stipulate the conditions for giving this European Standard the status of a national standard without any alteration.

This draft European Standard was established by CENELEC in three official versions (English, French, German).
A version in any other language made by translation under the responsibility of a CENELEC member into its own language and notified to the CEN-CENELEC Management Centre has the same status as the official versions.

CENELEC members are the national electrotechnical committees of Austria, Belgium, Bulgaria, Croatia, Cyprus, the Czech Republic, Denmark, Estonia, Finland, France, Germany, Greece, Hungary, Iceland, Ireland, Italy, Latvia, Lithuania, Luxembourg, Malta, the Netherlands, Norway, Poland, Portugal, Republic of North Macedonia, Romania, Serbia, Slovakia, Slovenia, Spain, Sweden, Switzerland, Türkiye and the United Kingdom.

Recipients of this draft are invited to submit, with their comments, notification of any relevant patent rights of which they are aware and to provide supporting documentation.

Warning : This document is not a European Standard. It is distributed for review and comments. It is subject to change without notice and shall not be referred to as a European Standard.



European Committee for Electrotechnical Standardization
Comité Européen de Normalisation Electrotechnique
Europäisches Komitee für Elektrotechnische Normung

CEN-CENELEC Management Centre: Rue de la Science 23, B-1040 Brussels

© 2026 CENELEC All rights of exploitation in any form and by any means reserved worldwide for CENELEC Members.

Project: 78903

Ref. No. prEN 50549-10:2026 E

26	Contents	Page
27	European foreword	5
28	1 Scope	6
29	2 Normative references	6
30	3 Terms, definitions, symbols and abbreviations	8
31	3.1 General	8
32	3.2 Plant, module and unit	9
33	3.3 Power	13
34	3.4 Circuit theory	14
35	3.5 Protection	14
36	3.6 Control	15
37	3.7 Power Quality	15
38	3.8 Symbols and abbreviations	16
39	4 Assessment methods and test equipment	17
40	4.1 General	17
41	4.2 Assessment methods	18
42	4.2.1 Test on complete generating unit	18
43	4.2.2 Test on the electrical generation system	18
44	4.2.3 Test on the nacelle of a wind turbine	19
45	4.2.4 Test on the primary energy converter	19
46	4.2.5 Test at limited power	19
47	4.2.6 Test on a stopped generating unit	20
48	4.2.7 Test on an independent component	20
49	4.2.8 Simulated input test	20
50	4.2.9 Test by changing a control parameter	21
51	4.2.10 Field measurements	22
52	4.2.11 Test by calculation and numerical simulation for generating units of synchronous generating technology	22
53	4.2.12 Test of the real generating unit control unit in a simulated environment (“Controller-Hardware-in-the-loop” (CHIL) test)	22
54	4.2.13 Evaluation by inspection and test of dependent components	22
55	4.3 Requirements for the measuring equipment	23
56	4.4 Configuration range and parameter sets	26
57	4.4.1 General	26
58	4.4.2 Documentation	28
59	4.5 EUT Software change requirements	28
60	4.6 Transferability of test results to identical or similar generating units or components	29
61	4.6.1 General	29
62	4.6.2 Synchronous generating technology	30
63	4.6.3 Non-synchronous generation technology – Wind power generating units	31
64	4.6.4 Non-synchronous generation technology – Inverter based (photovoltaic or other non-wind)	36
65	4.6.5 Protection systems associated to any generating unit	37
66	5 Testing	37
67	5.1 General	37
68	5.2 Normal operating range	38
69	5.2.1 Frequency operating range	38
70	5.2.2 Voltage operating range	41
71	5.3 Immunity to disturbances	44
72	5.3.1 Rate of change of frequency (ROCOF)	44
73	5.3.2 Phase jump	48
74	5.3.3 Fault ride through, over voltage (OVRT) and under voltage (UVRT)	50

78	5.4	Active response to frequency deviation	61
79	5.4.1	General	61
80	5.4.2	Test application and verification methodology	61
81	5.4.3	Verification procedure	63
82	5.4.4	Assessment criteria	75
83	5.4.5	Documentation	76
84	5.5	Power capabilities and response to voltage variations	76
85	5.5.1	Power capabilities assessment and voltage support by reactive power	76
86	5.5.2	Voltage support by reactive power - test to determine the reactive power control modes	84
87	5.6	Voltage related active power reduction - P(U)	99
88	5.6.1	General	99
89	5.6.2	Test application and verification	100
90	5.6.3	Test procedure for steady state behaviour	100
91	5.6.4	Test procedure for dynamic behaviour	100
92	5.6.5	Assessment criteria	101
93	5.6.6	Documentation	101
94	5.7	EMC and power quality	102
95	5.7.1	EMC	102
96	5.7.2	Power quality	103
97	5.8	Interface protection	107
98	5.8.1	General	107
99	5.8.2	Test application and verification methodology	108
100	5.8.3	Verification procedure for generating plants to be connected to a LV distribution network with Interface protection as internal function	109
101			
102	5.8.4	Verification procedure for generating plants to be connected to a LV distribution network with Interface protection as dedicated device	124
103			
104	5.8.5	Verification procedure for generating plants to be connected to a MV distribution network	124
105			
106	5.8.6	Islanding detection	125
107	5.9	Connection and starting	125
108	5.9.1	General	125
109	5.9.2	Test application and verification methodology	126
110	5.9.3	Automatic reconnection after tripping	127
111	5.9.4	Starting to generate electrical power	129
112	5.9.5	Assessment criteria	129
113	5.9.6	Documentation	130
114	5.9.7	Synchronisation	130
115	5.10	Active power reduction on set point	130
116	5.10.1	General	130
117	5.10.2	Test application and verification methodology	131
118	5.10.3	Verification procedure	132
119	5.11	Remote information exchange	139
120	5.12	Requirements regarding single fault tolerance of interface protection system and interface switch	139
121			
122	5.12.1	General	139
123	5.12.2	Single fault tolerance of the interface protection system	139
124	5.12.3	Single fault tolerance of the interface switch	140
125	5.13	Model definition and model validation for generating units of synchronous generating technology	141
126			
127	5.13.1	General	141
128	5.13.2	Model definition	141
129	5.13.3	Verification environment	143
130	5.13.4	Verification process	145
131	Annex A (normative)	Fault ride through test setup	164
132	A.1	Example UVRT test setup	164
133	A.2	Example OVRT test setup	164
134	A.3	AC grid simulator converter system	165
135	Annex B (normative)	Template for statements of conformity and parameters	168

prEN 50549-10:2026 (E)

136	B.1	General	168
137	B.2	Templates for statements of conformity	168
138	Annex C (informative)	Table 8 of EN 61000-4-13: 2002 + A1:2009 + A2:2016 and Table 26 of EN IEC	
139		60255-181:2019	175
140	C.1	Table 26 of EN IEC 60255-181:2019	175
141	C.2	Table 8 of EN 61000-4-13:2002 + A1:2009 + A2:2016	176
142	Annex D (informative)	Sign convention - Generator convention of the signs	178
143	Bibliography		179
144			

Sample Document

get full document from standards.iteh.ai

145 **European foreword**

146 This document (prEN 50549-10:2026) has been prepared by CLC/TC 8X "*System aspects of electrical energy*
147 *supply*".

148 This document is currently submitted to the Enquiry

149 The following dates are proposed:

- latest date by which the existence of this (doa) dav + 6 months
document has to be announced at national level
- latest date by which this document has to be (dop) dav + 12 months
implemented at national level by publication of
an identical national standard or by
endorsement
- latest date by which the national standards (dow) dav + 36 months
conflicting with this document have to be (to be confirmed or
withdrawn modified when voting)

150 This document will supersede EN 50549-10:2022 and all of its amendments and corrigenda (if any).

151 prEN 50549-10:2026 includes the following significant technical changes with respect to EN 50549-10:2022:

- 152 – update and improvement of complete document.
- 153 – main technical development:
- 154 – modification regarding A1:2023 of EN 50549-1 and EN 50549-2.
- 155 – Clause 4.6. added "Transferability of test results to identical or similar generating units or
156 components".

prEN 50549-10:2026 (E)157 **1 Scope**

158 The purpose of this document is to provide technical guidance for tests on generating units, interface
159 protection and generating plant controller to evaluate their electrical characteristics.

160 NOTE 1 Mechanical issues are taken into account as far as they influence the electrical characteristics.

161 NOTE 2 Electrical energy storage systems (EESS) in meeting the conditions of 50549-1 and 50549-2 are considered as
162 generating units.

163 The evaluation results are intended to be used to demonstrate conformity of generating units, interface
164 protection and generating plant controller to technical requirements for grid connection. In this context
165 the evaluation results can also be used as part of a certification programme.

166 NOTE 3 Besides the type test results of the generating units, interface protection and generating plant controller all additional
167 elements for connection to the grid (e.g. transformer, cabling, multiple units) are considered in the evaluation of the final
168 installation of a generating plant.

169 The requirements intended to be evaluated are covered in the following standardization documents:

- 170 – EN 50549-1:2019: Requirements for generating plants to be connected in parallel with distribution
171 networks - Part 1: connection to a LV distribution network - Generating plants up to and including
172 Type B
- 173 – EN 50549-2:2019: Requirements for generating plants to be connected in parallel with distribution
174 networks - Part 2: Connection to a MV distribution network - Generating plants up to and including
175 Type B

176 If grid connection requirements are dealt with in other documents or for other generating module types,
177 where no specific testing procedure is provided, the testing methods described in this document can
178 be used, if applicable.

179 This document provides evaluation criteria for the conformity assessment of generating units with
180 respect to the above mentioned standardization documents, based on type testing. However, some
181 requirements are applicable on the generating plant level. The assessment of the conformity to these
182 plant requirements is out of scope of this document. Nevertheless, this document can be used to show
183 the capabilities of a generating unit to be used in a generating plant.

184 As a consequence, it is possible that the conformity assessment of a generating unit does not cover
185 all aspects of the above mentioned standardization documents, typically when a requirement is
186 evaluated on plant level. Therefore, the conformity assessment report indicates clearly which clauses
187 of this document are covered and which clauses are not covered.

188 This document recognizes the existence of specific technical test requirements within several member
189 states and these must be complied with.

190 **2 Normative references**

191 The following documents are referred to in the text in such a way that some or all of their content
192 constitutes requirements of this document. For dated references, only the edition cited applies. For
193 undated references, the latest edition of the referenced document (including any amendments) applies.

194 EN 50524, *Data sheet for photovoltaic inverters*

195 EN 50549-1:2019¹, *Requirements for generating plants to be connected in parallel with distribution*
196 *networks – Part 1: connection to a LV distribution network - Generating plants up to and including Type*
197 *B*

¹ As impacted by EN 50549-1:2019/AC2019-04 and EN 50549-1:2019/A1:2023.

- 198 EN 50549-2:2019², *Requirements for generating plants to be connected in parallel with distribution*
 199 *networks – Part 2: Connection to a MV distribution network - Generating plants up to and including*
 200 *Type B*
- 201 EN IEC 60034 (all parts), *Rotating electrical machines (IEC 60034)*
- 202 EN IEC 60255-1, *Measuring relays and protection equipment – Part 1: Common requirements*
 203 *(IEC 60255-1)*
- 204 EN IEC 60255-26:2025, *Measuring relays and protection equipment – Part 26: Electromagnetic*
 205 *compatibility requirements (IEC 60255-26:2023)*
- 206 EN 60255-27, *Measuring relays and protection equipment – Part 27: Product safety requirements*
 207 *(IEC 60255-27)*
- 208 EN 60255-127, *Measuring relays and protection equipment – Part 127: Functional requirements for*
 209 *over/under voltage protection (IEC 60255-127)*
- 210 EN IEC 60255-181:2019, *Measuring relays and protection equipment – Part 181: Functional*
 211 *requirements for frequency protection (IEC 60255-181:2019)*
- 212 EN 60730-1:2016³, *Automatic electrical controls – Part 1: General requirements (IEC 60730-1:2013)*
- 213 EN IEC 61000-3-2, *Electromagnetic compatibility (EMC) – Part 3-2: Limits – Limits for harmonic current*
 214 *emissions (equipment input current ≤ 16 A per phase) (IEC 61000-3-2)*
- 215 EN 61000-3-3, *Electromagnetic compatibility (EMC) - Part 3-3: Limits - Limitation of voltage changes,*
 216 *voltage fluctuations and flicker in public low-voltage supply systems, for equipment with rated current*
 217 *≤ 16 A per phase and not subject to conditional connection (IEC 61000-3-3)*
- 218 EN IEC 61000-3-11, *Electromagnetic compatibility (EMC) – Part 3-11: Limits – Limitation of voltage*
 219 *changes, voltage fluctuations and flicker in public low-voltage supply systems – Equipment with rated*
 220 *current ≤ 75 A and subject to conditional connection (IEC 61000-3-11)*
- 221 EN 61000-3-12, *Electromagnetic compatibility (EMC) – Part 3-12: Limits - Limits for harmonic currents*
 222 *produced by equipment connected to public low-voltage systems with input current >16 A and ≤ 75 A*
 223 *per phase (IEC 61000-3-12)*
- 224 EN 61000-4-7:2002⁴, *Electromagnetic compatibility (EMC) – Part 4-7: Testing and measurement*
 225 *techniques - General guide on harmonics and interharmonics measurements and instrumentation, for*
 226 *power supply systems and equipment connected thereto (IEC 61000-4-7:2002)*
- 227 EN 61000-4-13:2002⁵, *Electromagnetic compatibility (EMC) – Part 4-13: Testing and measurement*
 228 *techniques - Harmonics and interharmonics including mains signalling at a.c. power port, low frequency*
 229 *immunity tests (IEC 61000-4-13:2002)*
- 230 EN 61508-3:2010, *Functional safety of electrical/electronic/programmable electronic safety-related*
 231 *systems – Part 3: Software requirements (IEC 61508-3:2010)*
- 232 EN 61869-2, *Instrument transformers – Part 2: Additional requirements for current transformers*
 233 *(IEC 61869-2)*

² As impacted by EN 50549-2:2019/AC2019-03 and EN 50549-2:2019/A1:2023.

³ As impacted by EN 60730-1:2016/A1:2019, EN 60730-1:2016/A2:2022, EN 60730-1:2016/A11:2024 and EN 60730-1:2016/A11:2024/AC:2025-07.

⁴ As impacted by EN 61000-4-7:2002/A1:2009.

⁵ As impacted by EN 61000-4-13:2002/A1:2009 and EN 61000-4-13:2002/A2:2016.

prEN 50549-10:2026 (E)

234 EN 61869-3, *Instrument transformers – Part 3: Additional requirements for inductive voltage*
235 *transformers (IEC 61869-3)*

236 EN 62116, *Utility-interconnected photovoltaic inverters - Test procedure of islanding prevention*
237 *measures (IEC 62116)*

238 EN 62109-2, *Safety of power converters for use in photovoltaic power systems – Part 2: Particular*
239 *requirements for inverters (IEC 62109-2)*

240 IEC TS 61400-21-4, *Wind energy generation systems – Part 21-4: Measurement and assessment of*
241 *electrical characteristics – Wind turbine components and subsystems*

242 UL 1998:2013, *Software in Programmable Components*

243 *FGW TR 4, Requirements for modelling and validation of simulation models of electrical characteristics*
244 *of generation units and plants, storage facilities and their components.*

245 *REE NTS, Technical Standard for Monitoring the Conformity of Power Generation Modules according*
246 *to EU Regulation 2016/631*

247 **3 Terms, definitions, symbols and abbreviations**

248 For the purposes of this document, the terms and definitions given in EN 50549-1:2019, EN 50549-
249 2:2019 and the following apply.

250 ISO and IEC maintain terminological databases for use in standardization at the following addresses:

- 251 • IEC Electropedia: available at <http://www.electropedia.org/>
- 252 • ISO Online browsing platform: available at <http://www.iso.org/obp>

253 NOTE 1 The terms and definitions given in this clause are structured in the same way as the terms and definitions of EN
254 50549-1:2019 and EN 50549-2:2019.

255 NOTE 2 Terms and definitions are selected to achieve consistency with IEV (cf. www.electropedia.org) and CENELEC
256 terminology, recognizing that terms in COMMISSION REGULATION (EU) 2016/631 can deviate.

257 **3.1 General**

258 **3.1.1**

259 **relevant party**

260 stakeholder having a role and responsibility in the different conformity procedures in place within
261 different EU countries

262 EXAMPLE TSOs, DSOs, certifiers, measuring institutes, manufacturers, etc.

263 **3.1.2**

264 **manufacturer**

265 organisation, situated at a stated location or stated locations that carries out or controls such stages
266 in the process of bringing a product to the market as manufacture, assessment, verification, handling
267 and storage of a product

268 Note 1 to entry: A Manufacturer has full responsibility for continued compliance of the product until delivery to the customer
269 with the relevant requirements and undertakes all obligations in this regard.

270 [SOURCE: IECRE Definitions, modified – Limitation until delivery to the customer added.]

271 **3.1.3**

272 **conformity**

273 fulfilment of a requirement

274 [SOURCE: IEV 192-01-15]

275 **3.1.4**
 276 **verification**
 277 confirmation, through the provision of objective evidence, that specified requirements have been
 278 fulfilled

279 Note 1 to entry: The term “verified” is used to designate the corresponding status.

280 Note 2 to entry: Design verification is the application of tests and appraisals to assess conformity of a design to the specified
 281 requirement.

282 Note 3 to entry: In the case of software, verification is conducted at various stages of development, examining the software
 283 and its constituents to determine conformity to the requirements specified at the beginning of that stage.

284 [SOURCE: IEC 192-01-17]

285 **3.1.5**
 286 **conformity assessment**
 287 demonstration that specified requirements relating to a product, process, system, person or body are
 288 fulfilled

289 Note 1 to entry: The subject field of conformity assessment includes activities defined elsewhere in ISO/IEC 17000, such as
 290 testing, inspection and certification, as well as the accreditation of conformity assessment bodies.

291 Note 2 to entry: The expression “object of conformity assessment” or “object” is used in ISO/IEC 17000 to encompass any
 292 particular material, product, installation, process, system, person or body to which conformity assessment is applied. A service
 293 is covered by the definition of a product (see Note 1 to IEC 902-02-03).

294 [SOURCE: IEC 902-01-01]

295 **3.1.6**
 296 **conformity evaluation**
 297 systematic examination of the extent to which a product, process or service fulfils specified
 298 requirements

299 [SOURCE: IEC 151-16-14]

300 **3.1.7**
 301 **validation**
 302 <simulation model> assessment of the accuracy level of the simulation model to represent the real
 303 system for a specific purpose

304 **3.2 Plant, module and unit**

305 **3.2.1**
 306 **type test**
 307 conformity test made on one or more items representative of the product family

308 [SOURCE: IEC 151-16-16]

309 **3.2.2**
 310 **measuring equipment**
 311 assembly of measuring instruments intended for specified measurement purposes

312 [SOURCE: IEC 311-03-05]

313 **3.2.3**
 314 **test equipment**
 315 equipment that is added to a test setup for the purpose of testing and measuring during the test

316 Note 1 to entry: This includes among others specific impedances, FRT-test equipment, measurement equipment, grid-
 317 simulator as applicable.

318 **3.2.4**
 319 **test set-up**
 320 electrical system where the test is carried out

prEN 50549-10:2026 (E)

321 Note to entry 1: This includes among others, grid-characteristics at POC, transformers, cables, test equipment as applicable.

322 **3.2.5**323 **grid simulator**

324 programmable AC power supply, capable of emulating various grid conditions to facilitate the testing
325 of grid-connected equipment.

326 **3.2.6**327 **generating unit under test**328 **GUT**

329 generating unit subjected to tests

330 **3.2.7**331 **equipment under test**332 **EUT**

333 equipment (products, devices, components and systems) subjected to tests

334 **3.2.8**335 **component**

336 constituent part of a device which cannot be physically divided into smaller parts without losing its
337 particular function

338 [SOURCE: IEC 60050-111-21]

339 **3.2.9**340 **primary energy converter**

341 device or system that converts any form of energy into either electrical or mechanical energy as part
342 of the conversion to AC electricity

343 EXAMPLE PV generator; fuel driven engines; gas, steam or water turbines; aerodynamic system of a wind turbine.

344 **3.2.10**345 **on-load tap-changer**346 **load-tap-changer (US)**347 **OLTC**

348 device for changing the tapping connections of a winding, suitable for operation while the transformer
349 is energized or on load

350 [SOURCE: IEC 60050-111-01, modified – An abbreviation was added.]

351 **3.2.11**352 **software**

353 assembly of programs, procedures, rules, documentation and data, pertaining to the operation of an
354 information processing device or system

355 EXAMPLE Firmware, operating system, application software.

356 Note 1 to entry Software is an intellectual creation that is independent of the medium upon which it is recorded.

357 Note 2 to entry Software requires hardware to execute programs, and to store and transmit data.

358 [SOURCE: IEC 60050-111-21]

359 **3.2.12**360 **Hardware-in-the-Loop**361 **HIL**

362 simulation method that allows an equipment under test to interact in a closed loop with a real time
363 simulation model

364 Note 1 to entry: See also Figure 1.

365 Note 2 to entry: Some parts of the system may not be present in all technologies e.g. no mechanical part in PV system or no
366 power electronics in synchronous coupled generating unit.

367 **3.2.13**
368 **Control Hardware-in-the-Loop**
369 **CHIL**
370 HIL where the real-time simulation model interfaces the equipment under test on signal level

371 Note 1 to entry: See also Figure 1.

372 **3.2.14**
373 **Power Hardware-in-the-Loop**
374 **PHIL**
375 HIL where the real-time simulation model interfaces the equipment under test on electrical power level
376 and if applicable on signal level

377 Note 1 to entry: See also Figure 1.

378 **3.2.15**
379 **Mechanical Hardware-in-the-Loop**
380 **MHIL**
381 HIL where the real-time simulation model interfaces the equipment under test on mechanical level and
382 if applicable on signal level

383 Note 1 to entry: See also Figure 1.

Sample Document

get full document from standards.iteh.ai

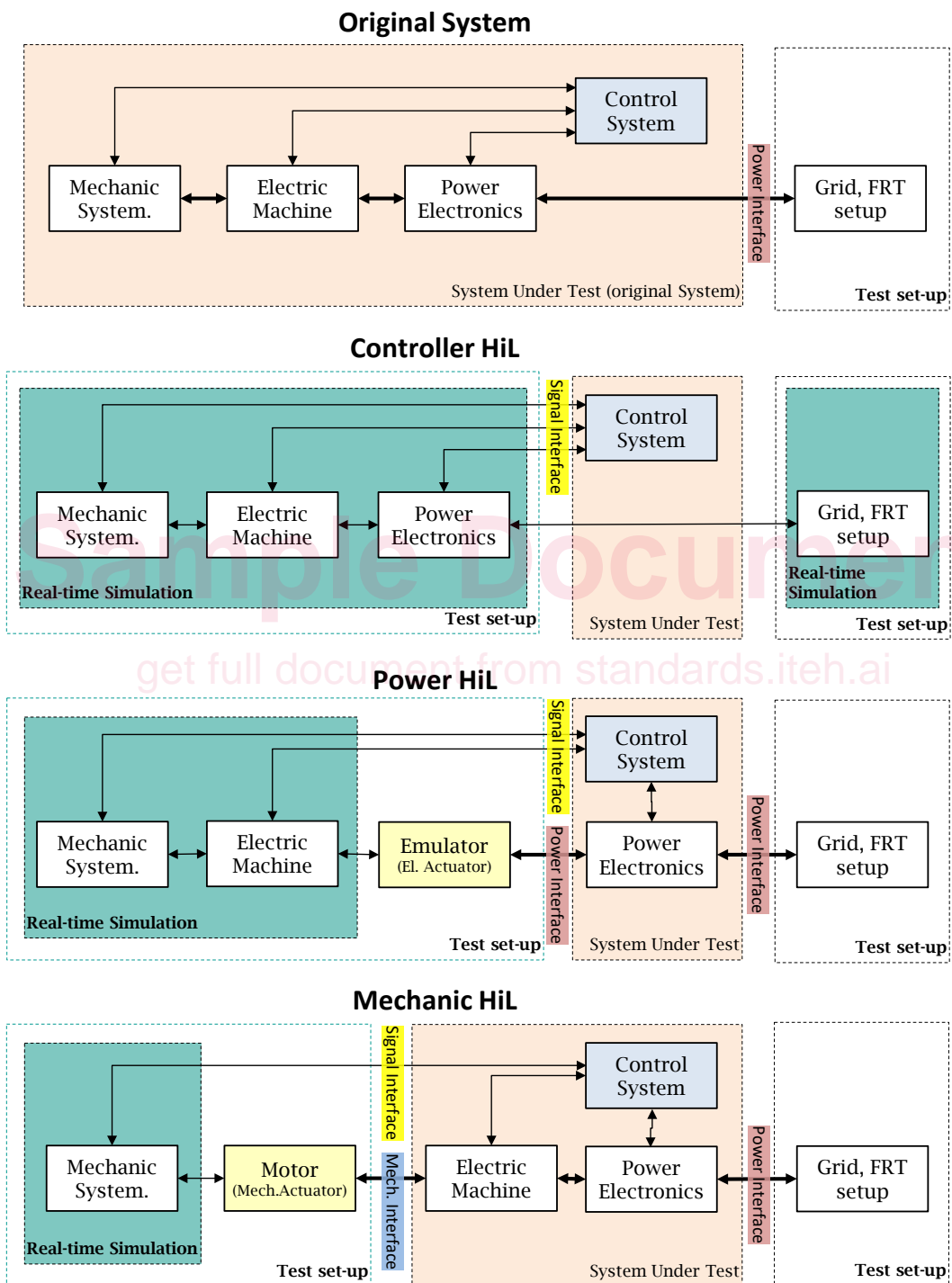

Figure 1 – Hardware in the loop test set up

384

385

386 **3.3 Power**387 **3.3.1**388 **nominal power**389 **P_n**

390 nominal value of a generating unit's active power, which is stated by the manufacturer

391 **3.3.2**392 **nominal current**393 **I_n** 394 nominal value I_n of generating unit, either as stated by the manufacturer or which shall be calculated
395 from nominal apparent power S_n and nominal voltage U_n according to

396
$$I_n = \frac{S_n}{\sqrt{3} U_n}$$

397 Note 1 to entry If no nominal active factor is specified it is assumed to be 1.

398 [SOURCE: IEC 61400-27, ed. 1.0 (2015-02) 3.1.6, modified – Applicable for generating units,
399 manufacturer statement and active factor added.]400 **3.3.3**401 **minimum regulating level**402 minimum active power, as specified by the manufacturer down to which the generating unit can control
403 active power404 Note 1 to entry: In special cases, generating units of non-synchronous generating technology also have a minimum technical
405 power.406 Note 2 to entry: The minimum regulating level of a power generating plant is to be determined in a suitable manner based on
407 the minimum regulating levels of the power generating units.408 [SOURCE: COMMISSION REGULATION 2016/631 Article 2 (24) modified – RfG definition adopted to
409 the formal terminology structure in CLC standards and two notes have been added.]410 **3.3.4**411 **maximum reactive power**412 **$Q_{\text{max over}}$** 413 <over excited> maximum continuous over excited reactive power, measured in a 10 min average, which
414 a generating unit or the sum of all the generating units in a generating plant can exchange as specified
415 in the connection agreement or as agreed between the responsible party or the DSO and the
416 generating plant operator417 Note 1 to entry: In some configurations Q_{max} is not available for all active power operating points.418 **3.3.5**419 **maximum reactive power**420 **$Q_{\text{max under}}$** 421 <under excited> maximum continuous under excited reactive power, measured in a 10 min average,
422 which a generating unit or the sum of all the generating units in a generating plant can exchange as
423 specified in the connection agreement or as agreed between the responsible party or the DSO and the
424 generating plant operator425 Note to entry: In some configurations Q_{max} is not available for all active power operating points.426 **3.3.6**427 **short-circuit power**428 **S_k** 429 the product of the current in the short circuit at a point of a system and a conventional voltage, generally
430 the operating voltage

431 [SOURCE: IEC 601-01-14]