**Neelektrična ročna orodja - Varnostne zahteve - 13. del: Orodja za pritrjevanje
(ISO/DIS 11148-13:2026)**

Hand-held non-electric power tools - Safety requirements - Part 13: Fastener driving tools (ISO/DIS 11148-13:2026)

Handgehaltene nicht-elektrisch betriebene Maschinen - Sicherheitsanforderungen - Teil 13: Eintreibgeräte (ISO/DIS 11148-13:2026)

Machines portatives à moteur non électrique - Exigences de sécurité - Partie 13: Machines à enfoncer les fixations (ISO/DIS 11148-13:2026)

Ta slovenski standard je istoveten z: prEN ISO 11148-13

ICS:

25.140.10 Pnevmatična orodja Pneumatic tools

oSIST prEN ISO 11148-13:2026 en,fr,de

Sample Document

get full document from standards.iteh.ai



DRAFT International Standard

ISO/DIS 11148-13

Hand-held non-electric power tools — Safety requirements —

Part 13: Fastener driving tools

*Machines portatives à moteur non électrique — Exigences de
sécurité —*

Partie 13: Machines à enfoncer les fixations

ICS: 25.140.10

ISO/TC 118/SC 3

Secretariat: **SIS**

Voting begins on:
2026-05-04

Voting terminates on:
2026-07-27

This document is circulated as received from the committee secretariat.

ISO/CEN PARALLEL PROCESSING

Reference number
ISO/DIS 11148-13:2026(en)

THIS DOCUMENT IS A DRAFT CIRCULATED FOR COMMENTS AND APPROVAL. IT IS THEREFORE SUBJECT TO CHANGE AND MAY NOT BE REFERRED TO AS AN INTERNATIONAL STANDARD UNTIL PUBLISHED AS SUCH.

IN ADDITION TO THEIR EVALUATION AS BEING ACCEPTABLE FOR INDUSTRIAL, TECHNOLOGICAL, COMMERCIAL AND USER PURPOSES, DRAFT INTERNATIONAL STANDARDS MAY ON OCCASION HAVE TO BE CONSIDERED IN THE LIGHT OF THEIR POTENTIAL TO BECOME STANDARDS TO WHICH REFERENCE MAY BE MADE IN NATIONAL REGULATIONS.

RECIPIENTS OF THIS DRAFT ARE INVITED TO SUBMIT, WITH THEIR COMMENTS, NOTIFICATION OF ANY RELEVANT PATENT RIGHTS OF WHICH THEY ARE AWARE AND TO PROVIDE SUPPORTING DOCUMENTATION.

© ISO 2026

Sample Document

get full document from standards.iteh.ai



COPYRIGHT PROTECTED DOCUMENT

© ISO 2026

All rights reserved. Unless otherwise specified, or required in the context of its implementation, no part of this publication may be reproduced or utilized otherwise in any form or by any means, electronic or mechanical, including photocopying, or posting on the internet or an intranet, without prior written permission. Permission can be requested from either ISO at the address below or ISO's member body in the country of the requester.

ISO copyright office
CP 401 • Ch. de Blandonnet 8
CH-1214 Vernier, Geneva
Phone: +41 22 749 01 11
Email: copyright@iso.org
Website: www.iso.org

Published in Switzerland

© ISO 2026 – All rights reserved

ISO/DIS 11148-13:2026(en)

Contents

	Page
Foreword	v
Introduction	vi
1 Scope	1
2 Normative references	1
3 Terms and definitions	2
4 Safety requirements and measures	8
4.1 General.....	8
4.2 Mechanical safety.....	8
4.2.1 Protection against points and edges of fasteners.....	8
4.2.2 Prevention of unintended ejection of fasteners.....	8
4.2.3 Prevention of free flight of fasteners.....	9
4.2.4 Design of the workpiece contact.....	9
4.2.5 Permitted trigger actuation modes.....	11
4.2.6 Strength of the fastener driving tool.....	12
4.2.7 Surfaces, edges and corners.....	12
4.2.8 Stability.....	12
4.2.9 Hose fittings.....	13
4.2.10 Unintentional change of actuation mode.....	13
4.3 Electrical safety.....	13
4.4 Thermal safety.....	13
4.4.1 Hot surfaces.....	13
4.4.2 Cold surfaces.....	13
4.5 Noise reduction.....	13
4.6 Mechanical impact (vibration/recoil).....	14
4.7 Materials and substances processed, used or emitted.....	14
4.7.1 Collating material residues.....	14
4.7.2 Discharged air, gas and lubricants.....	14
4.8 Ergonomics.....	15
4.8.1 Weight and control of the fastener driving tool.....	15
4.8.2 Handle design.....	15
4.9 User information.....	15
4.9.1 Fastener driving tool markings.....	15
4.9.2 Fastener driving tool operating instructions.....	15
4.10 Fire and explosion.....	15
4.10.1 Hazardous energy supplies for pneumatic fastener driving tools.....	15
4.10.2 Release of flammable gas from gas fastener driving tools and gas containers.....	16
4.10.3 Rupture due to high temperatures in the fastener driving tool.....	16
5 Verification	16
5.1 General.....	16
5.2 Protection against mechanical hazards.....	16
5.2.1 Protection against points and edges of fasteners.....	16
5.2.2 Prevention of unintended ejection of fasteners.....	17
5.2.3 Prevention of free flight of fasteners.....	18
5.2.4 Design of the workpiece contact.....	18
5.2.5 Actuation modes.....	19
5.2.6 Strength of the fastener driving tool.....	22
5.2.7 Surfaces, edges and corners.....	22
5.2.8 Stability.....	22
5.2.9 Hose Fittings.....	22
5.2.10 Unintentional change of actuation mode.....	22
5.3 Electrical safety.....	23
5.4 Thermal safety.....	23
5.4.1 Hot surfaces.....	23

ISO/DIS 11148-13:2026(en)

5.4.2	Cold surfaces.....	23
5.5	Noise.....	23
5.6	Mechanical impact (vibration/recoil).....	23
5.7	Materials and substances processed, used or emitted.....	24
5.7.1	Collating material residues.....	24
5.7.2	Discharged air, gas and lubricants.....	24
5.8	Ergonomics.....	24
5.8.1	Weight and control of the tool.....	24
5.8.2	Handle design.....	24
5.9	User information.....	24
5.9.1	Tool marking.....	24
5.9.2	Fastener driving tool operating instructions.....	24
5.10	Fire and explosion.....	24
5.10.1	Hazardous energy supplies for fastener driving tools.....	24
5.10.2	Release of flammable gas from gas fastener driving tools and gas containers.....	25
5.10.3	Rupture test for gas containers at high temperature.....	26
5.11	Structure of verification.....	27
6	Information for use.....	28
6.1	Markings.....	28
6.2	Instruction handbook.....	29
6.2.1	General.....	29
6.2.2	Safety rules.....	30
6.2.3	Hazards and Warnings.....	33
6.2.4	Maintenance instructions.....	35
	Annex A (informative) List of significant hazards.....	37
	Annex B (informative) Example of fastener driving tools covered by ISO 11148-13.....	40
	Annex C (normative) Symbols for labels and signs.....	41
	Annex D (normative) Warnings and symbols for labels and signs for fastener driving tools with contact actuation capability.....	42
	Annex E (informative) Information on the ergonomic design of the handle.....	44
	Annex F (informative) Noise test code.....	45
	Annex G (informative) Symbols for labels and signs for tools with automatic reversion.....	52
	Annex ZA (informative) Relationship between this European Standard and the essential requirements of Regulation (EU) 2023/1230 aimed to be covered.....	53
	Bibliography.....	57

ISO/DIS 11148-13:2026(en)

Foreword

ISO (the International Organization for Standardization) is a worldwide federation of national standards bodies (ISO member bodies). The work of preparing International Standards is normally carried out through ISO technical committees. Each member body interested in a subject for which a technical committee has been established has the right to be represented on that committee. International organizations, governmental and non-governmental, in liaison with ISO, also take part in the work. ISO collaborates closely with the International Electrotechnical Commission (IEC) on all matters of electrotechnical standardization.

The procedures used to develop this document and those intended for its further maintenance are described in the ISO/IEC Directives, Part 1. In particular, the different approval criteria needed for the different types of ISO document should be noted. This document was drafted in accordance with the editorial rules of the ISO/IEC Directives, Part 2 (see www.iso.org/directives).

ISO draws attention to the possibility that the implementation of this document may involve the use of (a) patent(s). ISO takes no position concerning the evidence, validity or applicability of any claimed patent rights in respect thereof. As of the date of publication of this document, ISO had received notice of (a) patent(s) which may be required to implement this document. However, implementers are cautioned that this may not represent the latest information, which may be obtained from the patent database available at www.iso.org/patents. ISO shall not be held responsible for identifying any or all such patent rights.

Any trade name used in this document is information given for the convenience of users and does not constitute an endorsement.

For an explanation of the voluntary nature of standards, the meaning of ISO specific terms and expressions related to conformity assessment, as well as information about ISO's adherence to the World Trade Organization (WTO) principles in the Technical Barriers to Trade (TBT), see www.iso.org/iso/foreword.html.

This document was prepared by Technical Committee ISO/TC 118, *Compressors and pneumatic tools, machine and equipment, Subcommittee SC 3, Pneumatic tools and machines*, in collaboration with the European Committee for Standardization (CEN) Technical Committee CEN/TC 255, *Hand-held, non-electric power tools - Safety*, in accordance with the Agreement on technical cooperation between ISO and CEN (Vienna Agreement).

This second edition cancels and replaces the first edition (ISO 11148-13:2017) which has been technically revised.

The main changes are as follows:

- Definition of light and heavy-duty tools updated to use mass and length of fasteners determining factor.
- Established 5 s maximum time period for the trigger time-out period.
- Test protocols for trigger timeout period included.
- Adoption of symbol [G.1](#) for tools capable of automatic reversion.

A list of all parts in the ISO 11148 series can be found on the ISO website.

Any feedback or questions on this document should be directed to the user's national standards body. A complete listing of these bodies can be found at www.iso.org/members.html.

ISO/DIS 11148-13:2026(en)

Introduction

This document is a type C standard as stated in ISO 12100:2010.

The machinery concerned and the extent to which hazards, hazardous situations and events are covered are indicated in the Scope.

When provisions of this type C standard are different from those which are stated in type A or B standards, the provisions of this type C standard take precedence over the provisions of other standards, for machine that have been designed and built according to the provisions of this type C standard.

The ISO 11148 series consist of a number of independent parts for individual types of hand-held non-electric power tools.

Certain parts of ISO 11148 cover hand-held non-electric power tools, driven by internal combustion engines powered by gaseous or liquid fuel. In these parts, the safety aspects relating to internal combustion engines are found in a normative annex.

The parts are type C standards and refer to pertinent International Standards of type A and B where such standards are applicable.

The following patent documents are highlighted to provide awareness of proprietary technologies related to the automatic reversion function.

US 10,213,911

US 10,532,453

US 9,662,776

EP 3,263,284

US 10,335,936

EP 2,767,365

US 11,229,996

US 11420312B2

Sample Document

get full document from standards.iteh.ai

Hand-held non-electric power tools — Safety requirements —

Part 13: Fastener driving tools

1 Scope

This document specifies safety requirements for hand-held non-electric power tools intended for installation of a fastener, (hereinafter referred to as “fastener driving tools”) forming a mechanical connection or attachment with the workpiece. This document is applicable to fastener driving tools that are powered by compressed air or combustible gases (which may be ignited by a battery or accumulator) and where the energy is transmitted to an impacted element by an intermediary component that does not leave the device.

NOTE These fastener driving tools are intended to be used by one operator and supported by the operator's hand or hands, with or without a suspension, e.g. a balancer.

This document is applicable to fastener driving tools in which energy is applied to a loaded fastener for the purpose of driving this into a workpiece.

This document deals with all significant hazards, hazardous situations or hazardous events relevant to fastener driving tools for fasteners when they are used as intended and under conditions of misuse which are reasonably foreseeable by the manufacturer, with the exception of the use of power tools in potentially explosive atmospheres.

This document is not applicable to fastener driving tools in which the energy for driving fasteners is drawn from powder-actuated cartridges, hydraulics or from any type of electrical supply.

This document does not deal with special requirements and modifications of hand-held power tools for the purpose of mounting them in a fixture.

This document is not applicable to fastener driving tools or fastener driving tool components which are manufactured before the date of publication of the standard.

NOTE ISO 80079-36 gives requirements for non-electrical equipment for potentially explosive atmospheres.

2 Normative references

The following documents are referred to in the text in such a way that some or all of their content constitutes requirements of this document. For dated references, only the edition cited applies. For undated references, the latest edition of the referenced document (including any amendments) applies.

ISO 3857-3, *Compressors, pneumatic tools and machines — Vocabulary — Part 3: Pneumatic tools and machines*

ISO 3864-2:2016, *Graphical symbols — Safety colours and safety signs — Part 2: Design principles for product safety labels*

ISO 4871, *Acoustics — Declaration and verification of noise emission values of machinery and equipment*

ISO 5391, *Pneumatic tools and machines — Vocabulary*

ISO 7010:2019, *Graphical symbols — Safety colours and safety signs — Registered safety signs*

ISO 28927-13, *Hand-held portable power tools — Test methods for evaluation of vibration emission — Part 13: Fastener driving tools*

ISO/DIS 11148-13:2026(en)

ISO 12100:2010, *Safety of machinery — General principles for design — Risk assessment and risk reduction*

ISO 13732-1:2006, *Ergonomics of the thermal environment — Methods for the assessment of human responses to contact with surfaces — Part 1: Hot surfaces*

ISO 13732-3, *Ergonomics of the thermal environment — Methods for the assessment of human responses to contact with surfaces — Part 3: Cold surfaces*

EN 1005-3, *Safety of machinery — Human physical performance - Part 3: Recommended force limits for machinery operation*

EN 1005-4, *Safety of machinery — Human physical performance - Part 4: Evaluation of working postures and movements in relation to machinery*

EN 12096, *Mechanical vibration — Declaration and verification of vibration emission values*

EN 12549, *Acoustics — Noise test code for fastener driving tools — Engineering method*

EN 15895:2025, *Cartridge operated hand-held tools — Safety requirements — Fixing and hard marking tools*

3 Terms and definitions

For the purposes of this document, the terms and definitions given in ISO 12100:2010, ISO 3857-3 and ISO 5391 and the following apply.

ISO and IEC maintain terminological databases for use in standardization at the following addresses:

- IEC Electropedia: available at <https://www.electropedia.org/>
- ISO Online Browsing Platform: available at <https://www.iso.org/obp>

3.1

hand-held power tool

machine operated by one or two hands and driven by rotary or linear motors powered by compressed air, gaseous or liquid fuel (which may be ignited by a battery or an accumulator) or stored energy (e.g. by a spring) to do mechanical work and so designed that the motor and the mechanism form an assembly that can easily be brought to its place of operation

3.2

fastener

mechanical device used for securing fixings to surfaces, or joining materials together

EXAMPLE nails, staples and pins

3.3

fastener driving tool

hand-held power tool (3.1) in which energy is applied in a linear motion to a loaded *fastener* (3.2) for the purpose of driving the *fastener* (3.2) into defined materials

3.4

pneumatic fastener driving tool

fastener driving tool (3.3), where energy to drive the *fasteners* (3.2) comes from compressed air

3.5

gas fastener driving tool

fastener driving tool (3.3), where energy to drive the *fasteners* (3.2) comes from combustion of gases

3.6

horizontal-down orientation

orientation where the fastener driving tool's *nose* (3.24) is normal to a horizontal work surface and pointed downwards

ISO/DIS 11148-13:2026(en)

3.7

horizontal-up orientation

orientation where the fastener driving tool's *nose* (3.24) is normal to a horizontal work surface and pointed upwards

3.8

vertical orientation

orientation where the fastener driving tool's *nose* (3.24) is normal to a vertical work surface

3.9

production application

high-volume professional application such as pallets, furniture, manufactured housing, upholstery, sheathing and roofing

3.10

coil nailer

fastener driving tool (3.3) that drives *fasteners* (3.2) from a collated coil of nails

Note 1 to entry: The primary purpose of this tool being production applications

3.11

heavy-duty stapler and finish nailer

fastener driving tool (3.3) capable of driving:

- *fasteners* (3.2) with mass $\geq 0,5$ g;
- *fasteners* (3.2) with mass $\geq 0,4$ g and length > 26 mm;
- *fasteners* (3.2) with length > 36 mm

Note 1 to entry: These tools are primarily for production applications.

3.12

light-duty tool

fastener driving tool (3.3) capable of driving:

- *fasteners* (3.2) with mass $< 0,5$ g and length is ≤ 26 mm or;
- *fasteners* (3.2) with mass $< 0,4$ g with length ≤ 36 mm

3.13

pinner

fastener driving tool (3.3) capable of driving *fasteners* (3.2) up to 51 mm in length and a maximum gauge of 23 (0,64 mm) diameter

Note 1 to entry: Larger gauge pinner are available.

3.14

single-blow fastener driving tool

fastener driving tool (3.3) that drives a *fastener* (3.2) with a single stroke of the driving element

3.15

multi-blow tool

fastener driving tool (3.3) that drives a *fastener* (3.2) with more than one stroke of the driving element

3.16

fastener driving tool without workpiece contact

any *fastener driving tool* (3.3) that drives a *fastener* (3.2) and which does not have a *workpiece contact* (3.21)

3.17

collating material

material for joining together single *fasteners* (3.2) in strips or coils with adhesive, paper or plastic tape, plastic strap or wire

ISO/DIS 11148-13:2026(en)

3.18**trigger**

fastener driving tool control, operated manually by an operator

3.19**actuation mode selector**

fastener driving tool control, manually set by the operator, so that the *fastener driving tool* (3.3) operates in a specific actuation mode

3.20**dual activation**

two devices such as *triggers* (3.18), levers or switches that work in conjunction with each other such that both devices require activation to actuate the *fastener driving tool* (3.3)

Note 1 to entry: A sequence of activation may be necessary to actuate the fastener driving tool.

3.21**workpiece contact**

control element or assembly that needs to be activated before a fastening operation can be performed

3.22**extended workpiece contact**

control element or assembly that is extended from the *fastener driving tool* (3.3) and is retracted by pressing on the workpiece, preventing the *fastener driving tool* (3.3) from driving a *fastener* (3.2) when not pressed against the workpiece

3.23**retracted workpiece contact**

workpiece contact (3.21) that is retracted and extends when the *trigger* (3.17) is activated, preventing the *fastener driving tool* (3.3) from driving a *fastener* (3.2) when not pressed against the workpiece

3.24**nose**

area of the *fastener driving tool* (3.3) from which a *fastener* (3.2) is ejected.

3.25**full sequential actuation**

actuation mode which allows single driving operations via the *trigger* (3.18) after the *workpiece contact* (3.21) has been operated and further driving operations are only possible after the *trigger* (3.18) and the *workpiece contact* (3.21) have been returned to the non-driving position

Note 1 to entry: The evaluation of actuation modes is given in 5.2.5.1

3.26**single sequential actuation**

actuation mode which allows single driving operations via the *trigger* (3.18) after the *workpiece contact* (3.21) has been operated and further driving operations are possible via *trigger* (3.18) operation if the *workpiece contact* (3.21) has remained in the operating position

3.27**contact actuation**

actuation mode which allows the *fastener driving tool* (3.3) to operate by operating the *workpiece contact* (3.21) while the *trigger* (3.18) is continually depressed and held

3.28**continual contact actuation**

actuation mode in which the driving operations continue as long as the *trigger* (3.18) and the *workpiece contact* (3.21) remain in their operating positions

ISO/DIS 11148-13:2026(en)

3.29**contact actuation with automatic reversion**

actuation mode capable of *contact actuation* (3.27) or *continual contact actuation* (3.28) and where the tool becomes inoperable if the *trigger* (3.18) is depressed without operation of the *workpiece contact* (3.21) within the manufacturer's stated *trigger time-out period* (3.30)

3.30**trigger time-out period**

for *fastener driving tool* (3.3) with automatic reversion; the duration of time a *trigger* (3.18) can be depressed without operation of the *workpiece contact* (3.21) before the tool becomes inoperable

Note 1 to entry: This duration is no longer than 5 s.

3.31**selective actuation**

actuation system that allows discrete selection of two or more of the following actuation modes; *single sequential actuation* (3.26), *full sequential actuation* (3.25), *contact actuation with automatic reversion* (3.29), *continual contact actuation* (3.28) or *contact actuation* (3.27).

3.32**single actuation**

actuation mode in which the *trigger* (3.18) is operated and released for each driving operation

3.33**continual actuation**

actuation mode in which the driving operations are carried out for as long as the *trigger* (3.18) remains in its operating position

3.34**gas container**

non-refillable container which stores and dispenses, using a release device, combustible gas, compressed or liquefied

Note 1 to entry: See [Figures 1](#) and [2](#).

3.35**metering valve**

mechanical or electro-mechanical mechanism designed to control quantity of the combustible gas provided to the gas tool which can be either fitted directly onto the release device, integrated into the release device or be a part of the *gas fastener driving tool* (3.5)

Note 1 to entry: A typical metering valve is shown in [Figure 1](#).

3.36**adapter**

fitting, typically installed on the *gas container* (3.34) by the user, that allows the *gas container* (3.34) to be connected to the gas tool

Note 1 to entry: A typical adapter is shown in [Figure 2](#).

ISO/DIS 11148-13:2026(en)

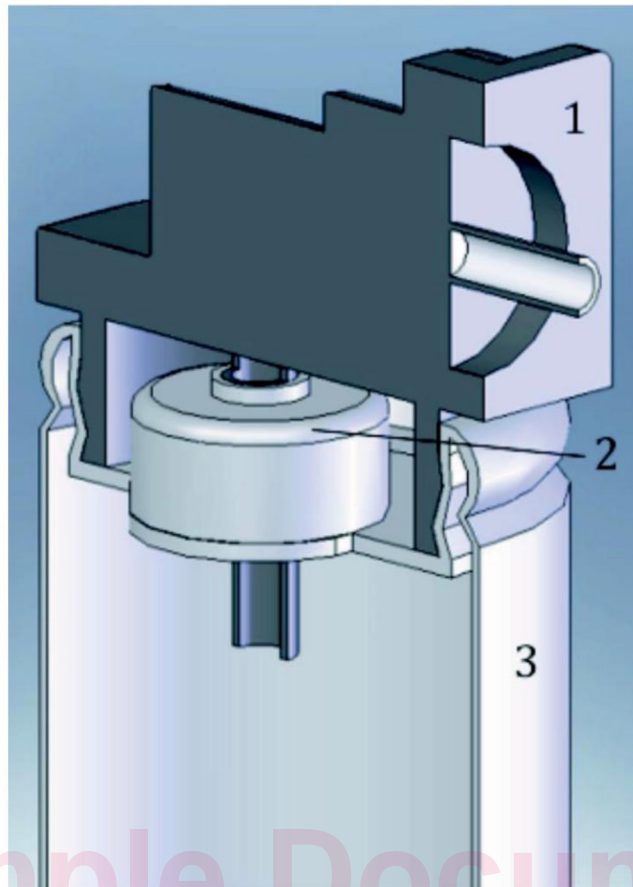

Sample Document

Key

- 1 metering valve
- 2 release device
- 3 gas container

get full document from standards.iteh.ai

Figure 1 — Example of gas container, release device and metering valve

ISO/DIS 11148-13:2026(en)

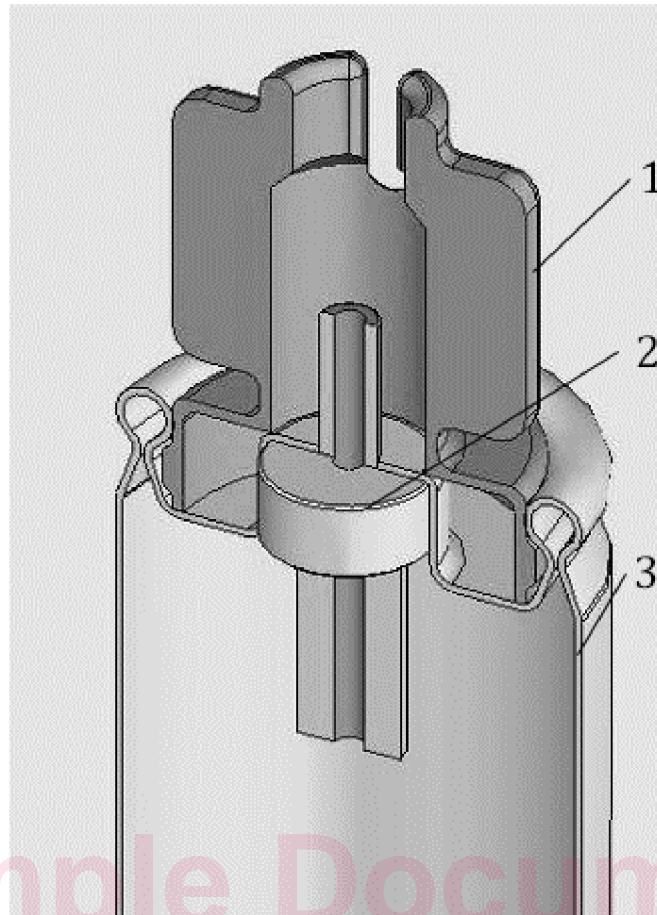
**Key**

- 1 adapter
- 2 release device
- 3 gas container

NOTE In this case, metering valve (not shown) is a part of the tool.

Figure 2 — Example of gas container, adapter and release device

3.37**gas container chamber**

compartment in the *gas fastener driving tool* (3.5) where the *gas container* (3.34) is installed

3.38**battery accumulator**

any source of electrical energy generated by direct conversion of chemical energy and consisting of one or more primary battery cells (non-rechargeable) or consisting of one or more secondary battery cells (rechargeable)

3.39**pressurized section**

chamber(s) of a *pneumatic fastener driving tool* (3.4) that is/are pressurized