

SLOVENSKI STANDARD
oSIST prEN ISO 18119:2026
01-junij-2026

Plinske jeklenke - Plinske jeklenke in velike jeklenke iz celega iz jekla in aluminijevih zlitin - Periodični pregled in preskušanje (ISO/DIS 18119:2026)

Gas cylinders - Seamless steel and seamless aluminium-alloy gas cylinders and tubes - Periodic inspection and testing (ISO/DIS 18119:2026)

Gasflaschen - Nahtlose Gasflaschen und Großflaschen aus Stahl und Aluminiumlegierungen - Wiederkehrende Inspektion und Prüfung (ISO/DIS 18119:2026)

Bouteilles à gaz - Bouteilles et tubes à gaz en acier et en alliages d'aluminium, sans soudure - Contrôles et essais périodiques (ISO/DIS 18119:2026)

Ta slovenski standard je istoveten z: prEN ISO 18119

ICS:

| | | |
|-----------|---------------------------------------|------------------------------------|
| 23.020.35 | Plinske jeklenke | Gas cylinders |
| 77.140.01 | Železni in jekleni izdelki na splošno | Iron and steel products in general |
| 77.150.10 | Aluminijski izdelki | Aluminium products |

oSIST prEN ISO 18119:2026

en,fr,de

Sample Document

get full document from standards.iteh.ai



DRAFT International Standard

ISO/DIS 18119

Gas cylinders — Seamless steel and seamless aluminium-alloy gas cylinders and tubes — Periodic inspection and testing

*Bouteilles à gaz — Bouteilles et tubes à gaz en acier et en alliages
d'aluminium, sans soudure — Contrôles et essais périodiques*

ICS: 23.020.35

ISO/TC 58/SC 4

Secretariat: ANSI

Voting begins on:
2026-04-09

Voting terminates on:
2026-07-02

get full document from standards.iteh.ai

This document is circulated as received from the committee secretariat.

ISO/CEN PARALLEL PROCESSING

Reference number
ISO/DIS 18119:2026(en)

THIS DOCUMENT IS A DRAFT CIRCULATED FOR COMMENTS AND APPROVAL. IT IS THEREFORE SUBJECT TO CHANGE AND MAY NOT BE REFERRED TO AS AN INTERNATIONAL STANDARD UNTIL PUBLISHED AS SUCH.

IN ADDITION TO THEIR EVALUATION AS BEING ACCEPTABLE FOR INDUSTRIAL, TECHNOLOGICAL, COMMERCIAL AND USER PURPOSES, DRAFT INTERNATIONAL STANDARDS MAY ON OCCASION HAVE TO BE CONSIDERED IN THE LIGHT OF THEIR POTENTIAL TO BECOME STANDARDS TO WHICH REFERENCE MAY BE MADE IN NATIONAL REGULATIONS.

RECIPIENTS OF THIS DRAFT ARE INVITED TO SUBMIT, WITH THEIR COMMENTS, NOTIFICATION OF ANY RELEVANT PATENT RIGHTS OF WHICH THEY ARE AWARE AND TO PROVIDE SUPPORTING DOCUMENTATION.

© ISO 2026

Sample Document

get full document from standards.iteh.ai



COPYRIGHT PROTECTED DOCUMENT

© ISO 2026

All rights reserved. Unless otherwise specified, or required in the context of its implementation, no part of this publication may be reproduced or utilized otherwise in any form or by any means, electronic or mechanical, including photocopying, or posting on the internet or an intranet, without prior written permission. Permission can be requested from either ISO at the address below or ISO's member body in the country of the requester.

ISO copyright office
CP 401 • Ch. de Blandonnet 8
CH-1214 Vernier, Geneva
Phone: +41 22 749 01 11
Email: copyright@iso.org
Website: www.iso.org

Published in Switzerland

© ISO 2026 – All rights reserved

ISO/DIS 18119:2026(en)

Contents

| | Page |
|--|-----------|
| Foreword | v |
| Introduction | vi |
| 1 Scope | 1 |
| 2 Normative references | 1 |
| 3 Terms and definitions | 1 |
| 4 Abbreviated terms and symbols | 2 |
| 5 Intervals between periodic inspections and tests | 3 |
| 6 List of procedures for periodic inspections and tests | 3 |
| 7 Identification of cylinder and preparation for inspection and tests | 4 |
| 8 Depressurization and de-valving procedures | 4 |
| 8.1 General..... | 4 |
| 8.2 Cylinders requiring de-valving..... | 5 |
| 8.3 Cylinders not requiring de-valving..... | 5 |
| 8.4 Cylinders requiring external shot blasting..... | 5 |
| 9 External visual inspection | 5 |
| 9.1 Preparation..... | 5 |
| 9.2 Inspection procedure..... | 6 |
| 10 Inspection of cylinder neck | 6 |
| 10.1 Cylinder-to-valve threads..... | 6 |
| 10.2 Other neck surfaces..... | 8 |
| 10.3 Damaged internal neck threads..... | 9 |
| 10.4 Neckring and collar attachment..... | 9 |
| 11 Check of internal condition | 9 |
| 11.1 General..... | 9 |
| 11.2 Internal visual inspection..... | 9 |
| 11.2.1 Preparation..... | 9 |
| 11.2.2 Inspection requirements..... | 10 |
| 11.2.3 Cylinders with footrings..... | 10 |
| 11.2.4 Cylinders with internal coatings..... | 10 |
| 12 Supplementary tests | 11 |
| 12.1 General..... | 11 |
| 12.2 Additional test for seamless aluminium-alloy cylinders possibly subjected to heat damage..... | 11 |
| 12.3 Hammer test on cylinders with footrings..... | 11 |
| 13 Cylinder repairs | 11 |
| 14 Pressure test or UT | 11 |
| 14.1 General..... | 11 |
| 14.2 Proof pressure test..... | 12 |
| 14.2.1 General..... | 12 |
| 14.2.2 Test equipment..... | 12 |
| 14.2.3 Test criteria..... | 13 |
| 14.2.4 Acceptance criteria..... | 13 |
| 14.3 Hydraulic volumetric expansion test..... | 13 |
| 14.4 UT..... | 14 |
| 14.4.1 General..... | 14 |
| 14.4.2 Requirements..... | 14 |
| 14.4.3 Calibration..... | 18 |
| 14.4.4 Performing the examination..... | 23 |
| 14.4.5 Interpretation of results..... | 24 |

ISO/DIS 18119:2026(en)

| | | |
|---------------------|--|-----------|
| 14.4.6 | Records | 25 |
| 15 | Inspection of valve and other accessories | 26 |
| 16 | Replacement of cylinder parts | 26 |
| 17 | Final operations | 26 |
| 17.1 | Drying, cleaning and painting | 26 |
| 17.1.1 | Drying and cleaning | 26 |
| 17.1.2 | Painting and coating | 26 |
| 17.2 | Re-valving of the cylinder | 27 |
| 17.3 | Check of cylinder tare | 27 |
| 17.4 | Retest marking | 28 |
| 17.4.1 | General | 28 |
| 17.4.2 | Stamping | 28 |
| 17.5 | Reference to next periodic inspection and test date | 28 |
| 17.6 | Identification of contents | 28 |
| 17.7 | Records | 28 |
| 18 | Rejection and rendering cylinder unserviceable | 29 |
| 18.1 | General | 29 |
| 18.2 | Cylinders with a valve attached | 29 |
| 18.3 | Cylinders with no valves attached | 29 |
| Annex A | (informative) Periodic inspection and test periods | 30 |
| Annex B | (normative) Description, evaluation of defects and conditions for rejection of seamless steel and seamless aluminium-alloy cylinders at the time of periodic inspection | 31 |
| Annex C | (informative) List of gases corrosive to steel cylinder material | 41 |
| Annex D | (informative) Volumetric expansion testing of cylinders | 42 |
| Annex E | (informative) Test date rings for cylinders | 50 |
| Annex F | (informative) Cleaning of seamless aluminium-alloy cylinders | 52 |
| Bibliography | | 53 |

ISO/DIS 18119:2026(en)

Foreword

ISO (the International Organization for Standardization) is a worldwide federation of national standards bodies (ISO member bodies). The work of preparing International Standards is normally carried out through ISO technical committees. Each member body interested in a subject for which a technical committee has been established has the right to be represented on that committee. International organizations, governmental and non-governmental, in liaison with ISO, also take part in the work. ISO collaborates closely with the International Electrotechnical Commission (IEC) on all matters of electrotechnical standardization.

The procedures used to develop this document and those intended for its further maintenance are described in the ISO/IEC Directives, Part 1. In particular, the different approval criteria needed for the different types of ISO documents should be noted. This document was drafted in accordance with the editorial rules of the ISO/IEC Directives, Part 2 (see www.iso.org/directives).

ISO draws attention to the possibility that the implementation of this document may involve the use of (a) patent(s). ISO takes no position concerning the evidence, validity or applicability of any claimed patent rights in respect thereof. As of the date of publication of this document, ISO [had/had not] received notice of (a) patent(s) which may be required to implement this document. However, implementers are cautioned that this may not represent the latest information, which may be obtained from the patent database available at www.iso.org/patents. ISO shall not be held responsible for identifying any or all such patent rights.

Any trade name used in this document is information given for the convenience of users and does not constitute an endorsement.

For an explanation of the voluntary nature of standards, the meaning of ISO specific terms and expressions related to conformity assessment, as well as information about ISO's adherence to the World Trade Organization (WTO) principles in the Technical Barriers to Trade (TBT), see www.iso.org/iso/foreword.html.

This document was prepared by ISO/TC 58, *Gas cylinders*, Subcommittee SC 4, *Operational requirements for gas cylinders*.

This second edition cancels and replaces ISO 18119:2018, which have been technically revised. It also incorporates the ISO 18119:2018/Amd 1:2021 and ISO 18119:2019/Amd 2: 2024.

The main changes are:

- update of definitions;
- technical review of [8.4](#) and [10.1](#);
- a review and improvement of [14.4.3](#).

Any feedback or questions on this document should be directed to the user's national standards body. A complete listing of these bodies can be found at www.iso.org/members.html.

ISO/DIS 18119:2026(en)

Introduction

This document provides information and procedures for the periodic inspection and testing of seamless steel and seamless aluminium-alloy cylinders and the condition of the test equipment. The principal aim of periodic inspection and testing is that at the completion of the test the cylinders have been requalified and are suitable to be reintroduced into service for a further period of time.

This document requires that well-trained and competent personnel undertake the work as described in this document, who consult the cylinder's manufacturer if there are doubts about aspects of the document, so that the cylinder manufacturer's current recommendations are taken into account.

This document has been written so that it is suitable to be referenced in the UN *Model Regulations*^[23].

This document also gives requirements concerning safety of the personnel, preparation, finishing and maintenance steps of [periodic inspection and testing of gas cylinders]. These requirements can be mandatory under other regulations (e.g. work permits).

Sample Document

get full document from standards.iteh.ai

Gas cylinders — Seamless steel and seamless aluminium-alloy gas cylinders and tubes — Periodic inspection and testing

CAUTION — Some of the tests specified in this document involve the use of processes that could lead to a hazardous situation.

1 Scope

This document specifies the requirements for periodic inspection and testing to verify the integrity of cylinders and tubes to be re-introduced into service for a further period of time.

This document is applicable to seamless steel and seamless aluminium-alloy transportable gas cylinders intended for compressed and liquefied gases under pressure, of water capacity from 0,5 l up to 150 l and to seamless steel and seamless aluminium-alloy transportable gas tubes intended for compressed and liquefied gases under pressure, of water capacity greater than 150 l. It also applies, as far as practical, to cylinders of less than 0,5 l water capacity.

This document does not apply to the periodic inspection and maintenance of acetylene cylinders or to the periodic inspection and testing of composite cylinders.

NOTE Unless noted by exception, the use of the word “cylinder” in this document refers to both cylinders and tubes.

2 Normative references

The following documents are referred to in the text in such a way that some or all of their content constitutes requirements of this document. For dated references, only the edition cited applies. For undated references, the latest edition of the referenced document (including any amendments) applies.

ISO 6506-1, *Metallic materials — Brinell hardness test — Part 1: Test method*

ISO 7866, *Gas cylinders — Refillable seamless aluminium alloy gas cylinders — Design, construction and testing*

ISO 9712, *Non-destructive testing — Qualification and certification of NDT personnel*

ISO 9809-1, *Gas cylinders — Design, construction and testing of refillable seamless steel gas cylinders and tubes — Part 1: Quenched and tempered steel cylinders and tubes with tensile strength less than 1 100 MPa*

ISO 10286, *Gas cylinders — Vocabulary*

ISO 11621, *Gas cylinders — Procedures for change of gas service*

ISO 13769, *Gas cylinders — Stamp marking*

ISO 22434, *Gas cylinders — Inspection and maintenance of valves*

ISO 25760, *Gas cylinders — Operational procedures for the safe removal of valves from gas cylinders*

ASNT SNT-TC-1A, *Personnel qualification and certification in non-destructive testing*

3 Terms and definitions

For the purposes of this document, the terms and definitions given in ISO 10286 and the following apply.

ISO and IEC maintain terminological databases for use in standardization at the following addresses:

ISO/DIS 18119:2026(en)

- IEC Electropedia: available at <https://www.electropedia.org/>
- ISO Online browsing platform: available at <https://www.iso.org/obp>

3.1

competent authority

any body or authority designated or otherwise recognized as such for any purpose in each country by its government

Note 1 to entry: The term “competent body” is not to be used. UN Model recommendations only use “competent authority” and “inspection body”.

[SOURCE: ISO 10286:2025, 3.4.15]

3.2

effective beam width

dimension(s) of the ultrasonic beam in the scan plane

3.3

liquefied gas

gas, which, when packaged for transport, is partially liquid at temperatures above -50 °C

Note 1 to entry: A distinction is made between

- a) high pressure liquefied gas: a gas with a critical temperature between -50 °C and 65 °C , and
- b) low pressure liquefied gas: a gas with a critical temperature above 65 °C .

[SOURCE: ISO 10286:2025, 3.5.4, 3.5.5 and 3.5.6]

3.4

minimum design wall thickness

minimum wall thickness as specified in the design standard or technical code

3.5

rejected cylinder

cylinder not fit for service

3.6

stove

treat by heating in a stove or an oven in order to apply a desired surface coating

4 Abbreviated terms and symbols

| | |
|----------|---|
| FBH | flat bottom hole |
| PE | permanent expansion |
| SBT | sidewall-to-base transition region |
| UT | ultrasonic testing |
| <i>C</i> | compressibility (expressed in m^2/N or Pa^{-1}) |
| <i>D</i> | depth of notch in ultrasonic test sample (expressed in mm) |
| <i>K</i> | factor for individual temperature (listed in Table C.1) |
| <i>L</i> | length of notch in ultrasonic test sample (expressed in mm) |
| <i>P</i> | pressure (expressed in bar) |

ISO/DIS 18119:2026(en)

| | |
|----------|---|
| V | cylinder water capacity (expressed in l) |
| W | width of notch in ultrasonic test sample (expressed in mm) |
| X | flaw length (expressed in mm) |
| Y | flaw depth ratio |
| t_{mc} | minimum measured wall thickness of the calibration specimen (expressed in mm) |
| t_m | minimum design wall thickness (expressed in mm) |
| a/t | flaw depth ratio (in per cent) |

5 Intervals between periodic inspections and tests

A cylinder shall be due for periodic inspection and testing on its first receipt by a filler following the expiry of the established interval or, in the absence of regulations, in accordance with the UN *Model Regulations*. [23] [Annex A](#) lists the intervals for period inspection and testing as outlined in the 19th revised edition of the UN *Model Regulations*. The expiry date is based on the last test date shown on the cylinder. Other means of indicating the expiry date may be used.

Provided the cylinder has not been subjected to abusive and abnormal conditions such as being involved in an accident, heat exposure or other severe conditions that would render it unsafe, there is no requirement for the user to return a cylinder before the contents have been used even though the periodic inspection and testing interval has lapsed. However, cylinders, particularly those containing toxic gases, should be retested within a period not exceeding twice the time interval.

Seamless steel or seamless aluminium-alloy cylinders used for self-contained breathing apparatus or self-contained underwater breathing apparatus that are not covered by transport regulations may be submitted for inspection within the interval shown in [Table A.1](#).

get full document from standards.iteh.ai

6 List of procedures for periodic inspections and tests

Assessment of conformity to this document shall be carried out in accordance with the applicable regulations of the countries of use.

Tests and examinations performed to demonstrate compliance shall be conducted using instruments calibrated before being put into service and thereafter according to an established programme.

Each cylinder shall be submitted to periodic inspections and tests. The following procedures, when applicable, form the requirements for such inspections and tests and are explained more fully in subsequent clauses:

- identification of cylinder and preparation for inspection and tests (see [Clause 7](#));
- depressurization and de-valving procedures (see [Clause 8](#));
- external visual inspection (see [Clause 9](#));
- inspection of cylinder neck (see [Clause 10](#));
- check of internal condition (see [Clause 11](#));
- supplementary tests (see [Clause 12](#));
- cylinder repairs (see [Clause 13](#));
- pressure test or UT (see [Clause 14](#));
- inspection of valve and other accessories (see [Clause 15](#));

ISO/DIS 18119:2026(en)

- j) replacement of cylinder parts (see [Clause 16](#));
- k) final operations (see [Clause 17](#));
- l) rejection and rendering cylinder unserviceable (see [Clause 18](#)).

These procedures should be performed in the sequence listed in order to improve the safety of the operation and to detect potential harmful damage. In particular, the external visual inspection (see [Clause 9](#)) shall be carried out before the internal visual inspection (when required) (see [Clause 11](#)), the pressure test, or UT (see [Clause 14](#)).

When a cylinder passes the above listed procedures but the condition of the cylinder remains in doubt, additional, supplementary tests shall be performed to confirm its suitability for continued service (see [Clause 12](#)) or the cylinder shall be rendered unserviceable in accordance with [Clause 18](#).

Depending on the reason for rejection, some cylinders may be recovered in accordance with [Annex B](#).

Mechanical properties of seamless steel and seamless aluminium-alloy cylinders can be affected by heat exposure. Therefore, the maximum temperature for any operation shall be limited in accordance with the manufacturer's recommendation (for seamless aluminium-alloy cylinders, see [17.1.2.3](#)).

Cylinders that fail an inspection or test and cannot be recovered shall be rendered unserviceable in accordance with [Clause 18](#).

The eyesight acuity of operators is critical and should be checked as described in ISO 9712 or ASNT SNT-TC-1A.

7 Identification of cylinder and preparation for inspection and tests

The labelling and permanent markings on the cylinder shall be checked and the information recorded before carrying out any further work. When a toxic, flammable or pyrophoric gas is involved, the owner or the individual presenting the cylinder for retest shall inform the testing facility accordingly. Cylinders with incorrect or illegible markings or unknown gas contents shall be set aside for special handling.

Cylinders intended for a change of gas service shall be treated in accordance with ISO 11621.

For seamless steel cylinders, the following applies in addition:

If the contents are identified as hydrogen or other embrittling gas, only those cylinders manufactured or qualified as hydrogen cylinders shall be used for that service. Check that the cylinder is compatible for hydrogen service, i.e. with respect to the maximum tensile strength and internal surface condition. Seamless steel cylinders marked in accordance with ISO 13769 are stamped "H". Seamless steel cylinders that have not been checked or are not stamped "H" shall not be reintroduced into hydrogen service. Their suitability for their new, intended service shall be evaluated in accordance with ISO 11621.

8 Depressurization and de-valving procedures

8.1 General

Cylinders that require an internal visual inspection shall be depressurized and emptied in a safe, controlled manner and de-valved prior to inspection in accordance with ISO 25760.

Particular attention shall be given to cylinders containing flammable, oxidizing, corrosive or toxic gases to eliminate risks at the internal inspection stage. See [Annex C](#) for a list of gases that are corrosive to steel cylinder material.

Cylinders (other than those with a footing) to be ultrasonically inspected may be examined without being depressurized or having the valve removed.

ISO/DIS 18119:2026(en)

WARNING — The uncontrolled opening and/or removal of valves from cylinders can lead to injury, death and/or property damage.

When ultrasonically testing cylinders that are under pressure, care shall be taken to prevent injuries (e.g. by placing a valve protection device over the valve or by depressurizing the cylinder to 5 bar or less).

8.2 Cylinders requiring de-valving

All cylinders received for testing for which an internal visual inspection is required shall be safely de-valved in accordance with ISO 25760.

Cylinders with a footring shall be de-valved for internal inspection and may be subsequently evaluated by UT.

8.3 Cylinders not requiring de-valving

Cylinders without a footring that are to be evaluated by UT do not require the valves to be removed unless otherwise specified in this document.

8.4 Cylinders requiring external shot blasting

Cylinders containing flammable, corrosive or toxic gases and that require external shot blasting shall be depressurized to 5 bar or less before processing.

9 External visual inspection

9.1 Preparation

If a cylinder's external condition prevents or hinders a proper visual inspection of the surface, then the cylinder shall be prepared before the inspection. If any welded or brazed attachment (e.g. to reattach the neckring) is seen, the cylinder shall be rendered unserviceable in accordance with [Clause 18](#).

The cylinder shall be cleaned and have all loose coatings, labels, corrosion products, tar, oil or other foreign matter removed from its external surface. The external surface of the cylinder shall not at this stage be brushed or blasted until after the external visual inspection has been completed in order to not remove signs of previous damage. .

NOTE [Annex F](#) provides information for the safe cleaning of seamless aluminium-alloy cylinders.

For seamless aluminium-alloy cylinders, when using steel media for blasting, the process parameters shall be carefully selected and controlled to prevent loss of wall thickness. Other media are also acceptable such as walnut shells, dry ice pellets, etc.

The method used to clean the cylinder shall be a validated, controlled process. Care shall be taken at all times to avoid damaging the cylinder taking into account the information provided in [Annex B](#).

If fused nylon, polyethylene or a similar coating has been applied and it is damaged or prevents proper inspection, then this coating shall be removed. If the coating has been removed by the application of heat, then care shall be taken that the applied temperature has not altered the mechanical properties of the cylinder material. The temperatures at which damage occurs are as follows:

- a) For seamless steel cylinders: in no case shall the temperature of the cylinder have exceeded a value of typical 300 °C.
- b) For seamless aluminium-alloy cylinders: in no case shall the temperature of the cylinder have exceeded the limits specified in [17.1.2.3](#).

For both seamless steel and seamless aluminium-alloy cylinders, contact the manufacturer if there is doubt about heat exposure. If the manufacturer cannot be consulted, the cylinder shall be rendered unserviceable in accordance with [Clause 18](#).

ISO/DIS 18119:2026(en)

9.2 Inspection procedure

The external surface of each cylinder shall be inspected for the following in accordance with [Table B.1](#), [Table B.2](#) or [Table B.3](#) as applicable:

- a) dents, cuts, gouges, bulges, cracks, laminations or excessive base wear;
- b) heat damage, torch damage or electric arc burns;
- c) corrosion;
- d) other defects such as illegible, incorrect or unauthorized stamp markings, or unauthorized additions or modifications;
- e) integrity of all permanent attachments;
- f) vertical stability.

Corrosion is likely to occur in the footing area, especially the transition area cylindrical part/footring, and the gap-area convex base/footring. When inspecting cylinders with footrings, extra attention shall be given to these areas.

At this stage, the cylinder shall be visually inspected for signs of corrosion (see [Table B.2](#) for rejection criteria). Attention shall be given to areas where water can be trapped. These areas include the entire base area and the neckring. If corrosion is detected, then the corrosion products and paint shall be removed (e.g. shot blasted), particularly where the corrosion appears on the cylinder shell. If the extent of the corrosion cannot be determined, including doubt about the remaining wall thickness, then the cylinder shall be rejected.

Rejection criteria shall be in accordance with [Annex B](#). Cylinders no longer suitable for future service shall be rendered unserviceable in accordance with [Clause 18](#).

10 Inspection of cylinder neck

10.1 Cylinder-to-valve threads

After the valve is removed, the cylinder-to-valve threads shall be examined to identify the type of thread (e.g. see ISO 11363-2) and to ensure that they are:

- clean and
- free of damage (e.g. burrs, cracks, cross-threading, corrosion, etc.).

Cylinders in toxic or corrosive gas service shall have their threads gauged for wear and ovality using a plug gauge (see [Figures 1](#), [2](#) and [3](#)). The threads of cylinders in other gas services may be verified using appropriate gauges in cases of doubt.

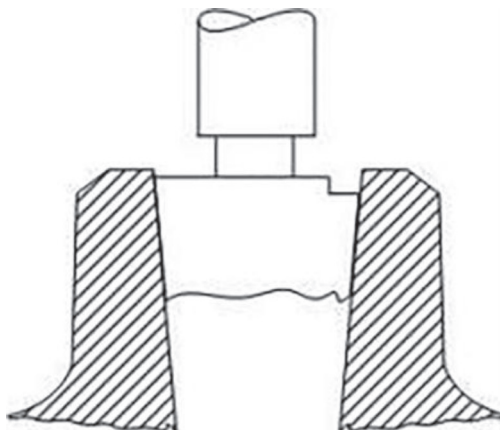

ISO/DIS 18119:2026(en)

Figure 1 — Example of a calibrated upper thread plug gauge (thread failed)

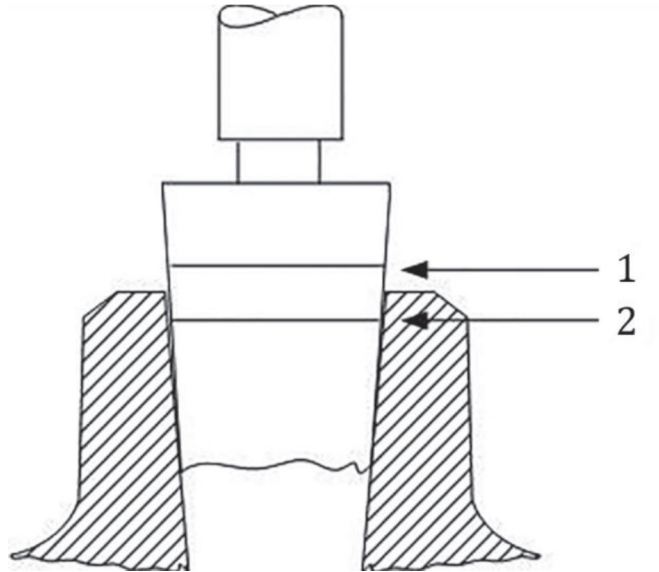

Key

- 1 maximum
- 2 minimum

Figure 2 — Example of a “Go/no-go” plug gauge (thread passed)

Sample Document

get full document from standards.iteh.ai

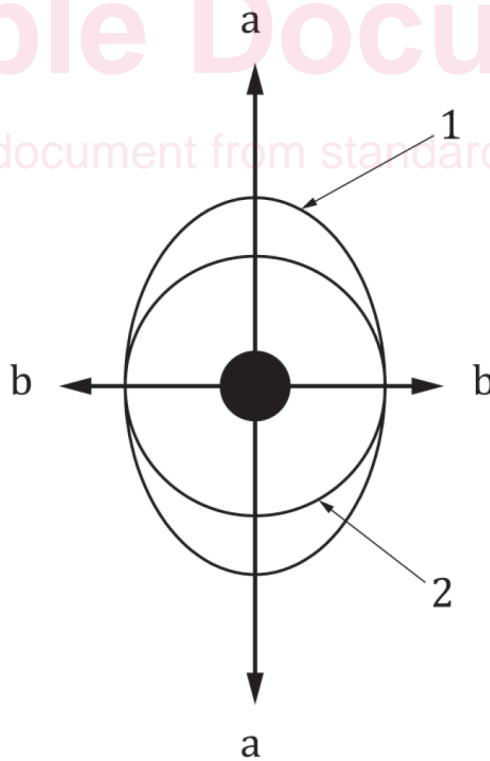

Key

- 1 oval thread in cylinder neck
- 2 plain taper plug gauge
- a Large movement.
- b Small movement.

Figure 3 — Ovality check