Lesnoobdelovalni stroji - Varnost - 4. del: Krožne žage z vertikalno ploščo (ISO/DIS 19085-4:2026)

Woodworking machines - Safety - Part 4: Vertical panel circular sawing machines (ISO/DIS 19085-4:2026)

Holzbearbeitungsmaschinen - Sicherheit - Teil 4: Vertikalplattenkreissägemaschinen (ISO/DIS 19085-4:2026)

Machines à bois - Sécurité - Partie 4: Scies circulaires à panneaux verticales (ISO/DIS 19085-4:2026)

Ta slovenski standard je istoveten z: **prEN ISO 19085-4**

ICS:

13.110	Varnost strojev	Safety of machinery
25.080.60	Strojne žage	Sawing machines
79.120.10	Lesnoobdelovalni stroji	Woodworking machines

oSIST prEN ISO 19085-4:2026 **en**

Sample Document

get full document from standards.iteh.ai



DRAFT International Standard

ISO/DIS 19085-4

Woodworking machines — Safety —

Part 4: Vertical panel circular sawing machines

Machines à bois — Sécurité —

Partie 4: Scies circulaires à panneaux verticales

ICS: 79.120.10; 13.110

ISO/TC 39/SC 4

Secretariat: **UNI**

Voting begins on:
2026-06-01

Voting terminates on:
2026-08-24

This document is circulated as received from the committee secretariat.

ISO/CEN PARALLEL PROCESSING

Reference number
ISO/DIS 19085-4:2026(en)

THIS DOCUMENT IS A DRAFT CIRCULATED FOR COMMENTS AND APPROVAL. IT IS THEREFORE SUBJECT TO CHANGE AND MAY NOT BE REFERRED TO AS AN INTERNATIONAL STANDARD UNTIL PUBLISHED AS SUCH.

IN ADDITION TO THEIR EVALUATION AS BEING ACCEPTABLE FOR INDUSTRIAL, TECHNOLOGICAL, COMMERCIAL AND USER PURPOSES, DRAFT INTERNATIONAL STANDARDS MAY ON OCCASION HAVE TO BE CONSIDERED IN THE LIGHT OF THEIR POTENTIAL TO BECOME STANDARDS TO WHICH REFERENCE MAY BE MADE IN NATIONAL REGULATIONS.

RECIPIENTS OF THIS DRAFT ARE INVITED TO SUBMIT, WITH THEIR COMMENTS, NOTIFICATION OF ANY RELEVANT PATENT RIGHTS OF WHICH THEY ARE AWARE AND TO PROVIDE SUPPORTING DOCUMENTATION.

© ISO 2026

Sample Document

get full document from standards.iteh.ai



COPYRIGHT PROTECTED DOCUMENT

© ISO 2026

All rights reserved. Unless otherwise specified, or required in the context of its implementation, no part of this publication may be reproduced or utilized otherwise in any form or by any means, electronic or mechanical, including photocopying, or posting on the internet or an intranet, without prior written permission. Permission can be requested from either ISO at the address below or ISO's member body in the country of the requester.

ISO copyright office
CP 401 • Ch. de Blandonnet 8
CH-1214 Vernier, Geneva
Phone: +41 22 749 01 11
Email: copyright@iso.org
Website: www.iso.org

Published in Switzerland

ISO/DIS 19085-4:2026(en)

Contents

	Page
Foreword	v
Introduction	vi
1 Scope	1
2 Normative references	2
3 Terms and definitions	2
4 Safety requirements and measures for controls	6
4.1 Safety and reliability of control systems.....	6
4.2 Control devices.....	6
4.2.1 General.....	6
4.2.2 Hand-held control set.....	6
4.2.3 Reset device.....	6
4.3 Start.....	6
4.3.1 Direct start.....	6
4.3.2 Start via control power-on.....	7
4.4 Safe stops.....	7
4.4.1 Stop function.....	7
4.4.2 Normal stop.....	7
4.4.3 Operational stop.....	8
4.4.4 Emergency stop.....	8
4.5 Braking function of tools.....	8
4.6 Operating modes.....	8
4.7 Tool speed.....	8
4.7.1 Speed changing by shifting the belts on the pulleys.....	8
4.7.2 Speed changing by incremental speed change motor.....	8
4.7.3 Speed control by frequency inverter.....	8
4.8 Failure of any energy supply.....	8
4.9 Manual reset control.....	8
4.10 Standstill detection.....	8
4.11 Machine moving parts speed monitoring.....	9
4.12 Time delay.....	9
4.13 Teleservice.....	9
4.14 Protection against corruption.....	9
5 Safety requirements and protective measures against mechanical hazards	9
5.1 Stability.....	9
5.2 Risk of break-up during operation.....	9
5.3 Tool and tool fixing design.....	9
5.3.1 General.....	9
5.3.2 Spindle locking.....	9
5.3.3 Circular saw blade fixing device.....	10
5.3.4 Flange dimension for circular saw blades.....	10
5.4 Tool brake.....	10
5.5 Safeguards.....	10
5.5.1 Fixed guards.....	10
5.5.2 Interlocking movable guards.....	10
5.5.3 Hold-to-run control.....	10
5.5.4 Two-hand control.....	10
5.5.5 Electro-sensitive protective equipment (ESPE).....	10
5.5.6 Pressure-sensitive protective equipment (PSPE).....	11
5.5.7 Enabling control.....	11
5.6 Prevention of access to hazardous moving parts.....	11
5.6.1 Guarding of tools.....	11
5.6.2 Safeguarding of shearing and crushing zones.....	13
5.6.3 Guarding of the rear side.....	14

ISO/DIS 19085-4:2026(en)

	5.6.4 Guarding of drives.....	14
5.7	Impact hazard.....	14
5.8	Clamping devices.....	14
5.9	Measures against ejection.....	14
	5.9.1 Devices against ejection and choice of class of guards.....	14
	5.9.2 Guards of class A, materials and thickness.....	14
	5.9.3 Guards of class B, materials and thickness.....	15
	5.9.4 Anti-kickback devices.....	15
5.10	Workpiece supports and guides.....	16
	5.10.1 Workpiece support.....	16
	5.10.2 Middle support device.....	17
	5.10.3 Angle cutting device.....	17
6	Safety requirements and protective measures against other hazards.....	17
6.1	Fire.....	17
6.2	Noise.....	17
	6.2.1 Noise reduction at the design stage.....	17
	6.2.2 Noise emission measurement and declaration.....	17
6.3	Emission of chips and dust.....	17
6.4	Electricity.....	18
6.5	Ergonomics and handling.....	18
6.6	Lighting.....	19
6.7	Pneumatics.....	19
6.8	Hydraulics.....	19
6.9	Electromagnetic compatibility.....	19
6.10	Laser.....	19
6.11	Static electricity.....	19
6.12	Errors of fitting.....	19
6.13	Isolation.....	19
6.14	Maintenance.....	19
6.15	Risks due to surfaces, edges or angles.....	19
6.16	Relevant but not significant hazards.....	19
7	Information for use.....	19
7.1	Warning devices.....	19
7.2	Marking.....	20
	7.2.1 Marking principles and methods.....	20
	7.2.2 Marking contents.....	20
7.3	Instructions.....	20
	7.3.1 Instructions principles and drafting.....	20
	7.3.2 Instructions handbook contents.....	20
	Annex A (informative) List of significant hazards.....	22
	Annex B (informative) Performance level required.....	24
	Annex C (normative) Brake test.....	26
	Annex D (normative) Impact test for guards.....	27
	Annex E (normative) Noise test code.....	28
	Annex F (normative) Riving knife rigidity tests.....	31
	Annex ZA (informative) ZA - Relationship between this European Standard and the essential requirements of Regulation (EU) 2023/1230 aimed to be covered.....	33

ISO/DIS 19085-4:2026(en)

Foreword

ISO (the International Organization for Standardization) is a worldwide federation of national standards bodies (ISO member bodies). The work of preparing International Standards is normally carried out through ISO technical committees. Each member body interested in a subject for which a technical committee has been established has the right to be represented on that committee. International organizations, governmental and non-governmental, in liaison with ISO, also take part in the work. ISO collaborates closely with the International Electrotechnical Commission (IEC) on all matters of electrotechnical standardization.

The procedures used to develop this document and those intended for its further maintenance are described in the ISO/IEC Directives, Part 1. In particular, the different approval criteria needed for the different types of ISO document should be noted. This document was drafted in accordance with the editorial rules of the ISO/IEC Directives, Part 2 (see www.iso.org/directives).

ISO draws attention to the possibility that the implementation of this document may involve the use of (a) patent(s). ISO takes no position concerning the evidence, validity or applicability of any claimed patent rights in respect thereof. As of the date of publication of this document, ISO had not received notice of (a) patent(s) which may be required to implement this document. However, implementers are cautioned that this may not represent the latest information, which may be obtained from the patent database available at www.iso.org/patents. ISO shall not be held responsible for identifying any or all such patent rights.

Any trade name used in this document is information given for the convenience of users and does not constitute an endorsement.

For an explanation of the voluntary nature of standards, the meaning of ISO specific terms and expressions related to conformity assessment, as well as information about ISO's adherence to the World Trade Organization (WTO) principles in the Technical Barriers to Trade (TBT), see www.iso.org/iso/foreword.html.

This document was prepared by Technical Committee ISO/TC 39, *Machine tools*, Subcommittee SC 4, *Woodworking machines*, in collaboration with the European Committee for Standardization (CEN) Technical Committee CEN/TC 142, *Woodworking machines — Safety*, in accordance with the Agreement on technical cooperation between ISO and CEN (Vienna Agreement).

This document is intended to be used in conjunction with ISO 19085-1:2026.

This third edition cancels and replaces the second edition (ISO 19085-4:2024), which has been technically revised. The main changes are as follows:

- the way of reference from this document to ISO 19085-1:2026 has been simplified, as well as its explanation in Introduction, and aligned to ISO drafting rules;
- the verification methods at the end of each subclause have been deleted, since self-evident;
- [4.2](#), [4.6](#), [7.2](#), [7.3](#) have been rearranged, to follow the new subdivision in ISO 19085-1:2026;
- [4.7.3](#), [5.10](#) have been subdivided, to follow the new subdivision in ISO 19085-1:2026;
- [5.4](#), [5.9](#) have been simplified in structure, for easier reading.

A list of all parts in the ISO 19085 series can be found on the ISO website.

Any feedback or questions on this document should be directed to the user's national standards body. A complete listing of these bodies can be found at www.iso.org/members.html.

ISO/DIS 19085-4:2026(en)

Introduction

The ISO 19085 series provides technical safety requirements for the design and construction of woodworking machinery, as well as for the content of the relevant instruction handbook. It concerns designers, manufacturers, suppliers and importers of the machines specified in the Scope.

This document is a type-C standard as defined in ISO 12100.

This document is of relevance, in particular, for the following stakeholder groups representing the market players with regard to machinery safety:

- machine manufacturers (small, medium and large enterprises);
- health and safety bodies (e.g. regulators, accident prevention organisations, market surveillance).

Others can be affected by the level of machinery safety achieved with the means of the document by the above-mentioned stakeholder groups:

- machine users/employers (small, medium and large enterprises);
- machine users/employees (e.g. trade unions, organizations for people with special needs);
- service providers, for example, for maintenance (small, medium and large enterprises);
- consumers (in case of machinery intended for use by consumers).

The above-mentioned stakeholder groups have been given the possibility to participate in the drafting process of this document.

The machinery concerned and the extent to which hazards, hazardous situations or hazardous events are covered are indicated in the Scope of this document.

When requirements of this type-C standard are different from those which are stated in type-A or type-B standards (as defined in ISO 12100), the requirements of this type-C standard take precedence over the requirements of the other standards for machines that have been designed and built according to the requirements of this type-C standard.

In this document, a subclause can refer to the same subclause of ISO 19085-1:2026 or give specific requirements or both.

Woodworking machines — Safety —

Part 4: Vertical panel circular sawing machines

1 Scope

This document specifies the safety requirements and measures for manually loaded and unloaded vertical panel circular sawing machines (defined in [3.1](#)) capable of continuous production use, with hand feed or integrated feed, hereinafter referred to also as “machines”.

This document deals with all significant hazards, hazardous situations or hazardous events, listed in [Annex A](#), relevant to the machines when used as intended and under conditions of misuse which are reasonably foreseeable, as well as when transported, assembled, adjusted, maintained, dismantling, disabled and scrapped.

The machines are designed for cutting panels consisting of:

- solid wood;
- material with similar physical characteristics to wood (see ISO 19085-1:2021, 3.2);
- composite materials with core consisting, for example, of polyurethane or mineral material laminated with light alloy;
- polymer-matrix composite materials and reinforced thermoplastic/thermoset/elastomeric materials;
- gypsum boards, gypsum bounded fibreboards;
- honeycomb aluminium boards;
- matrix engineered mineral boards, silicate boards;
- aluminium light alloy plates;
- composite boards made from the materials listed above.

This document is also applicable to machines fitted with one or more of the following devices or additional working units, whose hazards have been dealt with:

- an integrated feed device;
- a device for scoring;
- an angle cutting device;
- a middle support device;
- programmable end stops for parallel vertical cuts;
- a device for grooving with a milling tool with a cutting width not exceeding 27 mm;
- a panel pusher;
- a panel lowering device;
- stop devices for workpiece during horizontal cuts.

ISO/DIS 19085-4:2026(en)

This document does not apply to machines

- with pressure beam and saw unit mounted behind the workpiece support,
- where the guide rails on which the saw unit moves vertically are fixed on the machine frame and the horizontal cut can only be made by manually feeding the panel,
- designed to cut in vertical direction only,
- automatically performing two or more cutting cycles in sequence,
- intended for use in potentially explosive atmosphere, and
- manufactured prior to the publication of this document.

2 Normative references

The following documents are referred to in the text in such a way that some or all of their content constitutes requirements of this document. For dated references, only the edition cited applies. For undated references, the latest edition of the referenced document (including any amendments) applies.

ISO 12100:2010, *Safety of machinery — General principles for design — Risk assessment and risk reduction*

ISO 13849-1:2023, *Safety of machinery — Safety-related parts of control systems — Part 1: General principles for design*

ISO 13857:2019, *Safety of machinery — Safety distances to prevent hazard zones being reached by upper and lower limbs*

ISO/DIS 19085-1, *Woodworking machines — Safety — Part 1: Common requirements*

EN 847-1:2017, *Tools for woodworking - Safety requirements - Part 1: Milling tools, circular saw blades*

3 Terms and definitions

For the purposes of this document, the terms and definitions given in ISO 12100:2010, ISO 13849-1:2023, ISO/DIS 19085-1 :2026 and the following apply.

ISO and IEC maintain terminology databases for use in standardization at the following addresses:

- ISO Online browsing platform: available at <https://www.iso.org/obp>
- IEC Electropedia: available at <https://www.electropedia.org/>

3.1

vertical panel circular sawing machine

machine designed for cutting panels, with a nearly vertical workpiece support and a nearly vertical beam mounted parallel to the support and moving horizontally along it, carrying a *saw unit* (3.2) mounted in front of the workpiece support

Note 1 to entry: An example of a vertical panel circular sawing machine is shown in [Figure 1](#). The machine can have a hand feed or an integrated feed .

ISO/DIS 19085-4:2026(en)

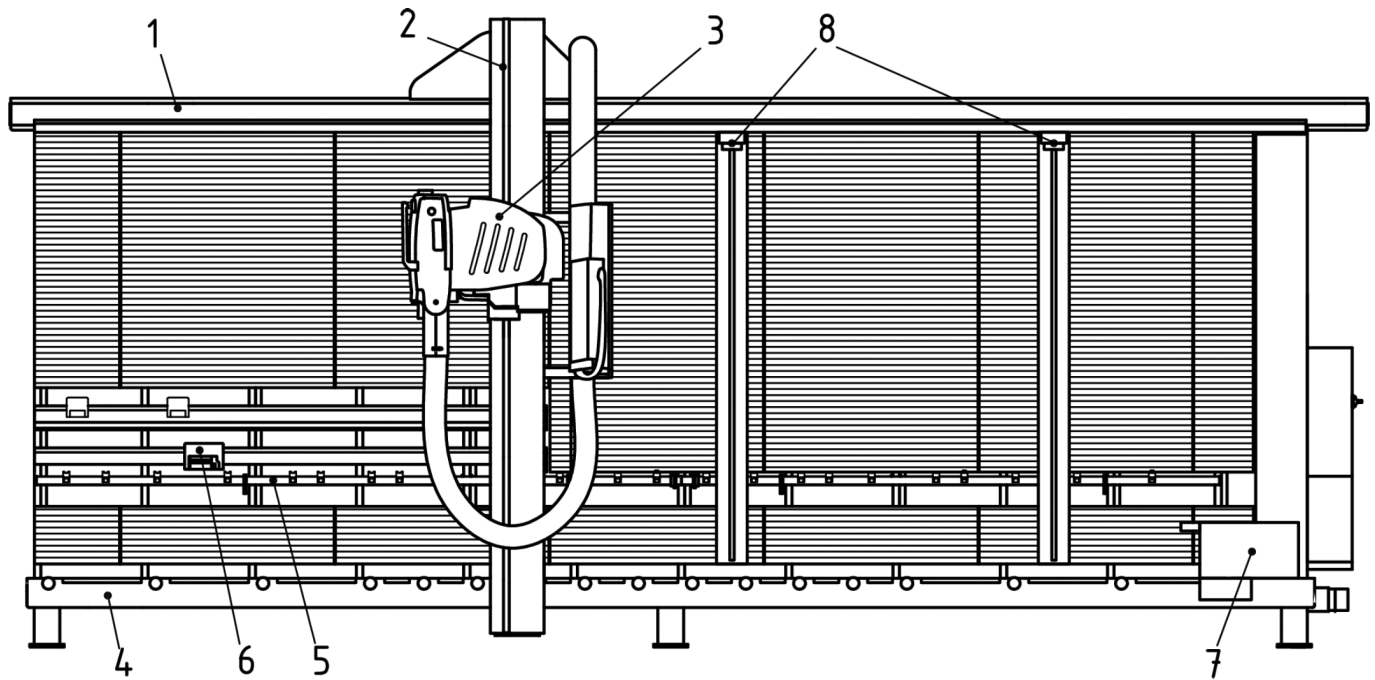

Key

- | | |
|---|--|
| 1 | frame |
| 2 | moving beam |
| 3 | saw unit |
| 4 | base of workpiece support |
| 5 | middle support device |
| 6 | programmable end stop |
| 7 | panel pusher with clamping system |
| 8 | panel lowering device with clamping system |

Figure 1 — Example of a vertical panel circular sawing machine

3.2

saw unit

unit, incorporating and supporting the tools, mounted onto the moving beam

Note 1 to entry: The tools in the saw unit can be saw blades or a milling tool.

Note 2 to entry: The saw unit has two movements in regard to the moving beam: along its whole length for vertical cuts, and perpendicular to it for *infeed* (3.8) and *outfeed* (3.9) movements.

3.3

main saw blade

circular saw blade used to cut the workpiece into smaller pieces

3.4

scoring saw blade

circular saw blade used to pre-cut the workpiece surface, to avoid its damage by the *main saw blade* (3.3)

3.5

rest position

<saw unit> position of the *saw unit* (3.2) most far away from the workpiece support

3.6

pivoting

saw unit rotation, either manual or power driven, between the two perpendicular orientations to perform horizontal or vertical cuts

ISO/DIS 19085-4:2026(en)

3.7

cutting stroke

vertical or horizontal feed from the beginning to the end of a cut

Note 1 to entry: to perform a cutting stroke, either the *saw unit* (3.2) moves along the moving beam, or the moving beam, with the saw unit fixed to it, moves along the workpiece support.

3.8

infeed movement

short movement of the *saw unit* (3.2) perpendicular to the moving beam from the *rest position* (3.5) towards the workpiece support before a *cutting stroke* (3.7)

Note 1 to entry: The infeed movement is power driven on machines with integrated feed and can be power driven or not on machines with manual feed.

3.9

outfeed movement

short movement of the *saw unit* (3.2) perpendicular to the moving beam back to the *rest position* (3.5) after a *cutting stroke* (3.7)

Note 1 to entry: The outfeed movement is power driven on machines with integrated feed and can be power driven or not on machines with manual feed.

3.10

cutting cycle

<machines with integrated feed> single cut operation consisting of a continuous sequence of *infeed movement* (3.8), *cutting stroke* (3.7) and *outfeed movement* (3.9)

Note 1 to entry: A further movement of the saw unit back to its starting position can follow.

3.11

middle support device

device fitted to the workpiece support for supporting a workpiece with small dimensions

3.12

angle cutting device

device fitted to the workpiece support of the machine to position the workpiece in angled orientation

Note 1 to entry: An example of an angle cutting device is shown in [Figure 2](#).